

COD REPORT **CR-96/036.1**



DEPARTMENT OF TRANSPORT

# National Guidelines for Traffic Calming

---

MARCH 1998

<b>TITLE/TITEL NATIONAL GUIDELINES FOR TRAFFIC CALMING</b>			
<b>REPORT NO. VERSLAG NR.</b>	<b>ISBN</b>	<b>DATE SUBMITTED DATUM VOORGELê</b>	<b>REPORT STATUS VERSLAGSTATUS:</b>
CR-96/036.1 (Revision 1)		March 1998	Project Report
<b>RESEARCH NO. / NAVORSINGSNR:</b>			
<b>CARRIED OUT BY: GEDOEN DEUR:</b>		<b>COMMISSIONED BY: OPDRAGGEWER:</b>	
Division of Roads and Transport Technology CSIR P O Box 395 PRETORIA 0001		Director General: Transport Department of Transport Private Bag X193 PRETORIA 0001	
<b>AUTHOR(S): OUTEUR(S):</b>		<b>PUBLISHER: UITDEWER:</b>	
G Schermers M Theyse		Department of Transport Directorate: Research Private Bag X193 PRETORIA 0001	
<b>SINOPSIS:</b>		<b>SYNOPSIS:</b>	
Hierdie dokument dien as 'n omvattende nasionale handleiding vir verkeerskalmering en is opgestel om persone en plaaslike owerhede in die praktyk wat gemoeid is met verkeersingenieurswese, by te staan tydens die implementering van verkeerskalmering. Die verskillende doelwitte van verkeerskalmering word ook toegelig in die dokument en dit bied 'n voorgestelde beleid oor verkeerskalmering vir voornemende gebruikers. Verder word aandag geskenk aan die administratiewe-en bestuursaspekte wat vereis word om doelwitte te verwesenlik tydens implementering en monitering van verkeerskalmering in stedelike gebiede. Aspekte wat ook in hierdie verslag bespreek word behels regsaspekte, aanspreeklikheid en algemene bestuur en onderhoud van verkeerskalmering. Die proses wat nodig is om toepassing van maatreëls te evalueer en te prioritiseer word ook gedefinieer. 'n Metodologie word voorgestel vir die keuse van maatreëls en die geometriese ontwerp van sekere maatreëls word ook in hierdie dokument verskaf.		This document serves as a comprehensive national traffic calming guideline, compiled to assist traffic engineering practitioners and road authorities with the implementation of traffic calming. It outlines the different objectives of traffic calming and provides a policy framework on traffic calming. It also describes the administrative and management procedures required to meet policy objectives in the implementation and monitoring of traffic calming in urban areas. Related legal requirements, liability, and general management and maintenance of calming measures are covered. The processes required in evaluating and prioritising applications for traffic calming measures are defined. A methodology to be used in the selection of calming measures is given and the geometric layouts of typical measures are provided.	
<b>KEY WORDS</b> traffic calming, guideline, implementation, policy framework, monitoring, urban areas. <b>TREFWOORDE</b> calming measures, geometric designs, selection methodology			
<b>COPYRIGHT KOPIEREG</b>		<b>REPORT COST VERSLAGKOSTE</b>	
Department of Transport, except for reference purposes Departement van Vervoer, behalwe vir verwysingsdoeleindes		R	

## DOCUMENT RETRIEVAL PAGE

Report No: CR-96/036.1

Title: National Guidelines for Traffic Calming

Author: G Schermers; M Theyse

Client:  
Department of  
Transport

Client Report No:

Date:  
March 1998Distribution:  
Restricted

Project No: TSG42

OE2: 9456

ISBN:

**Abstract:**

This document serves as a comprehensive national traffic calming guideline, compiled to assist traffic engineering practitioners and road authorities with the implementation of traffic calming. It outlines the different objectives of traffic calming and provides a policy framework on traffic calming. It also describes the administrative and management procedures required to meet policy objectives in the implementation and monitoring of traffic calming in urban areas. Related legal requirements, liability, and general management and maintenance of calming measures are covered. The processes required in evaluating and prioritising applications for traffic calming measures are defined. A methodology to be used in the selection of calming measures is given and the geometric layouts of typical measures are provided.

**Keywords:** traffic calming, guideline, implementation, policy framework, monitoring, urban areas, calming measures, geometric designs, selection methodology

**Proposals for implementation:**

None.

**Related documents (eg software, interim or other reports, working drawings etc):**

None.

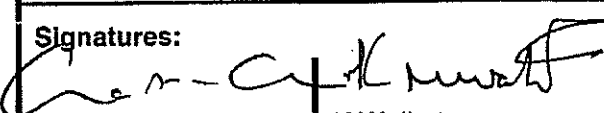
**Signatures:**
  
C Mac Carron  
Language editor

  
K Wolhuter  
Technical Reviewer

  
H Ribbens  
Programme Manager

  
A van der Merwe  
Info Centre

**NOTE:** This document is confidential to Transportek and may only be distributed with the written permission of the Director or his nominee

## **DISCLAIMER**

The views and opinions expressed in this report are those of the authors and do not represent Department of Transport Policy.

The Department of Transport does not accept liability for the consequences of application of the findings expressed in this report.

## **REVIEW STATEMENT**

This report has been reviewed by:

The Steering Committee on National Guidelines for Traffic Calming.

## LIST OF CONTENTS

	<u>Page</u>
<b>SECTION I: INTRODUCTION</b> .....	1-1
<b>CHAPTER 1: INTRODUCTION</b> .....	1-1
1.1 BACKGROUND .....	1-1
1.2 SCOPE OF THE DOCUMENT .....	1-1
1.3 OBJECTIVES OF THE GUIDELINES .....	1-2
1.4 STRUCTURE OF THE DOCUMENT .....	1-2
<b>CHAPTER 2: TRAFFIC CALMING CONCEPTS</b> .....	2-1
2.1 SPEED CALMING .....	2-1
2.2 VOLUME CALMING .....	2-1
 <b>SECTION II: TRAFFIC CALMING MANAGEMENT</b> .....	 3-1
<b>CHAPTER 3: NATIONAL TRAFFIC CALMING POLICY FRAMEWORK</b> .....	3-1
3.1 PURPOSE .....	3-1
3.2 THE NEED FOR TRAFFIC CALMING .....	3-1
3.3 CONSIDERATIONS WITH TRAFFIC CALMING .....	3-1
3.4 SOUTH AFRICAN DEFINITION FOR TRAFFIC CALMING .....	3-2
3.5 GREEN PAPER ON NATIONAL TRANSPORT POLICY .....	3-3
3.6 TRAFFIC CALMING POLICY GOALS .....	3-5
3.7 PRINCIPLES OUTLINING TRAFFIC CALMING POLICY .....	3-6
3.8 TRAFFIC CALMING PLANS .....	3-8
3.9 STRATEGIES TO MEET POLICY GOALS .....	3-8
<b>CHAPTER 4: TRAFFIC CALMING MANAGEMENT</b> .....	4-1
4.1 INTRODUCTION .....	4-1
4.2 FINANCIAL REQUIREMENTS .....	4-1
4.3 PERSONNEL NEEDS .....	4-1
4.4 PUBLIC RELATIONS AND PROMOTION .....	4-3
4.5 LEGAL ASPECTS AND LIABILITY .....	4-4
4.6 IMPLEMENTATION AND MONITORING .....	4-4
4.7 MAINTENANCE .....	4-4
<b>CHAPTER 5: STUDIES INTO TRAFFIC CALMING NEEDS</b> .....	5-1
5.1 INTRODUCTION .....	5-1
5.2 LAND USE AND OTHER CONSIDERATIONS .....	5-1
5.2.1 Land use .....	5-1
5.2.2 Road hierarchy .....	5-3
5.2.3 Layout of the road network .....	5-8
5.3 INFORMATION REQUIREMENTS .....	5-9
5.4 PROBLEM IDENTIFICATION .....	5-10
5.4.1 Scoping studies .....	5-10
5.4.2 Public participation .....	5-14
5.4.3 Detailed studies .....	5-14
5.5 PREPARATION OF SOLUTIONS .....	5-15
5.6 PRIORITISATION .....	5-16
5.7 BEFORE AND AFTER STUDIES .....	5-16
5.8 MONITORING .....	5-17
5.9 PLANNING FRAMEWORK .....	5-17

<b>SECTION III: SELECTION OF APPROPRIATE MEASURES</b> .....	6-1
<b>CHAPTER 6: IDENTIFICATION OF APPROPRIATE MEASURES</b> .....	6-1
6.1 Technical aspects in mixed traffic .....	6-2
6.1.1 Algorithm for selecting measures appropriate to speed reduced zones .....	6-4
6.1.2 Exits .....	6-18
6.2 Selection system for choosing general measures for mixed traffic .....	6-18
6.2.1 Provision for measures impacting at town and regional planning level .....	6-19
<b>CHAPTER 7: APPLICABLE MEASURES FOR SPEED REDUCED ZONES AND ZONES OF MIXED TRAFFIC</b> .....	7-1
7.1 Measure pages .....	7-1
7.1.1 Conditions for applications .....	7-1
7.1.2 Dimensions .....	7-2
7.1.3 Implementation .....	7-2
7.1.4 Supplementary measures .....	7-2
7.1.5 Positive and negative aspects .....	7-3
7.1.6 Remarks .....	7-3
7.2 Measures that impact on town and regional planning (TR1 - TR9) .....	7-3
7.3 Traffic Management measures for mixed traffic .....	7-14
 <b>SECTION IV: ACKNOWLEDGEMENTS AND REFERENCES</b> .....	 8-1
<b>CHAPTER 8: ACKNOWLEDGEMENTS</b> .....	8-1
<b>CHAPTER 9: REFERENCES</b> .....	9-1
 <b>SECTION V: APPENDICES</b> .....	 A-1
<b>APPENDIX A : GEOMETRIC DESIGN CRITERIA</b> .....	A-1
<b>APPENDIX B : OPINION SURVEY QUESTIONNAIRE (EXAMPLE)</b> .....	B-1
<b>APPENDIX C(i) : ORIGIN-DESTINATION SURVEY FORM - VEHICLE REGISTRATION SURVEY</b> .....	C-1
<b>APPENDIX C(ii) : ORIGIN-DESTINATION SURVEY FORM - ROADSIDE INTERVIEW</b> .....	C-2
<b>APPENDIX D: INTERSECTION COUNTS (EXAMPLE SHEET)</b> .....	D-1
<b>APPENDIX E : APPROPRIATE MEASURES FOR PEDESTRIANS AND HANDICAPPED PERSONS</b> .....	E-1
<b>APPENDIX F : CALCULATION OF EAN</b> .....	F-1

## LIST OF TABLES

	<u>Page</u>
Table 5.1 : Characteristics of the Urban Road Hierarchy .....	5-8
Table 5.2 : Warrants for Testing the Feasibility for Detail Investigation .....	5-13

## LIST OF FIGURES

	<u>Page</u>
Figure 5.1: Road Hierarchy .....	5-5
Figure 5.2: Decision Matrix .....	5-18
Figure 6.1: System for selecting reduction measures .....	6-7
Figure 6.2: Selection system for choosing general measures for mixed traffic .....	6-19



---

## **SECTION I: INTRODUCTION**

---

### **CHAPTER 1: INTRODUCTION**

The need for a comprehensive guideline document for traffic calming measures and devices has been expressed by both traffic engineering practitioners and road authorities. This is the first comprehensive document providing standardised geometric layouts for the various devices and would assist planners and engineers with the implementation of traffic calming. It was compiled under the auspices of the Department of Transport and represents the general consensus of the steering committee appointed to assist with the formulation of this first draft and should not be considered final. It would be updated as the results of local research on traffic calming become available.

#### **1.1 BACKGROUND**

This document is based on a combination of local and international practice (Theyse, 1995, AA 1995). The geometric layouts and values provided in the document serve as guidelines. Specific values quoted are intended to help designers evaluate the merits and layout of the project under consideration. However, the final design should also be based on engineering judgement to account for certain variables that are site-specific and which necessitate detailed investigation.

#### **1.2 SCOPE OF THE DOCUMENT**

The scope of this guideline is restricted to traffic calming applications on surfaced, urban roads and which are the responsibility of central, provincial and local governments, with the specific goal of reducing vehicle speeds and/or traffic volumes.

While still only a working draft, it is however, recommended that the guideline framework outlined be adhered to as far as possible. This is to prevent the implementation of non-standard measures. The measures described are extensive and cover the majority of possible applications. In some instances, reference is made to provisions for either pedestrians or handicapped persons. This may seem to duplicate previous work conducted by the DOT (SARB, 1993) although this is not intentional. The inclusion of such measures serve to draw the designers' attention to the specific needs of the different categories of road user when applying traffic calming. At all times, designers must make reference to existing and related local guidelines.

Many of the traffic calming measures presented have not previously been applied in South Africa and extensive before- and -after evaluations should be conducted when implementing these. Monitoring of new measures would be essential in determining the effectiveness of these under local conditions. The limitations, if any, of new implemented designs should be forwarded to the Department of Transport or to the CSIR (for the attention of the Steering Committee on traffic calming).

### 1.3 OBJECTIVES OF THE GUIDELINES

The objectives of these guidelines are :

- to define traffic calming in the South African context;
- to define the role of traffic calming in South Africa;
- to provide an outline of resource requirements and support structures;
- to provide a uniform approach to evaluating applications for traffic calming;
- to standardise traffic calming measures and their application; and
- to provide geometric guidelines for the design of traffic calming measures.

### 1.4 STRUCTURE OF THE DOCUMENT

The document has been structured to broadly cover the requirements for the application of traffic calming.

Chapter 2 serves to describe the different objectives of applying traffic calming. It draws a clear distinction between calming for speed and calming for volume reduction within the context of local, corridor or area wide applications.

Chapter 3 provides a policy framework on traffic calming. It is within this framework that local authorities can tailor specific policy objectives relevant to local requirements.

Chapter 4 describes the administrative and management procedures required to meet general policy objectives in implementing and monitoring traffic calming in urban areas. The chapter also provides an overview of legal requirements, liability, general management and maintenance of calming measures.

Chapter 5 defines the processes required to evaluate applications for the implementation of measures. It provides an overview of the function of traffic calming within the broader context of land use and town planning. The process of problem identification, prioritisation and evaluation is described in detail. This chapter also presents a methodology for the execution of before and after studies.

Chapter 6 provides the user with a methodology for selecting measures. Chapter 7 presents typical geometric layouts of traffic calming measures. Although some measures can be used in conjunction with others, distinction has been drawn between measures to be used at intersections, between intersections and other devices which are not classified as physical measures (passive and psychological). Many of the measures presented have not been widely applied, if at all, in South Africa. They are based on overseas designs and should, therefore, be carefully considered and thoroughly evaluated and monitored. It is also imperative that such evaluations be made known to the DOT and relevant committees in order to maintain uniformity of practice. This would also avoid conflict between the various UTG guidelines.

**CHAPTER 2: TRAFFIC CALMING CONCEPTS**

With traffic calming there is clear distinction between traffic calming to reduce speed and traffic calming to reduce through traffic. This also applies to the measures to be adopted in such schemes.

**2.1 SPEED CALMING**

Traffic calming measures are applied to reduce vehicle speeds on residential roads. This has major impact on local and non-local traffic and serves essentially to improve pedestrian safety. It is also a useful means of reducing vehicle speeds in situations where high speeds create unsafe situations for other motorists requiring access to a particular street (e.g. from driveways with poor sight distance). The objective of speed calming is to reduce the 85th percentile vehicle speed over a length of road or a network of roads (the calmed zone) to an appropriate speed.

Achievement of this objective necessitates a holistic approach and a combination of measures. Essentially the designer should aim to create an awareness among road users that a calmed zone has been entered. This requires extensive planning and careful consideration of the placement of measures.

Measures typically used for speed calming include speed humps, speed cushions, roundabouts, pinch points (chokers), lane closures and chicanes. Speed control measures can be applied both at intersections (e.g. priority reversal) and between intersections.

Generally the designer must aim to achieve the following objectives:

Posted Speed (km/h)		85th Percentile Speed (km/h)	
Before	After	Before	After
60	40 - 60	65+	32 - 48
70	50 - 70	75+	40 - 56
80	60 - 80	85+	48 - 64

**2.2 VOLUME CALMING**

Volume calming refers to situations where local residential areas are exposed to through (non-local) traffic. This is often the result of perceived (sometimes real) capacity constraints on the major road network. Drivers perceive reductions in travel times by selecting alternative routes through residential areas (rat-runs). Volume calming may only be applied in cases where adequate capacity exists on the major road network. Where constraints exist, these should be rectified before measures aimed at volume reduction are implemented. Once again, the road hierarchy and land uses within the study area should be carefully considered and understood. This is to ensure that the access function of roads between the primary road network and non-local traffic generators (such as schools) is not detrimentally affected.

The extent to which non-local traffic has intruded into an area is also an important criterion. During the assessment of areas exposed to through traffic, the study team should determine the number of roads affected, causes of the intrusion of non-local traffic and the severity of the problem. This is important in the sense that the treatment of a single route (where it appears to be the only affected route) may result in the problem recurring on another route within the area. Again it is important that the problem be viewed in a holistic and systems context (i.e. that its impact throughout the area be determined).

Measures to be applied for volume reduction include prohibition and other regulatory signing, closures, one-way mazes, diverters, priority reversals, speed humps etc.

---

## **SECTION II: TRAFFIC CALMING MANAGEMENT**

---

### **CHAPTER 3: NATIONAL TRAFFIC CALMING POLICY FRAMEWORK**

#### **3.1 PURPOSE**

The purpose of this chapter is to outline a policy framework with respect to traffic calming. The proposed policy is formulated in accordance with National Transport Policy imperatives (DoT, 1996).

#### **3.2 THE NEED FOR TRAFFIC CALMING**

A rapidly growing private vehicle population and a decline in public transport patronage have caused many towns and cities in South Africa to experience the effects of congestion. The problem is compounded by a lack of funds for road infrastructure improvement and/or provision. The emphasis is thus on the optimum management of existing infrastructure. However, many problems are still evident, including:

- ineffective road network layouts;
- generous geometric design standards (resulting in high speeds);
- poor driver discipline and education;
- through traffic on residential roads; and
- the role and function of law enforcement.

In an attempt to improve this situation, many local authorities have begun applying traffic management techniques aimed at reducing through traffic volumes and vehicle speeds on residential roads, especially in areas with high pedestrian activity. However, this has also resulted in vastly different approaches to the solution of similar problems, a situation which can only add to the confusion of the driver.

#### **3.3 CONSIDERATIONS WITH TRAFFIC CALMING**

Because the objectives of traffic calming are to reduce vehicle speeds and/or through traffic volumes, traffic calming measures are selected to:

- divert traffic in a natural way;
- reduce travel time and distance where possible;
- keep unwanted traffic out of sensitive areas;
- give priority to pedestrians, cyclists and vulnerable road users;
- regulate traffic in general to serve all road users - pedestrians and motorists; and
- minimise the environmental impact of transportation.

## SECTION II

There are several underlying principles which should be adhered to in the application of traffic calming. These include the following:

- The road hierarchy and function of the various links should be carefully considered and defined before any traffic calming measure is implemented.
- Traffic calming allocates urban space for pedestrians and cyclists by reducing traffic volumes and creating attractive public spaces.
- In residential areas, traffic priorities should be arranged to favour pedestrians, cyclists, public transport users, school children and disabled people first. At all intersections and points where pedestrians need access to buses, the pedestrian should have priority (short-term).
- Pedestrianisation, termination of road projects and pro-public transport policies are not alternatives to traffic calming for they are not equivalents. In countries which made most progress with traffic calming it was proved (Brindle, 1991) that public transport innovations should be seen as part of the wider context of a coherent transport policy.

Public transport and traffic calming share the aim of curbing unnecessary car use. Public transport and traffic calming should complement one another. However, as traffic calming becomes more widespread, problems are increasingly experienced with bus and delivery routes. If journey times on a bus route passing through traffic calmed streets are significantly increased as result of implemented measures, the attractiveness of the service would reduce. When traffic calming is carried out on an area-wide basis, the question of retaining an attractive public transport service becomes particularly important.

There are two basic approaches to the issue of reducing the speeds of relatively small and manoeuvrable cars without causing obstruction to bigger vehicles (such as buses and their passengers). These are that:

- there should be no public transport routes in traffic calmed areas; or
- traffic calming measures which have little or no adverse effect on buses (examples of these would be discussed in Chapters 6 and 7) should be implemented.

Within these two approaches, which are not mutually exclusive, there are many options to ensure compatibility between public and traffic-calmed private transport.

### 3.4 SOUTH AFRICAN DEFINITION FOR TRAFFIC CALMING

There are basically two approaches to traffic calming, namely segregation of vulnerable road users from motor vehicles (devices in roadway) and integration of road users on shared surfaces (e.g. Dutch Woonerf concept). Although in the context of this document it would appear that the focus is on segregation, this is not the intention. The designer should use whatever approach is appropriate in order to meet the objectives encapsulated in the definition of traffic calming.

## SECTION II

The definition that has been accepted for traffic calming in South Africa reads as follows:

*Traffic calming has the objective of moderating traffic behaviour through physical and legislative measures aimed at the reduction of :*

- i) vehicle speeds and/or*
- ii) traffic volumes*

*in order to improve traffic safety and quality of life in the built environment but with due regard to mobility and accessibility so as to ensure a balance between the environment and traffic.*

The above definition differentiates between the method (reduction of speeds/volumes) and the criterion or measure (safety, environment etc.) since traffic calming seeks to treat the cause and not the effect.

### 3.5 GREEN PAPER ON NATIONAL TRANSPORT POLICY

Following the promulgation of the RDP white paper (Government Gazette, 1994), which encapsulates many of the broader objectives of the ANC version of the RDP, significant progress has been made with the formulation of the Green Paper on National Transport Policy.

The Green Paper on National Transport Policy (DOT March 1996) sets clear policy initiatives for four separate transport elements, namely:

- Land passenger transport;
- Land freight transport;
- Air transport; and
- Maritime transport.

It also identifies the need to formulate a policy for Road Traffic (Management and control) and transport infrastructure, both of which would impact on the formulation of policy goals for traffic calming. Road traffic is seen as a focus area of transport policy, with the following mission:

“To ensure an acceptable level of quality in road traffic, with the emphasis on road safety, on the South African Road and street network”.

The strategic objectives aim to:

- improve road safety;
- protect the expensive capital investment in the road system;
- enhance traffic discipline; and
- enhance the administrative and economic order in the field of road traffic and transportation.

## SECTION II

Five policy areas have been identified as the key areas in traffic management. These are:

- funding of road traffic management;
- road traffic control;
- adjudication of traffic offences;
- improvement of road user knowledge, skills and attitudes; and
- road traffic administration and information systems.

Of specific relevance to traffic calming is the role of law enforcement and public understanding and awareness. In support of these broad policy areas, recommendations were developed to address secondary policy priority areas. These include:

- ensuring that road traffic quality should be an important theme, with emphasis on road safety and during all phases of road infrastructure provision;
- integration of transport, road safety and land use planning;
- utilisation of road hierarchy strategies in traffic safety management; and
- design standards;
- facilities of public transport, pedestrians and bicycles;
- development of guidelines (as a joint effort by all three levels of government).

The Green Paper further identifies the following strategic policy objectives for transport infrastructure:

- establishment of sound intermodal coordination structures;
- maintenance and development of the transportation infrastructure system, and prioritisation of its development in terms of sustainable economic and development needs;
- fostering of a sound financial base for transportation infrastructure;
- aiding the promotion of a strong, diverse, efficient and competitive transportation industry within the limits of sustainable transport infrastructure;
- promotion of environmental protection and resource conservation;
- enhancement of the competitiveness of South African industry and the quality of life of its citizens by providing protection to consumers, safety and security and by meeting accessibility, reliability and mobility needs through the provision of transport infrastructure to serve the purpose; and
- advancement of human resource development in the provision of transportation.

Underlying these objectives are specific recommendations addressing numerous critical issues that are relevant to traffic calming. These include that:

- the DOT would assume a coordinating role for transport infrastructure;
- strategies for long term and integrated planning consistent with the country's needs should be developed;
- infrastructure funding should, as far as possible, equal competitive opportunity among transport modes;
- measures to ensure that infrastructure itself is environmentally acceptable and that provision be made for Environmental Impact Assessments (EIA);



## SECTION II

- performance indicators be developed for different types of infrastructure and LOS to measure the extent to which quality of life issues are being met in infrastructure provision; and
- clear guidelines on acceptable, equitable and efficient public involvement processes should be established.

## 3.6 TRAFFIC CALMING POLICY GOALS

In view of the broader transport policy goals (DOT 1996), the following policy objectives are proposed to address the growing transportation and road safety problems in residential areas :

- inclusion of traffic calming as part of an overall transport strategy;
- accommodation of traffic at the correct level of the road hierarchy;
- improvement of the modal share of public transport, reduction of city-wide accident levels and reducing traffic volumes as a broader approach to traffic management at city level;
- introduction of education programmes to increase traffic calming awareness amongst all people at all levels;
- provision of communication channels for the public to participate in the "calming" process;
- circumspection in the application of traffic calming, especially with respect to the function of the road network;
- enhancement of the efficiency of the road network without detrimentally affecting costs;
- minimization of the extent of pollution, environmental and health damage caused by motorised vehicles;
- creation of more open space for human activities;
- protection of residential areas and their residents from unwanted through traffic and its associated dangers;
- encouragement of social and economic activities in city centres;
- moderation of extraneous traffic behaviour without positively excluding traffic;
- promotion of road safety; and
- improvement of traffic flow and a reduction in travel time.

The above goals should form the basis for the setting of goals during policy formulation at the local authority level as needs would differ from local authority to local authority, policy goals should be more specific in addressing local needs. However, the broad goals outlined above should form the basis around which such goals are developed.

## SECTION II

## 3.7 PRINCIPLES OUTLINING TRAFFIC CALMING POLICY

In a national policy on traffic calming, there are three principles which should be endorsed, namely:

- **The apportionment of accountability**

- Personal

Both traffic accidents and personal security are associated with personal costs. People have become insensitive to the road accident rate in the RSA and there is a resistance to fundamental policy options aimed at reducing traffic danger.

Cultural change is essential in the eco-political approach to urban traffic. Any policy aimed at modifying mobility choices would have enormous implications both socially and culturally and should not be considered lightly. It is possible that public attitudes can be changed, provided that intensive public information programmes are introduced and that the public is informed of, and considered in, any change that might influence their its transport needs.

- Community and organisations

Communities and organisations all have a responsibility towards the individual and should become actively involved in traffic calming. Relevant organisations such as professional bodies, civics, trade unions etc., should collaborate with local authorities to address and promote traffic calming. The local authorities should take the initiative and be actively supported by these bodies.

- Government

There is a challenge to the Government and the traffic professionals who serve them. They would have to find a way in which they can make a contribution to real change in cities. They should start by realising that the future of traffic management in local streets and the resolution of the urban traffic dilemma may well lie on the same path: management of cities, transport systems and travel demand to create an environment in which social attitudes to travel can change.

The RDP (ANC,1994) is clear on its priorities, which are to meet the basic needs of people, of which transport, a clean and healthy environment and social welfare are but a few. The Government has already committed itself to meet these requirements and has urged that ..."road safety be given the priority it deserves".

The Government strongly supports the concept of a "non-competitive, publicly owned transport system". It is obvious that this objective cannot be achieved overnight. Traffic calming could serve as an alternative to roads that are over-congested as a result of privately owned vehicles. The frustration that many people experience is intolerable, but there is no immediate alternative except the gradual implementation of traffic calming measures, together with a strong modal shift to High Occupancy Vehicles (HOV) and public transport.

## SECTION II

- **The establishment of methods and procedures to achieve policy objectives**  
Policies by themselves would not achieve the desired results unless specific strategies, addressing goals and objectives, are formulated and put into place. The implementation of the strategies would ensure that policy objectives are continually revised and that this policy becomes a way of life.
- **The apportionment of responsibilities and functions**  
Traffic calming is a matter of local importance and the Government subscribes to the principle of devolving functional responsibility wherever possible, provided that the local authority can meet the requirements to effectively perform these functions. The final responsibility for traffic calming thus lies with the local authority.

Various management functions have to be carried out at the different levels of government. At central government level, the Minister of Transport and the DOT are responsible for:

- policy formulation;
- monitoring;
- legislation;
- funding;
- research;
- co-ordination;
- execution of functions; and
- international co-operation.

The Government should incorporate all matters regarding traffic calming into its Transport Policy. The Policy should further provide that legislation should be flexible enough to accommodate traffic calming and specific measures and should be formulated in such a way as to avoid ambiguous interpretation.

At provincial and/or regional level, executive functions, particularly with respect to matters of regional significance, are carried out.

Subject to the national policy on traffic calming, Provincial Governments and metropolitan authorities would also make substantial contributions to traffic calming, especially when traffic calming is extended to corridor and city-wide levels. A major function of metropolitan authorities is to ensure local uniformity of practice based on the National Guidelines.

There is already a growing realisation among professionals and lay groups who are truly concerned about urban ecology, safety and the environment, that the ultimate solution to local traffic problems lies in changing attitudes towards car usage. Provincial and regional authorities could support local authorities by mounting educational and public relations campaigns to create an awareness for the need to change.

Provincial authorities may also have to consider the passing of enabling legislation directed towards the implementation of traffic calming measures by local authorities.

## SECTION II

At local authority level, functions that have to be carried out include:

- formulation and application of local traffic calming policy;
- promulgation and/or application of regulatory measures;
- drafting of local traffic calming plans (TCP's);
- implementation of TCP's; and
- monitoring the results of implemented traffic calming measures.

These functions are intended to support the creation of a pleasant living and recreational environment, protection of open and natural spaces, with consideration of the needs of the local community.

### 3.8 TRAFFIC CALMING PLANS

Traffic calming plans (TCPs) should form the basis for policy implementation at local authority level. The objective of such plans is, in the first instance, to define the need for traffic calming within the context of short, medium and long term transportation planning and, secondly, to propose measures to meet these needs. TCPs must therefore clearly:-

- describe the problems;
- describe alternative solutions;
- evaluate the consequences of alternative solutions;
- propose traffic calming measures;
- prioritise short to long term implementation plan;
- list financial requirements;
- describe monitoring programmes;
- give details of TCP update strategy; and
- give details of approval procedures.

### 3.9 STRATEGIES TO MEET POLICY GOALS

Traffic calming is an important part of an overall transport strategy and should be viewed as such by all practitioners in the field of traffic engineering and, most of all, by residents and road users. It implies restraint of freedom of movement for private motor vehicles in certain areas and city centres to give priority to public transport, cycling, walking and to improve traffic flow.

Traffic calming is well established in most of the larger local authorities today and is viewed by most as a necessity. However, there are still local authorities that are reluctant to implement any measures because of the lack of explicit official approval of central government and/or the lack of appropriate standards and guidelines. The following need to be carried out in order to reduce uncertainty among practitioners and policy makers about the legality of many of the measures:

- Implementation of standard guidelines for traffic calming for use by all local authorities to ensure uniformity in all towns and cities so as to enhance the understanding and use of traffic calming measures among all road users; and
- Inclusion explicit terminology, signage and implementation of traffic calming in the Road Traffic Act and Regulations.

## SECTION II

To be successful in the implementation of traffic calming measures, it would be necessary to:

- develop traffic calming plans as part of short to long term transportation plans;
- ensure that TCPs are comprehensive and take account of the transportation needs of the area;
- involve the public in areas where new traffic calming schemes may affect their daily routine;
- promote traffic calming and educate the public and road users on its use and benefits;
- use traffic calming for what it is intended (objectives) and not as an overt motive for urban renewal or street improvement;
- apply traffic calming together with other traffic engineering measures to keep costs down eg. Provision of a mini-circle where re-alignment of an intersection needs to be done to improve road safety;
- plan in advance to ensure alternative routes where large schemes may inconvenience motorists;
- use appropriate and adequate signage (DoT 1993) to accompany new traffic calming schemes, especially where damage may occur (speed humps) for which a local authority may be liable or responsible;
- give publicity to areas that proved to be successful;
- monitor all measures so as to be pro-active in terms of possible failure or of the provision of additional information to the public; and
- remove or reconstruct measures that are not working, as, apart from failing to achieve the desired end result, they would also defeat all efforts to promote traffic calming.

## SECTION II

### CHAPTER 4: TRAFFIC CALMING MANAGEMENT

#### 4.1 INTRODUCTION

In this chapter the general administrative and other requirements for the management and implementation of traffic calming are described. It is re-iterated that the compilation of traffic calming policy and the development of Traffic Calming Plans (TCPs) are an integral part of traffic calming management so that these would largely be dictated by the specific requirements of the local authority.

#### 4.2 FINANCIAL REQUIREMENTS

Traffic calming schemes are financed by the local authorities responsible for the capital investment in roads, but traffic calming schemes may be accepted by Regional or Central Government, which would then contribute towards the cost.

Contributions from Central Government could be the result of a competitive bidding process, with the local authorities putting in bids at a certain time of the financial year. The bids should be based on short to long term Traffic Calming Plans (TCPs). The Department of Transport should then consider these bids, announce and produce a list of schemes that qualify for funding. This process could be merit-based, according to the application of funds and the success of implemented schemes in terms of meeting traffic calming policy objectives (i.e. reductions in volumes and accidents). Provincial bodies could institute similar systems.

The decision by Central or Provincial Government to contribute could, for example, be based on environmentally justified schemes. These schemes would make a substantial difference to the range of applications that could be submitted by local authorities, but would not, by themselves, generate further subsidy.

Provision for traffic calming projects, based on TCPs and on the short to long term transportation plans, should be made separately in the budget. Prioritisation and evaluation of implementation schemes should be adjudicated as in the case of other capital investment projects.

The amount to be provided in the budget would depend largely on the size of the local authority and the extent of traffic calming within that local authority.

Costs would obviously be affected by a variety of issues such as local conditions (location of services and statutory works), choice of materials and the method of implementation. It is recommended, in order to reduce costs, that traffic calming measures be implemented in conjunction with reconstruction or maintenance works.

#### 4.3 PERSONNEL NEEDS

For traffic calming to be successfully adopted it is recommended that a multi-disciplinary team of specialists be formed within the local authority's engineering structure. There are two distinct levels at which personnel involved with calming would function, namely at the management and operational (implementation) level.

## SECTION II

From discussions with the major local authorities applying traffic calming it appears that, at their scale of operations, the following human resources are required:

<b>Human Resource Description</b>	<b>Responsibility</b>
Coordinator:	Responsible official, report and liaise with public. Traffic calming policy formulation.
Senior transportation engineer:	Preparation of traffic calming policy. Policy. Strategies for implementation. Funding. Project Management. Approval of designs.
Engineer/Engineering technician:	Before and after data collection (supervision) and analysis. Design. Application of warrants. Implementation schedule. Bill of quantities. Costing of works. Maintenance program.
4-8 Traffic survey enumerators:	Before and after data collection (traffic volumes, accidents, traffic speeds, attitudinal surveys, etc.).
Construction supervisor and labourers:	Construction of measures. Road marking and signing. Lighting. Drainage. Maintenance.

The role of the coordinator and senior engineer is purely at a management level. The engineer, who has a significantly lower management function, and the remaining team operate at the implementation level.

This team is responsible for the preparation of TCP's (planning), investigation, design, implementation and monitoring of measures. It is strongly urged that, in addition to the above personnel, the following disciplines be included and a task team be formed to co-ordinate and manage traffic calming within the municipal jurisdiction :

- Town planner;
- Public relations officer; and
- Traffic officer and/or emergency services staff.

## SECTION II

The time inputs of these people would be limited but would ensure that communication between departments is effectively established. This communication would support the processes of public participation and evaluation of project feasibility.

### 4.4 PUBLIC RELATIONS AND PROMOTION

The implementation of traffic management measures sometimes generates great public resistance. In cases where there are conflicting interests, it may be desirable to take a political decision in defining the boundaries of the affected area before selecting, siting and designing the traffic calming measures to be introduced within the area.

Public participation is an essential component for the successful implementation of traffic calming schemes. The affected public must be involved in the planning, implementation and monitoring stages. No traffic calming scheme should be initiated without a majority consensus from residents who may be affected by the proposed scheme. It is also necessary to conduct opinion surveys after the implementation stage to ensure that the measures are acceptable to both local residents and local road users.

Effective public participation requires prior public information. It should therefore be standard practice to circulate information leaflets to residents and affected persons within the study area. These must aim at informing and educating them about traffic calming in general, measures that are used, and the aim and use of these. Although more expensive, it is preferable to inform all residents within the local authority about measures so as to ensure the widest coverage of educational information.

Promotion of the traffic calming concept should precede investigation for implementation. This also serves to gauge public reaction at a broad level and would provoke requests for implementation or opposition against measures. Promotional material would typically explain the need for traffic calming, thus ensuring that individuals understand that they themselves could be contributing to rat running in other areas. The material should explain the function of the road hierarchy to re-enforce the concept of accommodating traffic at the correct level. Residents would normally accept measures in their own area since it helps keep out through traffic and reduces speeds, but would be resistant to measures applied on other routes on which they travel.

Opinion surveys are a vital part of the public relations exercise and should be conducted within the defined study area during the planning stage. The target group would be residents, road users, office workers, residents associations, NGO's, shop keepers and any other interest group that may be affected by the planned scheme. The easiest and most cost-effective method of measuring opinions is by means of public meetings. A more effective and accurate, although expensive, method is by means of questionnaires completed during roadside or telephonic interviews, or even as a mail survey. The sample should be drawn randomly and at least 10 per cent of the affected population should respond.



## SECTION II

### 4.5 LEGAL ASPECTS AND LIABILITY

The Road Traffic Regulations, promulgated in terms of the Road Traffic Act, 1989, Act 39 of 1989, describe all the road traffic signs which fall into the regulatory, warning and information classifications that are required for the implementation of traffic calming measures.

The South African Road Traffic Signs Manual (DOT, 1993) is currently under revision and would include a chapter on signing for traffic calming. This is likely to be issued in draft format during 1998. Provided local authorities comply with the signing requirements for traffic calming measures, thereby ensuring that road users have adequate warning of such devices, claims of negligence are not likely to be successful. To date, no legal precedent has been set.

### 4.6 IMPLEMENTATION AND MONITORING

It is essential that prior to implementation, the local population and affected road users are notified of the scale and nature of measures to be implemented and how these would affect people during the construction period. Regardless of whether construction is Departmental or by contract, it should be carried out under the supervision of the traffic calming team.

The tasks related to implementation of works include:

- basic planning;
- detail design;
- schedule of quantities;
- costing of works;
- preparation of tender documents or assignment of construction team;
- public notification;
- initiation of works; and
- commissioning.

Monitoring is essential to ensure that the selected measures meet the goals and objectives of the project at hand. The traffic calming team are accountable to the public and therefore should view monitoring in this light. Thorough before and after studies and public participation would ensure that implemented measures can be adapted to meet all the criteria defined during the goal setting process.

### 4.7 MAINTENANCE

Maintenance programmes should be developed by the traffic calming team. It is a known fact that many traffic calming measures are inconspicuous largely as a result of poor maintenance. It is therefore the function of the traffic calming team to develop maintenance procedures and programs for the different devices. These procedures should be based on evaluations (of conspicuity, state of road signs, etc.) carried out as part of the monitoring process.

The traffic calming team should identify and determine the costs of the various elements of the traffic calming maintenance plan. This is essential to allow provision to be made in the council budget for preventative and regular maintenance of traffic calming devices.

## SECTION II

The layout of many traffic calming devices and measures include paint on the road surface. These markings are subjected to greater wear than centre and edge line markings which are less exposed to traffic. Weathered paint is also notoriously slippery when wet. The maintenance of road markings applied as part of traffic calming devices should therefore enjoy particular attention.

Road signs providing advance warning of traffic calming devices should be kept clean, unobstructed by vegetation and be highly conspicuous at all times. The alternative, as suggested above, is to face possible charges of negligence.

The devices themselves may sometimes be hit by passing traffic. In the case of speed humps, the leading edge of the hump is subjected to abnormal impact and can thus ravel or break up completely, becoming a menace to vehicles in general.

Maintenance is a major component of effective traffic calming, given the problems as outlined above. The traffic calming team should thus inspect all devices at regular intervals in association with the local authority or organisation responsible for maintenance to determine the nature and extent of repair work that needs to be done. A good working relationship between the two bodies is essential and should be actively fostered by the traffic calming team.

A useful tool in maintenance programmes would be an inventory of all implemented measures. This inventory should include the date of commissioning, road signs used and specific road markings and paint specification, description of materials (e.g. kerbs, paving, islands etc.), and a maintenance schedule. The inventory should be kept on a computerised data base and the type (nature) of maintenance done recorded together with the date. This would allow the identification of maintenance patterns for the respective measures and therefore provide valuable information to formulate preventative programs.

## SECTION II

## CHAPTER 5: STUDIES INTO TRAFFIC CALMING NEEDS

## 5.1 INTRODUCTION

In this chapter the procedures necessary for evaluating the feasibility of traffic calming implementation are outlined. It is specifically focused on information systems, problem identification, preparation of alternative solutions, evaluation and recommendation of solutions, implementation and monitoring.

To a large extent, the preparation of Traffic Calming Plans (as discussed in Chapter 3) is essential since they will constitute a document in the format of classic systems analysis. The needs analysis forms a major portion of the plan and defines the problem to be addressed.

The criteria to be evaluated in the decision process are:

- the origin of the application;
- the function of the road hierarchy;
- site visits;
- evaluation of warrants to calculate weights;
- establish the need for draft plans;
- public acceptance;
- detail design and costing;
- prioritisation; and
- before and after studies.

These criteria would be discussed in detail in this chapter.

## 5.2 LAND USE AND OTHER CONSIDERATIONS

## 5.2.1 Land use

Land use, land distribution and the intensity of development are the primary influences on transport patterns within an urban area. The travel behaviour of residents and the associated demand for transport facilities are influenced by the social, demographic and land use characteristics of the area. In South Africa there are regulations concerning future land use, permissible floor space on a given area of land as well as parking and loading requirements.

Most urban areas in South Africa have shown trends similar to those of other countries with rapid growth in population and area of urbanisation, increase in commercial and industrial activity, increase in car ownership and a continual decline in CBD patronage.

Urban land uses can be broadly classified into residential, commercial, industrial (including transportation and communication) and other land uses. The last-mentioned include institutional (schools, hospitals, universities, etc.) and public spaces (parks, museums etc.). Between 30 and 50 per cent of land is used for residential purposes, 5 per cent for commercial, 10 per cent for industrial and 10 to 25 per cent for other land uses. It has also been found that roads in urban areas (including road reserves) occupy between 25 and 33 per cent of all developed land.

## SECTION II

Each type of land use has different trip generation and attraction characteristics. It is therefore logical that town planners and road design engineers work closely together during the planning stages of related road infrastructure provision/upgrading and land use development projects. It is also clear that the characteristics of the road network servicing the different land uses would have different functional characteristics and these should be taken into account. The need for mobility decreases as the need for access increases. Consequently, roads providing access (primarily to residential areas) do not need to accommodate high volumes of traffic and can be of a significantly lower order or class than roads primarily providing mobility (e.g. arterials, freeways etc.).

Since different land uses have different trip making characteristics, the planner should ensure that land uses generating or attracting large volumes of traffic (e.g. garages, shopping centres etc.) are not located within residential cells/areas. These should be planned to be situated on the boundaries of such areas and to be serviced by the higher order roads. The layout of residential roads should also be such that extraneous traffic is actively discouraged from intruding, and local traffic discouraged from speeding.

Unfortunately, South Africa has become exposed to traffic intrusion and speeding in residential areas, largely as a result of poor land use planning and/or road layout planning. This has been further aggravated by increasing traffic demand which cannot always be accommodated on roads designated to provide mobility, resulting in rat running. This is by no means unique but reflects the situation in many countries which now experience similar problems. These problems can be managed through effective traffic management and traffic calming appears to be the method most likely to succeed in restoring the environmental quality of life to people.

Traffic calming can be implemented in all land use categories. It is essentially intended for use in residential areas, although measures are often implemented in CBD's, industrial and commercial/retail land uses. Often the need for the implementation of measures in areas other than residential areas arise from high pedestrian activity. However, present and future land use needs careful consideration during planning for traffic calming. The extent of the measures applied depends on the land use and on the overall objective of the implementation scheme. However, in all cases a systems approach should be adopted to ensure that a holistic view to identifying problems and developing solutions is taken. This would ensure that traffic calming measures are not implemented in cases where they are not the ideal solution. Examples of such cases are given below:

- Higher order roads have insufficient capacity to accommodate existing demand. This situation is typical where alternative routes through residential areas are possible, and are therefore used. Application of traffic calming measures to the affected alternative routes would not resolve the problem until additional capacity on the higher order roads is provided.
- Application of calming measures on higher order roads to reduce speeds. This has the result of forcing through traffic onto lower order roads (i.e. moving the problem around). This also occurs if traffic calming measures are implemented on specific lower order roads where parallel alternatives are possible.

## SECTION II

- Implementation of measures without associated reduction in through volumes and/or speeds. This happens when detailed studies are not undertaken to determine travel times through the affected area. After these measures have been implemented, travel times through the affected area are still lower than on the designated higher order route.

## 5.2.2 Road hierarchy

Road networks comprise a hierarchy of roads with different classes and functions. The grading of a road relates to the degree of mobility and/or access for which it is designed (NHB, 1995, SAICE, 1981). These range from inter-city routes (providing mobility) to local streets (providing access). Each road class should only intersect with roads within two gradings of itself. The application of inappropriate standards to the design of urban roads has created the following concerns (Dept. of Community Development - DCD, 1983) regarding the basis of older designs and layouts:

- To facilitate driving speeds, wide roads with high levels of visibility are provided;
- To improve driving convenience, generous dimensions with easy horizontal and vertical alignment are provided;
- Designs are simplified to accommodate fixed pattern layouts and cross-sections; and
- Through traffic is not deflected and all roads give access to detached residential properties.

From these the following problems and design failures may become evident from the residents' point of view:

- Vehicle dominance: Motorised traffic receives preferential treatment over pedestrians and cyclists in areas belonging to these latter groups;
- Speed: Generous road geometry encourages speeding, especially on long road sections;
- Recklessness: Related to speeding, with drivers relaxing their concentration on account of the safe appearance of roads;
- Rat running: Short cuts are encouraged by roads that are wider than needed. This is aggravated when large traffic attractors/generators are sited within residential areas;
- Inadequate provision for pedestrians: Safe pedestrian routes (with crossings on major roads) are lacking at schools, bus stops etc;
- Severance: Insensitively located freeways and main roads cut off residential areas from community centres and facilities;
- Accidents: These often occur on roads with many intersections and where on-street parking obscures vision;

## SECTION II

- Poor functional differentiation: Roads in residential areas are often over-designed in case they may be required to serve as through (main) routes some time in the future; and
- Wasteful land use: Land which could be developed is used for circulation space when road reserves are excessively wide.

In response to these problems, a directive was formulated by the Department of Community Development (1983) which reads:

*Design a circulation system for pedestrians, cyclists and motor vehicles which recognises residents' needs for SECURITY OF PERSON AND PROPERTY, ROAD SAFETY, PRIVACY AND ENVIRONMENTAL QUALITY. It should link the various land uses in the most CONVENIENT way and provide for all engineering services in a manner which is FUNCTIONALLY EFFICIENT and ECONOMICAL in the use of resources.*

Future layouts should be in accordance with the Red Book (National Housing Board, 1995) which clearly differentiates between roadways providing mobility and those providing access to fronting land uses. Residential and urban distributor roads have design elements that result in safe conditions permitting free flow at reasonable speed. Residential access streets can be designed to limit speed and discourage free flow.

Based on the above, it is clear that the problems still exist today, hence the need for traffic calming especially on older roads. However, the function of roads within the hierarchy should be understood if the situation of recurring problems (the same problem occurring at different locations once traffic calming actions are implemented) is to be avoided. Further, it should also be realised that the problems are frequently the result of shortcomings on the designated higher order roads. The following sections are based on guidelines issued by SAICE (1981) the DCD (1983) and the National Housing Board (as amended in 1995).

Urban roads should be functionally classified on the basis of distance and destination of travel. A fundamental understanding of how the functional road hierarchy should operate in terms of traffic management, and relation of different land use activities to traffic movement generated, are essential to both planning and engineering.

The function of the urban road network is to distribute traffic between the different land use activities. In an ideal urban network the road hierarchy has three primary categories, namely:

- i) Local roads (within neighbourhoods);
- ii) Local and district distributors (routes between neighbourhoods, within communities and routes between communities and within urban districts); and
- iii) Primary distributors (inter-district routes for city-wide travel).

## SECTION II

In all cases the road geometry and reserve should reflect the traffic demand. The functional classes of roads are illustrated (Figure 5.1) and described in more detail (NHB, DCD, and SAICE) in the following sections.

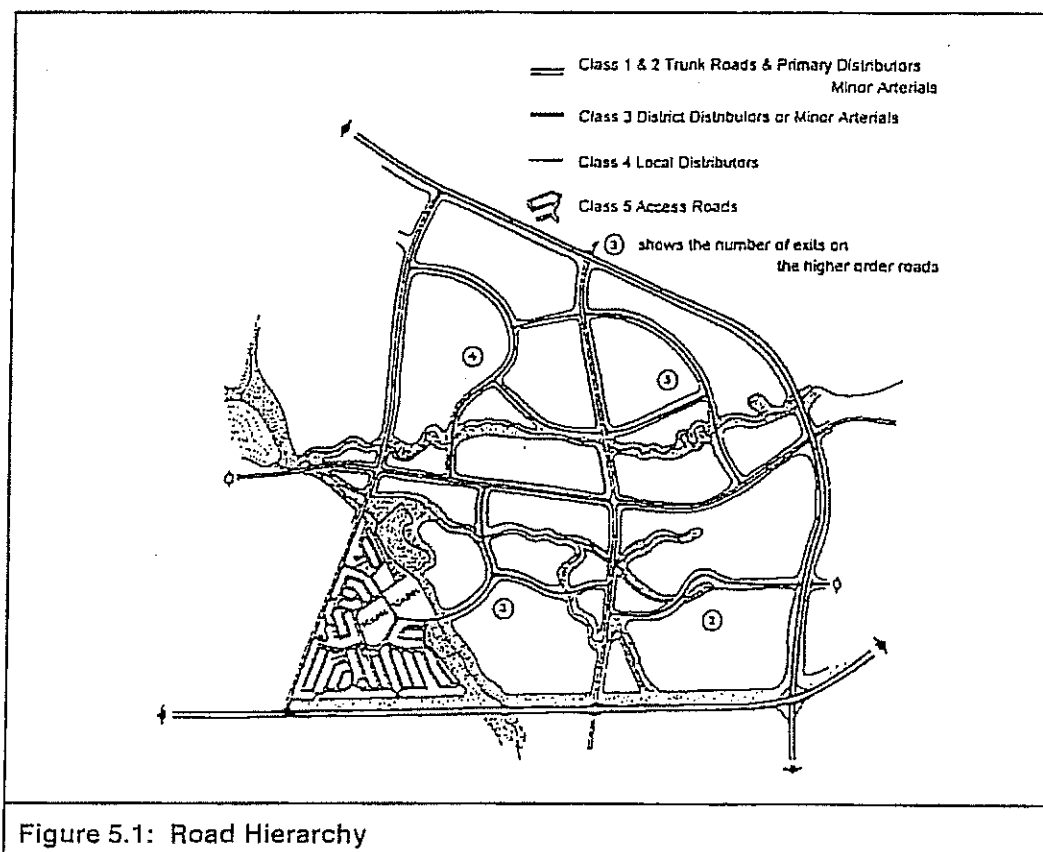

#### Class 1 : Trunk roads (National and regional distributors)

These are generally rural roads whose function is to facilitate the regional distribution of traffic. They may be national or provincial roads and include freeways, expressways, dual carriageways and single carriageway main roads. Continuous sections of these roads in urban areas should be designed as by-pass routes. Route continuity is important.

#### Class 2 - Primary distributors or major arterials

These roads constitute the primary road network for the urban area as a whole. All long distance traffic movements to, from, and within the city should be accommodated on these roads. They are characterised by high traffic volumes, limited access and fairly high speeds. Route continuity is important.

#### Class 3 - District distributors or minor arterials

These roads form the link between the primary road network and roads within the residential and other land use areas. They distribute traffic between the various residential, commercial and industrial districts of the urban area. They should connect areas without passing through them.

## SECTION II

These roads are characterised by high traffic volumes, restricted access and moderate speeds. The major public transport movement is accommodated by these roads which should therefore have the necessary supporting infrastructure (preferably off the travelled roadway). As in the cases of Classes 1 and 2, route continuity is important.

Class 4 - Local Distributors

These are local through routes which distribute traffic within communities and which also link district distributors and access roads. As local bus services can be accommodated on these roads, they should be open ended. Local distributors should accommodate traffic generated by between 400 and 1200 dwelling units. The road layout should discourage extraneous traffic (i.e. there should be no available short-cuts between adjacent class 2 or 3 roads). Access to individual properties should not be encouraged.

These roads should not be continuous between adjacent neighbourhood cells (e.g. through provision of staggered intersections etc.).

Class 5 - Residential access roads

These roads provide direct access to properties within the residential area. Access for motor vehicles is not their only function and the roads are also used by inhabitants for recreational purposes (running, cycling, walking etc.). They also accommodate the provision and maintenance of services and stormwater drains.

These roads are minor roads serving a maximum of 200 dwelling units. They do not require continuous alignments and form part of a closed network. In descending order of priority, the hierarchy of these roads is as follows:

## Class 5a (residential access collector) :

These provide a link between the local distributor and other access roads. They service up to 200 dwelling units and should not provide short cuts for any traffic using the local or district road network. They may be part of an open system or a closed system with one outlet onto the local distributor (i.e. functioning as an access way). Access to properties is allowed where sight distances are not a problem.

## Class 5b (Access loop) :

These carry traffic from about 120 dwelling units, providing a short link for cul-de-sacs, access courts and private roads to a residential access collector. They should not be linked with local distributors. Separate paved footways may be justified in high density, low income areas with high pedestrian volumes. These roads should be designed for joint use by pedestrian and vehicles.



## SECTION II

## Class 5c (Access cul-de-sac) :

These are small informal roads providing direct frontage access to between 6 and 60 dwelling units. They should generally not exceed 150 m in length. They are ideally suited to low to medium density ( $< 500 \text{ m}^2$ ) developments with open plan front gardens and where parking is provided on the property. Again these roads should be for joint use by pedestrians and vehicles. To emphasize this joint use, contrasting design features (e.g. block paving) could be incorporated. Vehicle speeds should be restricted to 20 km/h.

## Class 5d (Access way) :

This is a closed road system with an exit at only one end. It may have variable width (3 to 5 m) and typically carries traffic generated by up to 60 dwelling units. Such roads may link access courts to each other and/or to other class 5 roads. These roads are not intended to provide direct access to single buildings (this is not advised where the road width is less than 4,5 m). The design should ensure consistent low speed and be clearly marked at its entry to demarcate its special character.

## Class 5e (Access court) :

This type of road gives access to about 30 dwelling units and has contrasting designs to indicate shared use. The design should ensure low speed, especially since these roads may be used by children for playing. Access courts are particularly suitable for use in conjunction with access ways at developments where the net density exceeds 16 dwellings/hectare. Access courts may provide links between adjacent access ways to accommodate emergency and service vehicles. General use should be discouraged.

## Class 5f (Access strips):

These are also known as double panhandles and provide access to a maximum of 4 dwelling units. Turning circles are not provided and the roads can be either public or private. Parking should be provided on each property.

## Private roads:

These are not the property of the authorities and the road reserves are determined by the owners of such property. However, these roads should be designed to be consistent with public roads of similar function.

The most important characteristics of the different road classes are shown in Table 5.1.

## SECTION II

DESCRIPTION	CLASS				
	1	2	3	4	5
Characteristics	Predominantly rural	Urban	Urban	Urban	Residential
Linking	Urban areas	Urban districts	Communities	Neighbourhoods	-
Function	Regional distribution	Urban distribution	District distribution	Local distribution	Access
Type of facility	Freeway, dual or single carriageway	Freeway, dual or single carriageway	Dual or single carriageway	Two lane single carriageway	Two lane single carriageway and/or of variable width

## 5.2.3 Layout of the road network

Residential road networks or layouts may take different forms depending on the selection of the various road classes in the hierarchy. The guidelines for the provision of engineering services in residential townships (NHB, 1995 and DCD, 1983) make reference to four network types, namely grid, serial, branching networks and non-network types. Each network has advantages and disadvantages and is applicable to different densities, housing types, topography and climate. However, certain design principles apply to all in the development of an appropriate network, given the environmental conditions. These principles are:

- The layout should as far as possible exclude external (through) traffic, especially HGVs;
- Intersections between high and low order roads should be prevented by ensuring that there is a continuous gradation from one level in the hierarchy to the next;
- The number of higher order roads (which are large and expensive) should be minimised by using lower order roads wherever practical. The proportions of road length between local distributor, residential access collector and local access roads should be < 15%, < 30% and >60%. This would ensure that the maximum cost savings are achieved;
- Roads should preferably intersect with other roads which do not differ by more than one level in the hierarchy. The difference in class level should never exceed 2, and then only in exceptional cases;
- The number of intersections, especially on higher order roads, should be minimised;
- Cross roads on higher order roads should be avoided unless the traffic demand warrants the installation of traffic signals or roundabouts. Where these are not warranted, T-junctions are preferred, with the lower order road intersecting at right angles. Low traffic volumes on the lower order (class 5) roads may justify the use of crossroads;

## SECTION II

- The road layout should consistently give the automatic right of way to traffic on the higher order roads. Straight and continuous sections should therefore be used for the higher order roads, which would then have logical right of way over traffic on the lower order intersecting road;
- Land uses affecting traffic volumes and distribution should be such as to minimise intra-neighbourhood traffic. More intensive traffic generators (e.g. shops, schools, flats, etc.) should not be located so that traffic has to pass more sensitive and less intensive generators (detached dwellings) to gain access to the higher order roads;
- Areas attracting vehicular traffic should be located on local distributors and preferably on the periphery of the area. This would concentrate traffic on the local distributors. The neighbourhood should be served primarily by local access roads;
- Houses should be mainly located on lightly trafficked, low speed roads;
- Bearing the above in mind, the designer should strive to provide easy access to the local distributor by aiming to minimise the number of junction turns (< 3 turns) and travel time (< 1,5 minutes) without allowing speeds to become excessive;
- In addition to vehicles, pedestrians and cyclists should be afforded the same consideration when residential access roads are designed;
- Bus routes and facilities attracting pedestrians should be located so as to minimise walking distances and also to avoid at-grade crossings on busy, higher order roads. Where crossings cannot be avoided, these should be provided with traffic signals.
- Pedestrian circulation networks should be incorporated into the total circulation network. Where road layouts cannot facilitate the most direct route to pedestrian generators, exclusive pedestrian rights of way should be provided;
- Where there are large differentials in speeds of vehicles and other road users and where there are concentrated pedestrian and cycle movements, walkways and cycle paths should be provided within the road reserve. Where vehicle speeds are below 30 km/h, segregation is unnecessary;
- Sufficient parking, which is closer to destinations than alternative on-street parking should be provided. At least one parking space per low car ownership property should be provided with further provision for visitor parking within the road reserve; and
- Emergency and public service vehicles should not have to reverse for distances in excess of 20 metres.

## 5.3 INFORMATION REQUIREMENTS

The implementation of traffic calming schemes impacts on not only an individual street but on the entire area surrounding that specific street. A holistic approach is essential to prevent

## SECTION II

problems being treated from spilling over onto adjacent streets. It is therefore imperative that as much information as possible regarding the study area (defined as that area which may be affected by the implementation of traffic calming measures) be gathered.

Data can be sourced from short to medium term transport plans, land use development plans, traffic studies, accident data bases, aerial photographs, "as-built" plans, vehicle registrations and licence data bases, population and other socio-economic statistics, etc. For the purpose of preliminary and detail investigations, as much of the following information as possible should be obtained:

- accident statistics;
- traffic speeds;
- traffic volumes;
- pedestrian and cycle volumes or routes (e.g. to schools, shops etc.);
- applications/complaints from ratepayers;
- geometric characteristics;
- public transport (including minibus taxis) usage in the affected area;
- parking demand, supply and utilisation;
- land use (especially of sensitive destinations such as schools and shops);
- road signing and marking;
- delivery routes; and
- service routes.

In the case of detail investigations, surveys should be initiated to collect data that are not available. These could include traffic surveys, household opinion surveys, visual inspections, road sign and marking inventories, etc. In all cases it is recommended that all data collected be collated in a standardised manner and stored on a computerised data base and on hard copy.

### 5.4 PROBLEM IDENTIFICATION

Traffic calming projects should be identified within the framework of Transportation Systems Management (NTC, 1988). This would facilitate better planning, investigation, prioritisation, implementation and monitoring of such projects. It would also ensure that traffic calming projects are evaluated within the context of the overall transportation needs in the area.

However, in many cases ad hoc requests are received from the public for the implementation of some measure or measures. Generally these would not have been planned or budgeted for. In this situation the application should still be evaluated and prioritised within the transportation needs framework of that specific year. Only in exceptional circumstances should ad hoc requests be given higher priority than requests already received. Again, it is recommended that the Guidelines for the Transportation Systems Management Process (NTC, 1988) be followed in this process.

#### 5.4.1 Scoping studies

The following check list would assist the designer in obtaining all relevant background data before initiating public involvement during the planning stage:

## SECTION II

- Evaluate applications for traffic calming measures or alternatively adopt a pro-active approach and compile an inventory of areas where traffic calming may be needed;
- Define the study area from topo-cadastral plans showing roads, railways, and services;
- Evaluate development plans and determine the impact of future development on the operation of existing roads (traffic generation etc.);
- Define the road hierarchy and establish that roads within the study area function according to the desired hierarchy. This means that volumes, vehicle classes and Origin-Destination patterns would have to be determined. Historic data should also be obtained to determine whether there has been sustained growth in traffic and the reasons for this growth. If traffic data on the specific road under consideration are not available, then at least data for surrounding higher order roads should be obtained to get an indication of possible capacity related problems on the higher order network. If not available, these should be measured as part of the before studies;
- Determine what proportion of traffic is non-local, whether speeds are excessive, whether collisions have been reported, trends in collisions in the area and possible causes;
- Identify public transport routes and determine the requirements of public transport operators and service operators;
- Identify and assess the likely demand for cycle and pedestrian routes and facilities (e.g. near schools, old age homes, shopping centres etc.);
- Evaluate road link and intersection capacities and identify problems areas. Assess these against short to medium term upgrading plans;
- Determine what provision is made for on and off-street parking;
- Identify interested and affected parties;
- Identify possible calming treatments to relieve the problems; and
- Prepare sketch plans of proposals for discussion with stakeholders.

It is emphasised that this phase should be seen as a scoping exercise and existing data should be used as far as possible. This would include site visits which are often invaluable in identifying system constraints. Subjective judgements from residents would also assist in providing some information regarding the problems and associated causes. The data collected during initial scoping is intended to help determine whether detailed project analysis and design is justified.

A framework for evaluating the feasibility of further investigation is provided on Table 5.2. To some extent this is based on the warrants developed and used extensively by the Cape Town and Bellville municipalities.

## SECTION II

Criteria with the same weights are grouped together and then the four resulting weight groups are used in the calculation. An averaging process is applied to each weight group separately (to accommodate situations where data for certain criteria are unavailable) and the weighted scores for the groups summed to derive a total score for the site.

To calculate compliance with the warrants the following calculation is used to determine the weighted score:

$$TS = \sum_{j=1}^5 \left( \sum_{i=1}^{n_j} P_{ij} W_{ij} \times \frac{n_j}{N_j} \right)$$

Where :

- TS = weighted total score for site in question
- $P_{ij}$  = point for criterion i in weighting group j
- $W_{ij}$  = weight for criterion i in weighting group j
- $n_j$  = number of criterion in weighting group j
- $N_j$  = number of criterion under consideration in weighting group j
- i = various weighting groups - 1, 2, 3 and 5

The weighted score can be used as follows to determine whether the proposed measures are warranted:

Condition 1 : Score below 32 points	Not warranted for implementation or further investigation
Condition 2 : Score between 32 and 43	Further investigation
Condition 3 : Score above 43	Warranted for implementation

It should be noted that the above evaluation is intended to eliminate unnecessary data collection and detail investigation. As far as possible existing data should be used. In cases where these data do not exist, the project team should make realistic estimates or, alternatively, conduct small studies to limit costs.

## SECTION II

Table 5.2 : Warrants for Testing the Feasibility for Detail Investigation				
Guidelines for evaluating feasibility				
CRITERIA	Point score			Weight
	0	1	2	
1 Traffic volumes*	<150 vph	150-600 vph	>600 vph	3
2 EAN (per 10 <sup>3</sup> veh-km)	<10	11 - 70	>70	3
3 Public service vehicles	> 5 vph	3 - 5 vph	< 3 vph	1
4 Pedestrian risk	Low	Medium	High	2
5 85th percentile speed*	< 60 km/h	60 - 70 km/h	>70 km/h	5
6 Through traffic volume	< 5 %	5 - 50 %	> 50 %	5
7 Pedestrian volumes (Vol/4h over 150 m)	< 250/4h	250 - 500/4h	>500/4h	3
8 Parking/loading movements	<100/h/km	100 - 200/h/km	>200/h/km	1
9 Schools/playgrounds	No	-	Yes	2
10 Footway/verges	Made	Rough	None	2
11 Frontage/accesses spacing	>75 m	50 - 75 m	<50 m	2
12 Sensitive area	No	Slightly	Yes	1
13 One or two-way	One		Two	1
14 Stopping sight distance	>130 m	50 - 130 m	< 50 m	1
15 Gradient	>5%	3 - 5%	<3 %	1
16 Road type	5 (b-a)	5a	4	3

- Where :
- Traffic volumes = Average hourly peak traffic volumes between 06:00 and 18:00.
  - EAN = Equivalent accident number (calculated as shown in Section V, Appendix F).
  - Public service vehicles = Average peak hour volumes (buses, refuse removal trucks, etc.).
  - Pedestrian/risk = The potential risk that pedestrian and vulnerable road users are exposed to in the presence of traffic can be subjectively assessed, (e.g brake lights, swerving etc.).
  - 85th percentile speed = The speed at or below which 85 per cent of the vehicles travel.
  - Through traffic volume = That proportion of traffic that has neither an origin or destination along the road, or within the area, under study.
  - Pedestrian volumes = The volume of pedestrians crossing a road over a four hour period and measured over a 150 metres roadway length.
  - Schools/playgrounds = The presence of schools/creches/playgroups etc. within the study area.
  - Footway/verges = The provision of pedestrian facilities (pavements etc.) within the verges.

## SECTION II

Frontage/access spacing	=	The average distance between accesses to properties within the studied area/road.
Sensitive area	=	The presence of hospitals, old age homes, clinics etc. and other facilities that may be sensitive to traffic, traffic noise, fumes etc.
One or two-way	=	Whether roads accommodate two or one-way traffic flow.
Stopping sight distance	=	The minimum distance required for a driver to bring his vehicle to a standstill, based on speed, driver reaction time and skid resistance (See Section V).
Gradient	=	The vertical rise or fall of the roadway measured from the base to the apex and expressed as a percentage.
Road type	=	Based on recognised road class classification
* NOTE: At sites where:	a)	speeds fall in the highest category and volumes in the lowest category, exclude volume from the calculation; and
	b)	volumes fall in the highest category (> 600 vph) and speeds in the lowest category (< 60 km/h), exclude speed from the calculation.

Speeds are influenced by traffic volumes and for these extremes sites with high speed or high volume would be penalised by low volume and low speed.

#### 5.4.2 Public participation

Based on the sketch plans developed in the preliminary investigations, prepare opinion survey questionnaires outlining the proposals. Ensure that the questionnaire is designed so as to convey the intent of the scheme and explains the reasons behind it. The opinion surveys should be conducted amongst all categories of road users, as well as among residents in the affected area. A minimum sample of 10 per cent should be drawn. The survey technique for road user surveys may take the form of roadside surveys or questionnaires distributed to road users and collected on a specific day (preferably the next day) after distribution.

Surveys among residents may be personal, postal or telephonic and should be conducted at least three months before the detailed data collection phase is initiated. This is also required in terms of rating the future viability of the proposed scheme (Section 5.9). The sample should be drawn randomly throughout the study area and at least a 10 per cent response should be realised. Respondents should be provided with the necessary background regarding the proposed implementation of measures. The questionnaire should be short and open-ended questions should be avoided. (An example is shown in Appendix B).

The analysis of the survey results should indicate that residents in the study area support the proposed treatments.

#### 5.4.3 Detailed studies

Based on the acceptance criteria for initiating the detail studies (Sections 5.4.1 and 5.9) the planning or detail investigation can be initiated. Traffic studies should be planned to collect all relevant data (traffic volumes, O-D, speeds, pedestrian and cycle volumes etc.) and structured so that the detail study results can be used as a before study which should be comparable to the after study (see Section 5.7 for detail of before and after studies).



## SECTION II

In all cases the designer should liaise closely with persons responsible for land use and transportation planning. During the problem identification phase, the following actions should be undertaken as part of the detailed study:

- identify the scope of the problem (i.e. is it at local, corridor or area-wide level);
- collect all relevant data and superimpose this on an area base map;
- define the goals and objectives of the project;
- determine the relationship between perceived or measured problems and identify the underlying causes; A final step in this process is to produce a status quo report which describes the existing situation in terms of traffic, road hierarchy, road safety and other issues (such as resident and road user opinion). Identified problems should be indicated and the cause and effect explained. In some cases, depending on the scale of the investigation, it may be necessary to use traffic or transportation planning software to model and calibrate the existing situation. Examples of such models include EMME-2, CONTRAM, SATURN, etc.

### 5.5 PREPARATION OF SOLUTIONS

The primary input of this stage is the status quo report prepared during problem identification. Based on the identified problems, engineering alternatives can be identified to address the objectives of the study.

From these, applicable traffic calming measures can be selected (Chapter 6 and 7) for testing. The following tasks would need to be done:

- develop solutions for the underlying causes and establish whether these would resolve the problems;
- identify traffic calming measures (see Chapter 6 and 7) in support of the above solutions where necessary;
- develop alternatives for implementation;
- test the impact of the above on current and future utilisation;
- discuss proposed solutions and impacts with town planners and ensure that these do not run counter to the short to medium term transportation and land use plans;
- prioritise the alternatives using cost-benefit analysis as a basis; and
- select the most feasible and cost-efficient alternative.

## SECTION II

### 5.6 PRIORITISATION

It is reiterated that the advantages and disadvantages of the various alternatives can be determined by making use of existing transportation planning and sometimes of traffic engineering software (e.g. Arcady, Simtra). This is especially relevant where implementation impacts on the corridor or area-wide level. In all cases the merits of each alternative should be compared on the basis of the degree to which the measure meets the desired objective, taking into account possible negative impacts on the surrounding network/area.

The specific project should then be evaluated against other projects on the capital or maintenance budgets.

As part of the evaluation it is recommended that the specific project be prioritised against other traffic calming and TSM related projects. It is not the objective of this document to be prescriptive in the prioritisation process. All local and metropolitan authorities have procedures in place for this purpose. However, it is suggested that both cost-benefit and change in amenity be considered in this process. An evaluation matrix, measuring potential improvement and/or benefit against the objectives, can be useful in prioritising specific projects. Such methods are described in the TSM procedures (NTC, 1988).

### 5.7 BEFORE AND AFTER STUDIES

Following the prioritisation process, the extent of data to be collected would become evident. The objectives of the specific study would also indicate the type of data to be collected in the before and after studies (e.g. speeds do not need to be measured if the objective is to reduce through traffic).

Before and after studies should be conducted to evaluate the relative success of the implemented scheme. In both cases traffic and attitudinal data would need to be collected. In all cases the following studies would be required:

- **O-D studies** - Origin-Destination patterns within the study area would need to be determined. Two methods could be used, namely (a) vehicle registration surveys or (b) driver roadside interviews.
  - (a) **Vehicle registration surveys** (Appendix C) are effective for determining both O-D patterns and travel times through the road network. Unfortunately, O-D studies require large numbers of enumerators who would have to be deployed to form a cordon around the study area. It is also suggested that a few enumerators are placed at strategic locations (on roads that are candidate or potential rat run routes) within the study area road network. Surveys should be conducted for at least one day, with sampling during the morning, midday and afternoon peak periods. It is stressed that a vehicle registration survey is based on sampling, since not all vehicles would be recorded or matched. Generally, the survey is designed to sample traffic, thereby improving the likelihood of a high match rate. This can be achieved by selecting only vehicles that have license plates ending in selected numerical digits (each digit representing a 10% sample) or alternatively reading only the first three digits of each number

## SECTION II

plate. In all cases provision should be made for classifying cars, buses, HGVs and minibuses/taxis.

(b) **Driver roadside interviews** (Appendix C) can be done by making use of systematic sampling of vehicles on a specific route or routes. These surveys normally require the help of the local traffic departments since vehicles need to be pulled off the road. A standard questionnaire is used and drivers are interviewed at the roadside. Typical questions such as "where are you coming from and where are you going", would determine the origin and destination patterns.

- **Intersection counts** - 15 minute, classified turning counts (Appendix D) should be conducted at all critical intersections. Critical intersections can be identified as those providing access to the study area as well as those within the network that provide access to alternative routes through the network. Again these should be conducted for the same period as discussed above.

In addition to the above surveys, speed measurements would be required in cases where the objective is to reduce speeds on the road network within the study area. It is recommended that spot speeds on the roads to be treated are measured. This can be done using radar or preferably, using data logging equipment (e.g. TEL, TDL etc) linked to inductive loops. If data logging equipment is used, the measurements can be carried out for a full seven day period since traffic flows, vehicle classes etc. are also recorded. This would not materially affect costs.

Preceding the before and after studies, extensive publicity should be given to the proposed project. Affected road users and residents should be informed about the result of the attitudinal study and proposed measures to be implemented should be introduced.

Following implementation, the studies should be repeated at the same locations as those used for the before studies. After studies should only be initiated two to three months after implementation, thus ensuring that traffic patterns have stabilised and that residents have become fully acquainted with the measures.

## 5.8 MONITORING

Monitoring is essential to the success of traffic calming. As part of this process, selective law enforcement may be applied to ensure compliance with implemented measures, especially those that are not self-enforcing (such as prohibition and access restriction signs). Aspects that require monitoring are:

- vehicle speeds and volumes; and
- complaints, petitions etc. received from residents.

## 5.9 PLANNING FRAMEWORK

The criteria to be considered in the planning and decision making process are shown in Figure 5.2. The decision-making framework summarises the requirements of traffic calming needs studies, as discussed in this chapter.

SECTION II

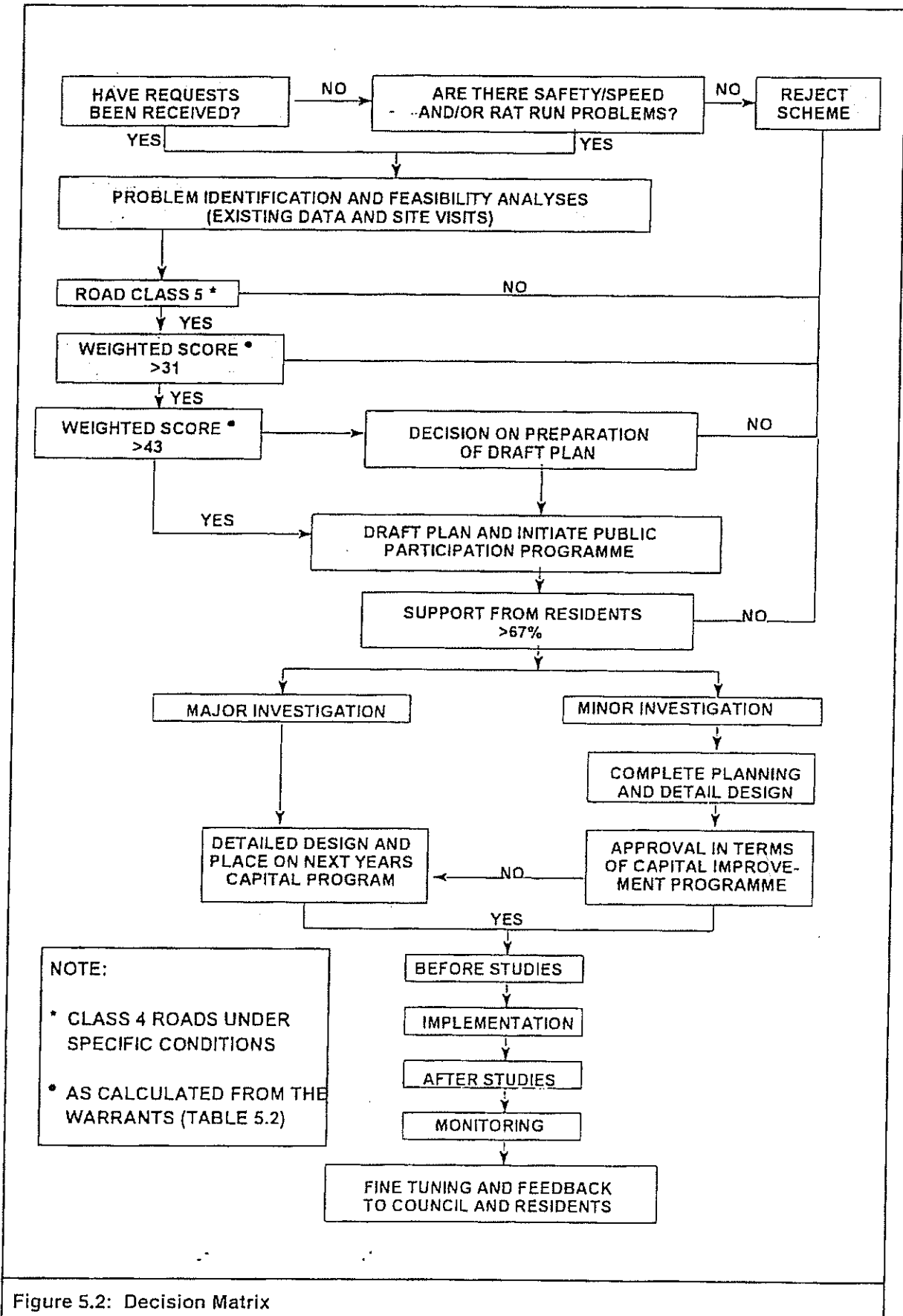

Figure 5.2: Decision Matrix

---

## **SECTION III: SELECTION OF APPROPRIATE MEASURES**

---

The procedures described in Section III are extensively based on, and adapted from, documentation and practices in the Netherlands (CROW, 1988) and this source is gratefully acknowledged.

### **CHAPTER 6: IDENTIFICATION OF APPROPRIATE MEASURES**

In this chapter, algorithms are presented to identify appropriate measures at:

- zones of reduced speed;
- zones of mixed traffic (volume reduction);
- pedestrian crossings; and
- facilities for handicapped persons.

In each case the characteristics of the specific situation are outlined, allowing the user to select the relevant reference pages. The reference pages describe the situation and highlight specific considerations before recommending the applicable measures (described separately on the measure pages - Chapter 7). The measure pages summarise the area of application (conditions describing the initial situation in terms of road widths, volumes etc.) geometric characteristics, implementation, combination possibilities, positive and negative aspects.

The reference pages are coded as follows and discussed in this chapter:

- SR (Speed reducing)
- MT (Mixed traffic)

The reference pages and associated measure pages for pedestrian facilities (Ped.) and provisions for handicapped persons (Han.) are shown in Appendix E. In most cases these are used to complement calming treatments and the designer should not ignore their value.

**Note:** Reference pages describe a given set of conditions for which a number of traffic calming measures may be applicable. Measure pages provide detailed information on specific traffic calming measures (Chapter 7). An explanation of the referencing system is provided overleaf.

Explanatory note to the referencing system:

Reference pages describe a range of conditions and recommend a variety of traffic calming measures that can be implemented under these conditions. The system to the relevant measure is as follows:

EXAMPLE (REFERENCE PAGE SR1: PAGE 6-7):

## 3. Applicable measures

Level	Chapter	Page no.			
		Both sides	Parking method One-sided	None	Not relevant
Road section	TM(Ch7)	22, 61, 64, 69	24, 45, 63, 64	36	21, 25, 26, 28, 29, 66, 67, 71
Intersection	TM(Ch7)	80	80, 81		75, 76, 82, 83, 84
	SM(AppE)				56

TM (Ch7) (under the heading "Chapter"), 22 (under the heading "Both sides") applies to a traffic management (TM) measure that can be used on both sides of a road section. Details of the measure are given in Chapter 7 on page 7-22 (hence 22).

Page no's:

- 7.5 - 7.13: TR - Measures impacting at the town and regional planning level
- 7.15 - 7.102: TM - Traffic management measures for mixed traffic
- E36 - E 51: RU - Traffic provision for separate categories of road users
- E52 - E53: SM - Measures in support of the calming effect
- E54 - E71: CR - Measures aimed at regulatory movement

## 6.1 Technical aspects in mixed traffic

The composition and design of measures provided for mixed traffic are determined by the different traffic categories or classes. Distinction is therefore made between:

- motorised traffic
- pedestrians along the roadway
- cyclists

These categories are not necessarily homogenous. Within each category characteristics can differ significantly from case to case. These differences are evident from:

Motorised traffic	:	Cars, minibus taxis, HGVs, buses, motorcycles, emergency vehicles, service vehicles etc.
Pedestrians	:	Average pedestrian, children, elderly, handicapped, illiterate etc.
Cyclists	:	Young, average, elderly, etc.

It is therefore important to identify those characteristics which would determine the appropriate design for the measure.

One of the most important and effective means of reducing conflicts is to reduce the speed differential between road users as much as possible. In general this implies that high speeds within the residential area need to be reduced. Section 6.1.1 focuses on presenting a system for selecting measures specific to speed reduction.

Section 6.1.2 presents a methodology specific to speed reduction measures applicable to accesses to private properties.

Situations where two or three types of traffic (e.g. motorised + pedestrian) share a roadway then it are referred to as "mixed traffic" (Section 6.2). This therefore implies that there is no exclusive provision for the separate categories and this may give rise to conflicts.

Section 6.2 gives a system for selecting measures appropriate to mixed traffic in more general situations (i.e. not a speed reduced zone and not related to private property access). It relates the traffic function and traffic mix to the associated calming application/s.

### 6.1.1 Algorithm for selecting measures appropriate to speed reduced zones

These are measures aimed at reducing or limiting the speeds of vehicles on typical residential roads (roadway with pavement/verges). Although in South Africa there are as yet no designated low speed zones in residential areas, it is advised that these be seriously considered. The Netherlands and the UK have such speed zoning systems in place. It is therefore important to note that the selection system applies to speed reduced zones only. It is also apparent that as the applied speed limits relate closely to the functional road hierarchy, public resistance may be experienced when adopting the measures to roads with a higher mobility function (i.e. 60 km/h).

The speed reduced zones should comply with the following criteria:

- The maximum speed should be the reasonable result of prevailing circumstances;
- The street/s may not have a through traffic function;
- The operation and functioning of public transport may not be significantly affected;
- The speed zone area may not be confused with the "Woonerf" concept;
- Speed reduction measures may not impede or hinder rapid access for emergency vehicles or the operational efficiency of delivery vehicles loading and/or off-loading goods;
- There should be adequate street lighting to ensure that speed reduction measures are clearly visible at night; and
- The measures may not pose any threat to traffic using them at the posted speeds.

The selection system for speed reducing measures, although summarised from the CROW document (CROW 1988), is based on the original Dutch handbook for 30 km/h zones. Where applicable, the geometric criteria have been adapted to accommodate the South African situation. The algorithm shown in Figure 6.1 is based on three primary categories, namely provisions/measures within the speed reduced zone, gates (access treatments) and traffic management measures.

The following conditions generally apply within the zone:

- traffic flows are low;
- speeds do not exceed the desired speed (typically 40 km/h);
- pedestrian crossings are distributed over the full length of road (i.e. are not concentrated at one or two points); and
- cyclists generally use the roadway.



Since these characteristics are typical in the speed reduced zone, and there is little variation between zones, they are excluded as primary variables in the selection scheme. However, the following are applicable in the selection of traffic calming measures:

- total available street width (roadway plus parking), either less or greater than 8,5 m;
- the function of the street for cycle traffic, either with or without a separate cycle path; and
- the direction of traffic, either one or two-way.

The reference pages introduce two additional characteristics, namely whether the treatment is at an intersection or along a road section and the way in which parking occurs. Since many of these measures are for speed reduction they are also applicable and are often the same as provisions for pedestrians (PED reference pages - Appendix E).

Measures supporting speed reduction treatments have an indirect impact on speed (i.e. by themselves they are not effective) and are therefore not directly referenced.

Since the situation may vary considerably from street to street, the selection system should be applied for each street requiring treatment. Again this emphasizes the need to adopt a holistic approach to prevent problems spilling from one street to the next. For each street under consideration, the following issues should be identified and assessed:

- the scope and/or extent of the residential and traffic function (e.g. only a residential street or one which provides access to another suburb);
- the function of the street;
- traffic composition;
- segregation of pedestrians from other traffic;
- provision of crossing points for vulnerable road users;
- parking need and method of parking;
- the presence of loading facilities and in/out movements;
- the location of gullies, light poles and trees;
- position of services (cables, ducts etc.);
- traffic control and management measures already in force; and
- environmental characteristics.

Should multiple measures be implemented, the following are also important:

- as far as possible, apply measures at intersections;
- the distance between measures should be less than 80 m; and
- apply combinations of measures in such a manner that the positive aspect of one negates the negative aspect of the other.

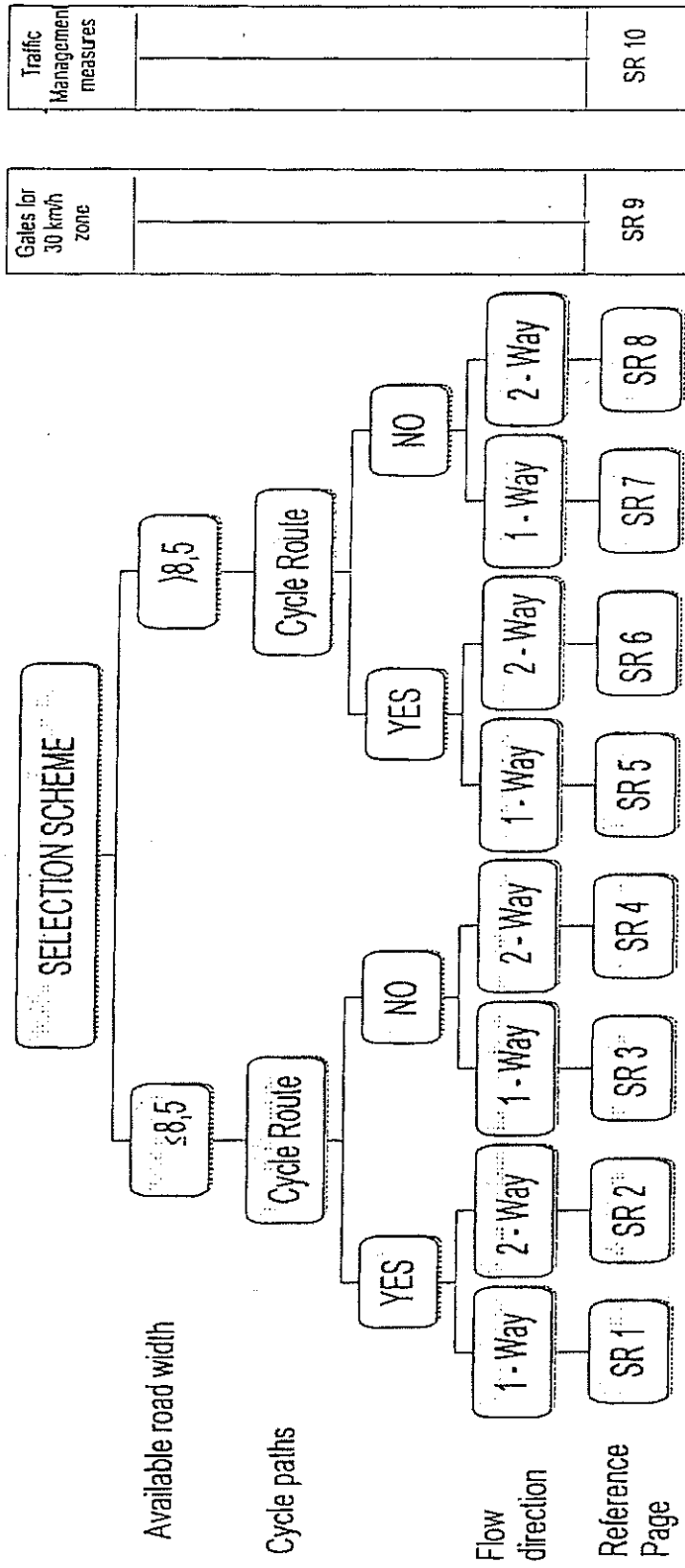

Figure 6.1: System for selecting reduction measures

## REFERENCE PAGE SR1:

## 1. Characteristic

Available width between kerbs  $\leq 8,5$  m (including parking space)  
 Street with important cycling function  
 One-way traffic.

## 2. Considerations

Function of the street (residential or distributor)  
 Vehicle composition  
 Segregation of pedestrians from other traffic  
 Presence of crossings for vulnerable road users  
 Need and method of parking  
 Loading facilities and number of IN/OUT movements  
 Location of gullies, light poles and trees  
 Position of services  
 Traffic management measures in force.

## 3. Applicable measures

Level	Chapter	Parking Method and Relevant Page No's			
		Both sides	One-sided	None	Not relevant
Road Section	TM(Ch7)	22, 61, 64, 69	24, 45, 63, 64	36	21, 25, 26, 28, 29, 66, 67, 71
Intersection	TM(Ch7)	80	80, 81		75, 76, 82, 83, 84
	SM(AppE)				56

Note: The method of parking to be applied is determined by available street width and parking demand. Measures that can be applied on roads where parking occurs may also be applied on roads with no parking.

## REFERENCE PAGE SR2:

## 1. Characteristic

Available width between kerbs  $\leq 8,5$  m (including parking space)  
 Street with important cycling function  
 Two-way traffic

## 2. Considerations

Function of the street (residential or distributor)  
 Vehicle composition  
 Segregation of pedestrians and other traffic  
 Presence of crossings for vulnerable road users  
 Need and method of parking  
 Loading facilities and number of IN/OUT movements  
 Location of gullies, light poles and trees  
 Position of service  
 Traffic management measures in force

## 3. Applicable measures

Level	Chapter	Parking Method and Relevant Page No's			
		Both sides	One-sided	None	Not relevant
Road Section	TM(Ch7)	22, 47, 61, 69	24, 45, 54, 59, 69	33, 36, 47, 53	21, 25, 26, 29, 42, 66, 67
Intersection	TM(Ch7)	80	80, 81		75, 76, 82, 83, 85, 86, 87,
	SM(AppE)				56

Note: The method of parking to be applied is determined by available street width and parking demand. Measures that can be applied on roads where parking occurs may also be applied on roads with no parking.

## REFERENCE PAGE SR3:

## 1. Characteristic

Available width between kerbs  $\leq$  8,5 m (including parking space)  
 Street with unimportant function for cyclists  
 One-way traffic

## 2. Considerations

Function of the street (residential or distributor)  
 Vehicle composition  
 Segregation of pedestrians from other traffic  
 Presence of crossings for vulnerable road users  
 Need and method of parking  
 Loading facilities and number of IN/OUT movements  
 Location of gullies, light poles and trees  
 Position of services  
 Traffic management measures in force

## 3. Applicable measures

Level	Chapter	Parking Method and Relevant Page No's			
		Both sides	One-sided	None	Not relevant
Road Section	TM(Ch7)	64	45, 56, 64, 68	36, 39	21, 25, 26, 28, 29, 60, 66, 67, 71
	SM(AppE)				
Intersection	TM(Ch7)	80	80, 81		75, 76, 82, 83, 84, 89
	SM(AppE)				17

Note: The method of parking to be applied is determined by available street width and parking demand. Measures that can be applied on roads where parking occurs may also be applied on roads with no parking.

## REFERENCE PAGE SR4:

## 1. Characteristic

Available width between kerbs  $\leq 8,5$  m (including parking space)  
 Street with unimportant function for cyclists  
 Two-way traffic

## 2. Considerations

Function of the street (residential or distributor)  
 Vehicle composition  
 Segregation of pedestrians from other traffic  
 Presence of crossings for vulnerable road users  
 Need and method of parking  
 Loading facilities and number of IN/OUT movements  
 Location of gullies, light poles and trees  
 Position of services  
 Traffic management measures in force

## 3. Applicable measures

Level	Chapter	Parking Method and Relevant Page No's			
		Both sides	One-sided	None	Not relevant
Road Section	TM(Ch7)	48	32, 45, 54, 56, 58, 59, 64, 68	33, 36, 39, 47, 53	21, 25, 26, 29, 40, 60, 66, 67, 71
	SM(AppE)				54, 55
Intersection	TM(Ch7)	80	80, 81		75, 76, 82, 83, 84, 89
	SM(AppE)				17

Note: The method of parking to be applied is determined by available street width and parking demand. Measures that can be applied on roads where parking occurs may also be applied on roads with no parking.

## REFERENCE PAGE SR5:

## 1. Characteristic

Available width between kerbs > 8,5 m (including parking space)

Street with important function for cyclists

One-way traffic (Note: one-way traffic on wide streets should be discouraged therefore only limited measures are provided for.)

## 2. Considerations

Function of the street (residential or distributor)

Vehicle composition

Segregation of pedestrians from other traffic

Presence of crossings for vulnerable road users

Need and method of parking

Loading facilities and number of IN/OUT movements

Location of gullies, light poles and trees

Position of services

Traffic management measures in force

## 3. Applicable measures

Level	Chapter	Parking Method and Relevant Page No's			
		Both sides	One-sided	None	Not relevant
Road Section	TM(Ch7)	22, 37, 61, 67	24, 45, 57	36	28, 62, 66, 71
Intersection	TM(Ch7)		77, 78, 79		84

Note: The method of parking to be applied is determined by available street width and parking demand. Measures that can be applied on roads where parking occurs may also be applied on roads with no parking.



## REFERENCE PAGE SR6:

## 1. Characteristic

Available width between kerbs > 8,5 m (including parking space)  
 Street with important function for cyclists  
 Two-way traffic

## 2. Considerations

Function of the street (residential or distributor)  
 Vehicle composition  
 Segregation of pedestrians from other traffic  
 Presence of crossings for vulnerable road users  
 Need and method of parking  
 Loading facilities and number of IN/OUT movements  
 Location of gullies, light poles and trees  
 Position of services  
 Traffic management measures in force

## 3. Applicable measures

Level	Chapter	Parking Method and Relevant Page No's			
		Both sides	One-sided	None	Not relevant
Road Section	TM(Ch7)	22, 37, 46, 48, 61, 65, 59	24, 45, 55, 57, 59, 63	36, 70	21, 25, 26, 28, 29, 33, 41, 42, 47, 48, 51, 53, 62, 66, 67, 71
Intersection	TM(Ch7)	75, 76, 80, 82, 83, 85, 87	77, 78, 79		81, 84, 86

Note: The method of parking to be applied is determined by available street width and parking demand. Measures that can be applied on roads where parking occurs may also be applied on roads with no parking.

## REFERENCE PAGE SR7:

## 1. Characteristic

Available width between kerbs > 8,5 m (including parking space)

Street with unimportant function for cyclists

One-way traffic (Note: one-way traffic on wide streets should be discouraged therefore only limited measures are provided for.)

## 2. Considerations

Function of the street (residential or distributor)

Vehicle composition

Segregation of pedestrians from other traffic

Presence of crossings for vulnerable road users

Need and method of parking

Loading facilities and number of IN/OUT movements

Location of gullies, light poles and trees

Position of services

Traffic management measures in force

## 3. Applicable measures

Level	Chapter	Parking Method and Relevant Page No's			
		Both sides	One-sided	None	Not relevant
Road Section	TM(Ch7)	22	24, 45, 57	36, 39	28, 60, 62, 66, 68, 71
Intersection	TM(Ch7)		77, 78, 79		84

Note: The method of parking to be applied is determined by available street width and parking demand. Measures that can be applied on roads where parking occurs may also be applied on roads with no parking.

## REFERENCE PAGE SR8:

## 1. Characteristic

Available width between kerbs > 8,5 m (including parking space)  
 Street with unimportant function for cyclists  
 Two-way traffic

## 2. Considerations

Function of the street (residential or distributor)  
 Vehicle composition  
 Segregation of pedestrians from other traffic  
 Presence of crossings for vulnerable road users  
 Need and method of parking  
 Loading facilities and number of IN/OUT movements  
 Location of gullies, light poles and trees  
 Position of services  
 Traffic management measures in force

## 3. Applicable measures

Level	Chapter	Parking Method and Relevant Page No's			
		Both sides	One-sided	None	Not relevant
Road Section	TM(CH7)	46, 48	45, 55, 57, 75	36, 39, 70	21, 25, 26, 28, 29, 32, 33, 40, 47, 49, 50, 51, 53, 60, 62, 66, 67, 68, 71
Intersection	TM(Ch7)	75, 76, 80, 82, 83, 85, 87	77, 78, 79		81, 84, 86, 88, 89

Note: The method of parking to be applied is determined by available street width and parking demand. Measures that can be applied on roads where parking occurs may also be applied on roads with no parking.

## REFERENCE PAGE SR9:

## 1. Characteristic

The speed reduced road is a side road of a 60 km/h road (Type 1)  
 The speed reduced road is an extension of a 60 km/h road (Type 2)  
 A combination of Type 1 and 2 (Type 3)

## 2. Considerations

From both the perspectives of traffic circulation and of maintaining the maximum desired speed (typically 30km/h), gates (access/threshold treatments) are necessary on the boundaries of the speed reduced zone. The gates serve:

- to clearly indicate that there are speed reduced zones behind them;
- to impress on non-local traffic that speeds in the zone are markedly lower than on surrounding roads;
- to immediately reduce speeds of vehicular traffic to the required design speed (30 km/h or lower); and
- to prevent uncertainty regarding the priority at the treatment.

It is therefore generally recommended that access/threshold treatments be applied at intersections, since the road user perceives these as the most logical. In principle this allows three possible alternatives, namely:

- gate with exit construction (into higher order road);
- gate without exit construction and regulated with signs; or
- gate 20-30 metres from the intersection.

The last option is applicable where traffic volumes on the higher order road are high or where specific control measures are already in force.

In cases where the speed reduced street is an extension of a higher order road then it is recommended that the speed is not reduced by more than 25 km/h unless other complementary speed reducing measures have been introduced in the higher order road (at a distance of 50 -70 m before the gate).

## 3. Applicable measures

Type	Chapter	Page no.	
		Approach speed (85th %)	
		< 50 km/h	≥ 50 km/h
1	TM(Ch7)	90, 91, 92	
	SM(AppE)	62	
2	TM(Ch7)	93	94, 95
3	TM(Ch7)	96, 97, 98	

## REFERENCE PAGE SR10:

## 1. Characteristic

Road hierarchy and function are unclear.  
Through traffic can enter the area in a number of ways.

## 2. Considerations

The reasons for implementing measures that would influence traffic circulation are:

- to prevent through (non-local) traffic; and
- to lead local traffic as simply and directly as possible to the primary road network and also to minimize the magnitude of traffic.

In these cases the following issues should be considered:

- The distribution of vehicular traffic between the entrances and exits of the residential area. The treatment of streets should not result in high traffic concentrations at one point. It is recommended that an even distribution of traffic throughout the network be achieved;
- Roads through the speed reduced zone with a high pedestrian and cyclist function should have priority when a decision is taken on the measures to be applied (i.e. do not assign these routes to provide access to the primary road network without serious consideration of possible consequences);
- Public transport should be provided with the shortest possible routes through the zone if access from the primary network is insufficient;
- Accessibility to distinctions within the area should be guaranteed, especially for delivery and similar vehicles; and
- All properties should be accessible to emergency vehicles via one or more routes.

## 3. Applicable measures

Type	Chapter
Road Section	TR (Ch7) pages 5-6
Intersection	TR (Ch7) pages 7-12

### 6.1.2 Exits

An outlet onto the roadway can be seen as an exit when:

- the layout design is such that it is clearly recognisable that an exit is intended; and/or
- an access to a property or plot where the specific character and/or limited destination is clearly recognisable.

In all cases the layout should be such that the secondary nature of the exit with respect to the roadway is emphasised. Important factors associated with this are:

- the construction of the transition zone (characterising the level difference) should be located directly next to the roadway;
- pavements and/or cycle paths should, as far as possible, maintain consistency in colour and material over such exits; and
- a small area on either side of the exit intersection with the pavement/cycle path should be paved in the same material as the pavement.

Exits can occur in the following situations:

- From private dwellings, garages, specific plots or commercial facilities.
- From parking lots, streets or erf to the roadway of another street.

Possible implementation measures are:

- Mountable kerb and pedestrian/cycle path next to roadway.
- Kerbed radii or lowered paving strip with cycle/pedestrian path next to roadway.
- No level difference and with or without recessed pedestrian/cycle path.

The relevant measures are shown on pages:

- TM(Ch7) - pg 100
- TM(Ch7) - pg 101
- TM(Ch7) - pg 102

If none of these measures is practical, the inferiority of the exit should be indicated through appropriate priority measures and warning signs.

### 6.2 Selection system for choosing general measures for mixed traffic

The following categories of mixed traffic are referred to in this section:

- Motorised traffic and cyclists;
- Motorised traffic and pedestrians;
- Motorised traffic, cyclists and pedestrians; and
- Pedestrians and cyclists. :

Apart from the type of traffic mix, other dimensions are added to account for the nature of the traffic function. This consists of:

- important traffic function (mobility);
- reasonable traffic function (mobility/access);
- minor traffic function (access); and
- no traffic function (pedestrian).

Figure 6.2 provides an appropriate system for selecting measures that are generally applicable to mixed traffic. It also shows to what degree different classes of road traffic should be permitted to mix.

For conflicts between traffic along and crossing the roadway, please refer to the PED selection system (Appendix E).

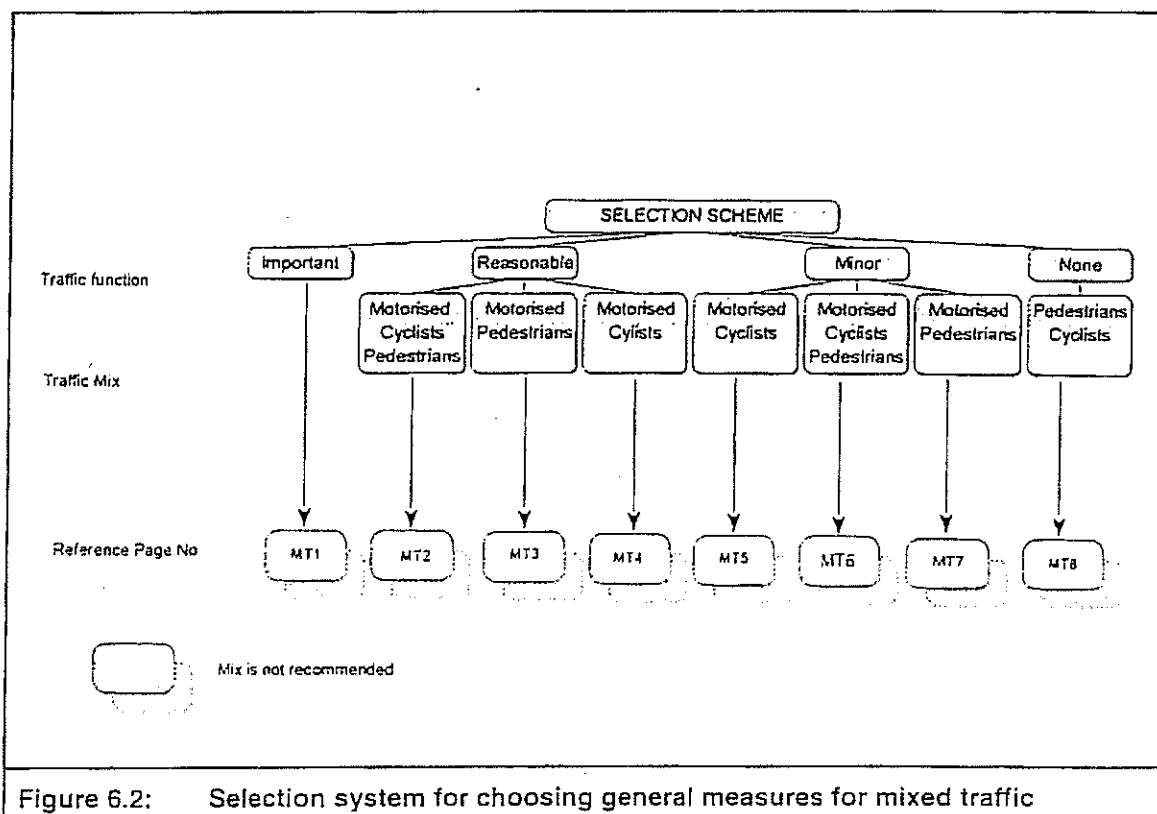

Figure 6.2: Selection system for choosing general measures for mixed traffic

### 6.2.1 Provision for measures impacting at town and regional planning level

This section presents measures that have a major impact on traffic circulation and therefore require assessment in view of the medium to long term transportation plans of the relevant authority. Traffic impacts need to be carefully assessed before implementation.

The measures are:

Measures between intersections : TR1 and TR2 (pages 7-5 and 7-6)  
 Measures at intersections: TR3 to TR9 (pages 7-7 to 7-13)

## REFERENCE PAGE MT1:

## 1. Characteristic of the situation

Important traffic function.

## 2. Consideration in the selection of measures

Because of the important traffic function, segregation of the different traffic components should be actively pursued. As far as possible facilities for the different categories (i.e. motorised traffic, cyclists, pedestrians) should be provided. No specific details are provided in this regard.

## 3. Applicable measures

Motorised traffic:	See section 6
Cyclists on roadway:	See sections 7.2 and 7.3
Cyclists on intersections:	See sections 7.2 and 7.3
Pedestrians:	Refer to pedestrian guidelines (SARB, 1987) and Appendix E.



## REFERENCE PAGE MT2:

**1. Characteristics of the situation**

Reasonable traffic function.

Mixing of motorised traffic, cyclists and pedestrians along the roadway.

**2. Consideration in the selection of measures**

Under these conditions, segregation of pedestrians from other traffic is recommended. Mixing can occur between motorised traffic and cyclists under the characteristics described in reference page MT4. It is however preferable to provide separate facilities under these conditions. Once again these measures are not presented.

**3. Applicable measures**

Refer to sections 7.2 and 7.3 and to the pedestrian guidelines (SARB, 1987)

**REFERENCE PAGE MT3:**

**1. Characteristics of the situation**

Reasonable traffic function.

Mixing of motorised traffic and pedestrians along the roadway.

**2. Consideration in the selection of measures**

It is recommended that, under these conditions, mixing of pedestrians and motorised traffic be avoided. Separate facilities should be encouraged.

**3. Applicable measures**

Refer to sections 7.2 and 7.3 and to the pedestrian guidelines (SARB, 1987).

## REFERENCE PAGE MT4:

## 1. Characteristics of the situation

Reasonable traffic function.  
Mixing of motorised traffic and cyclists.

## 2. Consideration in the selection of measures

This relates to a relatively busy traditional street. Pedestrians are segregated from other traffic by pavements.

The mixing of motorised traffic and cyclists is only acceptable where no immediate alternatives (such as dedicated cycle lanes) are available. However, it should still be investigated whether local measures cannot be accommodated. Heavy goods vehicles and public transport are often accommodated on these streets and careful consideration should be given to the selection of a representative design vehicle. It is also important to distinguish between one-way, limited one-way and two-way traffic.

To limit conflicts (rear end) between bicycles and motorised traffic, attention should be given to the manner of parking. Parking bays should preferably be introduced.

At intersections, capacity and through flow can be improved through the introduction of filter lanes prior to the stop line. These would facilitate displacing weaving to the approaches rather than at the stop line.

Supplementary elements to be provided include crossings and eventually speed reduction. These are only applied incidentally.

## 3. Applicable measures

Layout on roadway and intersection	Refer to UTG1
Crossings	Refer to the pedestrian guidelines (SARB, 1987) and Appendix E (Ped).
Speed reductions	See reference pages SR1 to 10 (pp 6-6 to 6-15)

## REFERENCE PAGE MT5:

## 1. Characteristics of the situation

Minor traffic function.

Mixing of motorised traffic and cyclists.

## 2. Consideration in the selection of measures

These are typical, relatively quiet residential streets. However, pedestrians have separate footways on the verges. Mixing of other traffic is acceptable.

On roads with a relatively minor access (traffic) function, HGV traffic may in certain cases be totally diverted. However, in such instances, there are certain limits and one cannot overlook the fact that deliveries may need to be made, residents sometimes relocate, refuse has to be removed, etc. It is therefore imperative that a suitable design vehicle is selected and consideration be given to the planned directional operation (one-way, limited one-way or two-way). Because of the low traffic intensity, such streets can often be prioritised as speed reduction zones (as discussed in a previous chapter). However, should the objective be to reduce traffic volumes this can be achieved by:

- street closures;
- diagonal closures at intersections;
- turn prohibitions;
- introduction of limited one-way traffic (e.g. chokers);
- length and mass restrictions; and
- speed-reducing measures.

Should the maximum allowable speed be restricted to say 30 km/h, this limit should progressively result from the prevailing circumstances (i.e. systematic introduction of a series of speed-reducing measures). Generally the entrances to a residential area require special attention. The transition from a 50 km/h (60 km/h) to a 30 km/h (40 km/h) road requires an adapted layout to:

- make it clear to road users that a residential area lies behind the gate;
- ensure that non-local traffic are aware of the significantly lower speeds in such areas;
- force an immediate speed reduction; and
- eliminate any uncertainty regarding the priority in the area.

Crossings on these roads are generally not necessary and may be applied as and when required. The presence of bus routes would require slight adaptations to the scheme. These include:

- Adaptation of the bus to local conditions (i.e. travels at the reduced speed);
- Relocation of the bus route to the boundaries of the area; and
- Introduction of a central public transport terminal or similar facility within the area.

## 3. Applicable measures

## CHAPTER AND PAGE

Basic layout of road sections and intersections	Refer to UTG1
Speed reducing measures	Refer to reference pages SR1 to 10 (pp 6-6 to 6-15)
Crossing facilities	Reference to Appendix E (Ped) and pedestrian guidelines (SARB, 1987)

## REFERENCE PAGE MT6:

**1. Characteristics of the situation**

Minor traffic function.

Mixing of motorised, cycle and pedestrian traffic.

**2. Consideration in the selection of measures**

In this situation an even higher priority can be given to the living function of the area than in a speed reduced zone. A street can even be identified as a "Woonerf". This can be achieved by a coherent system of interconnected streets, each treated with comprehensive measures distinguishing it as a unique living area.

Once again, careful consideration should be given to the design vehicle, ensuring that delivery, service, emergency and other such vehicles can reach their required destinations. As speeds in these areas are reduced to walking speed, the design and layout should be such as to ensure that such speeds result logically from the measures implemented. Speed-reducing measures should be introduced on the traditional roads around the area, since these are the transition zones.

With the Woonerf, or the erf as it is now known, there is no separate roadway. Apart from drastic reduction in speed, other facilities such as kiosks, flower pots, lighting etc. are also introduced.

**3. Applicable measures**

Erf  
Speed reduction measures

TM(Ch7) pages 7-28 to 7-33  
Refer to the SR selection system (pages 6-6 to 6-15) but bear in mind that speeds are reduced more drastically (to almost walking speed).

**REFERENCE PAGE MT7:**

**1. Characteristic of the situation**

Minor traffic function.

Mixing of motorised and pedestrian traffic along the roadway.

**2. Consideration in the selection of measures**

This situation is only permitted with the erf concept. This also applies to pedestrian malls and other pedestrianisation schemes. Refer to MT6.

Pedestrian areas often restrict access for motorised traffic. They therefore have a limited traffic function and the eventual design should take account of this.

**3. Applicable measures**

Pedestrian areas

TM(Ch7) pg 7-34

REFERENCE PAGE MT8:

1. **Characteristics of the situation**

No motorised traffic.  
Mixing of pedestrians and cyclists.

2. **Consideration in the selection of measures**

This situation is not relevant to the South African situation and is dealt with in the South African Pedestrian Guidelines.

3. **Applicable measures**

Refer to South African guidelines for pedestrian facilities (SARB, 1987).

**CHAPTER 7: APPLICABLE MEASURES FOR SPEED REDUCED ZONES AND ZONES OF MIXED TRAFFIC**

This chapter contains a catalogue of measures applicable to the situations described in Chapter 6. Each measure is described in terms of:

- Conditions of application;
- Dimensions;
- Implementation;
- Supplementary measures;
- Negative aspects; and
- Remarks.

The measures are provided in specific sub-sections, namely:

- 7.2 Measures that impact on town and regional planning (TR series)
- 7.3 Traffic Management measures for mixed traffic (TM series)

In addition to these primary measures, the following are shown in Appendix F and their merits should not be ignored:

- Traffic management and other measures for specific categories of road users (RU series);
- Measures aimed at the control and regulation level (CR series); and
- Other measures in support of the calming effect (SM series).

Certain traffic calming measures are of a more structural nature and impact on circulation patterns. As they often support traffic management measures but impact on a larger scale, they are presented as measures at town and regional planning level (Chapter 7.2).

The measures presented in these chapters are each presented on a different page. Their format has been standardised as far as possible. These are guidelines that should ensure that measures are applied correctly, while leaving sufficient flexibility for the designer.

The measure pages show diagrammatic representations for each type of traffic calming measure. As many of these are new to South Africa, they need to be assessed and refined for local conditions. Those that have been applied locally are indicated on the relevant pages and their layouts should be adhered to.

**7.1 Measure pages****7.1.1 Conditions for applications**

Distinction is drawn between the conditions and criteria. Conditions are circumstances which should be present to enable the measure to be implemented. Criteria are circumstances which, together, result in the desirability (or necessity) of that measure.

In other words, measures may only be implemented if each condition is satisfied and/or can be adopted in principle if each condition and one or more criteria are met. Conditions and criteria that are not critical are placed between brackets.



### 7.1.2 Dimensions

The widths of measures are determined by:

- speed, which determines the distance between vehicles, which should be taken into account, and
- the chance of meeting certain vehicle types (flows and vehicle composition).

The dimensions provided serve as a guideline and should not be seen as rigid. In most cases these dimensions would be selected on the basis of the design vehicle. Generally, the design vehicle should be a rigid two-axle truck to accommodate service and public transport vehicles, given certain driving speeds. However, lower speeds for these vehicles may be acceptable in many cases.

Turning circle templates for constructing the vehicle path through the devices are provided for both a South African passenger car and a rigid two axle truck (Appendix A). The CAD-based module AUTOTURN could also be used.

### 7.1.3 Implementation

The following aspects are important during the design phase:

- The measure should be conspicuous and recognisable, both during the day and at night;
- Ensure that road users clearly understand how to negotiate the measure;
- Ensure that measures are acceptable by placing and shaping them in a manner that creates an understanding, especially among motorists, of why the measure/s was/were introduced;
- Measures should be safe to negotiate at the design speed;
- Sharp corners should be avoided in the design; slight curves on the edges are recommended;
- Materials for vertical elements and surfaces should be chosen from both a cost and aesthetic perspective; and
- The use of road signs and markings should be limited as far as possible so as to enhance the residential street function.

### 7.1.4 Supplementary measures

Depending on local conditions, care should be exercised not to choose measures in isolation, especially since they may have a limited effect on speeds or may even result in undesirable side effects. The addition of supplementary measures to the engineering measures may achieve the desired result. Examples include:

- Mini roundabouts with speed humps or cushions on high speed approaches;
- Road narrowing assisted by a speed table (physical assisting measures); and
- Use of different surface materials at road narrowing (visual assisting measure).

### 7.1.5 Positive and negative aspects

These provide general comments. It will be noticed that some aspects cannot clearly be defined as positive or negative. This depends on specific goals.









These descriptions provide qualitative statements about the specific measures, many of which are not well known or even used locally. Where known, the effects are mentioned from a road safety and amenity point of view. It is stressed that the effects described relate exclusively to that specific measure. Used in conjunction with supporting measures, better results can be expected.

### 7.1.6 Remarks

These make reference to additional literature on the subject. This literature provides more detail on the specific subject. In many cases existing geometric design and other guidelines are referred to. The remarks also make reference to other possible solutions which may be found on other measure pages.

It should also be noted that the sketches provided are not to be regarded as standard designs. In most cases various alternatives of the layouts provided can be developed. However, the sketches provide focus with regard to the design and layout elements essential to the measure. The sketches have therefore not been drawn to scale.

Symbols and lines common to all sketches generally have the following interpretation (discrepancies are the result of having come from different sources):

	-	property boundary (road reserve);
	-	circular boundary;
	-	directional road markings for cyclist, motorists, public transport;
	-	design element boundary. The shape of the chosen method is determined by the engineer (see points to consider under implementation);
	-	bollards, poles, etc.;
	-	vertical elements (the tree is used as symbol);
	-	street lighting;
	-	asphalt road surface;



- coloured asphalt/concrete;

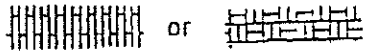

- block paving;

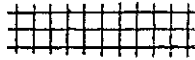

- tiled surfaces;



- cobbles (uneven surface);

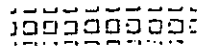

- exceptional surfacing (e.g. small round steel domes, steel bubbles); and



- untreated area (green area).

## 7.2 Measures that impact on town and regional planning (TR1 - TR9)

This section describes measures that may, to a greater or lesser degree, impact on local and/or regional planning efforts. It is again stressed that a holistic approach to problems should be taken to avoid major disruption of established traffic circulation patterns.

It is therefore imperative that transportation and land use planners are consulted during the planning and implementation stages. Depending on the specific objectives, these measures may have far-reaching and long term impacts on local and regional traffic movement.

DESCRIPTION

Road closure with cycle path

MEASURE PAGE

TR1

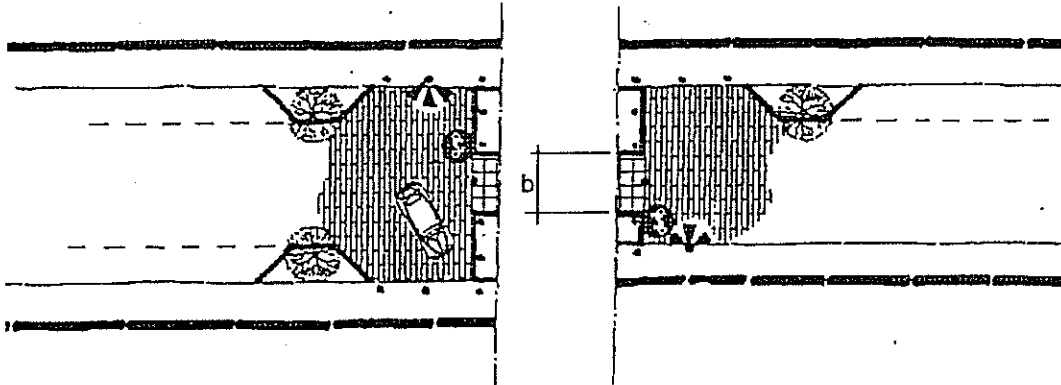
CONDITIONS FOR APPLICATION

- desirability apparent from detailed analysis of traffic circulation and structure
- 85th percentile speed < 50 km/h
- not in priority (higher order) road (between two closely spaced intersections)
- (on cycle route)
- (in situations where crossings often occur)

IMPLEMENTATION

- ensure that the measure is clearly recognisable through use of vertical elements and lighting
- prevent passage over pavements by placing bollards, vertical kerbing, etc.
- for the cycle path (opening) use different materials
- if passage for emergency vehicles is not required, have cycle path on either side of the roadway (See TR4)
- provide adequate turning space for vehicles
- protect poles and bollards (see SM13 and 14)
- signs on both sides (cyclists only - SARTSM) and no entry to vehicles

POSITIVE ASPECTS

- diverts extraneous traffic
- uniform distribution of traffic over higher order access roads can be realised
- dead-end streets discourage speeding and improve driver behaviour

REMARKS:

Ref. Pages: SR10  
Literature: SARTSM, UTG1

DIMENSIONS

- b = 2,5 m  
or  
b = 2,7 - 30 m where emergency vehicles require access

ASSISTING MEASURES

Visual support: see TR10 and SM18

NEGATIVE ASPECTS

- limits route choices for car drivers
- has a negative effect on service vehicles
- parking can occur in the turning area
- reduction in parking space (generally not applicable in South Africa)

DESCRIPTIONMEASURE PAGE

Road closure with cycle path and bus sluice

TR2

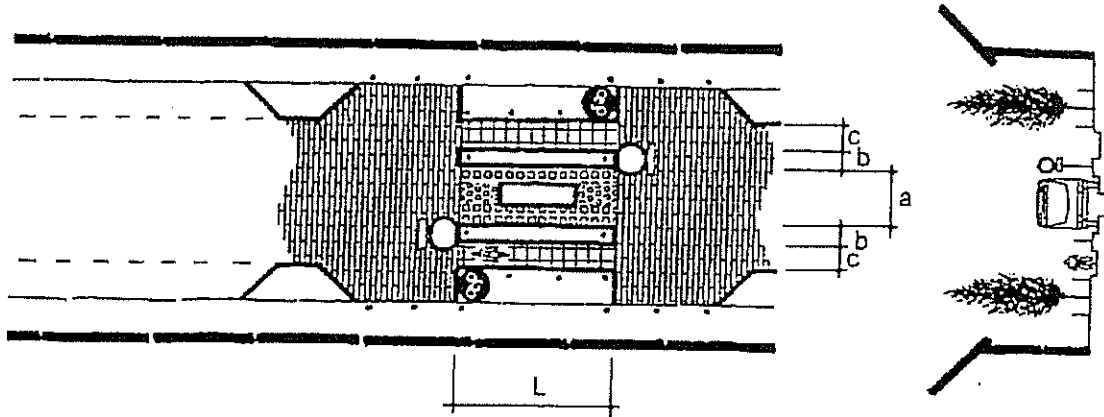
CONDITIONS FOR APPLICATION

- desirability apparent from detailed traffic analysis (distribution, circulation)
- 85th percentile speed < 50 km/h
- not in priority (higher order) road (between two closely spaced intersections)
- (on cycle route)
- (in situations where crossings often occur)

DIMENSIONS

a =	2,7 - 3,25 m
b =	0,85 m
c =	1,35 m
L =	5 to 10 m

IMPLEMENTATION

- responsibility/liability should be self apparent
- ensure recognition through the use of vertical elements and lighting
- prevent passage over pavements/kerb by placing bollards, vertical kerbing, etc.
- construct the cycle path and bus sluice with contrasting paving materials
- provide adequate turning space for vehicles

ASSISTING MEASURES

Visual support; see TR10 and SM18

POSITIVE ASPECTS

- larger service vehicles can cross the sluice
- diverts extraneous traffic
- improved and more uniform distribution of traffic over the higher order access roads is possible
- speeding is discouraged and dead-end streets improve driver behaviour (speeding)

NEGATIVE ASPECTS

- limits route choices for cars
- HGV through traffic can pass over the sluice
- parking in the turning area
- reduction in parking space (generally not applicable in South Africa)

REMARKS:

Ref. Pages: SR10  
Literature: SARTSM, UTG1

DESCRIPTION

MEASURE PAGE

One-way traffic at intersection

TR3

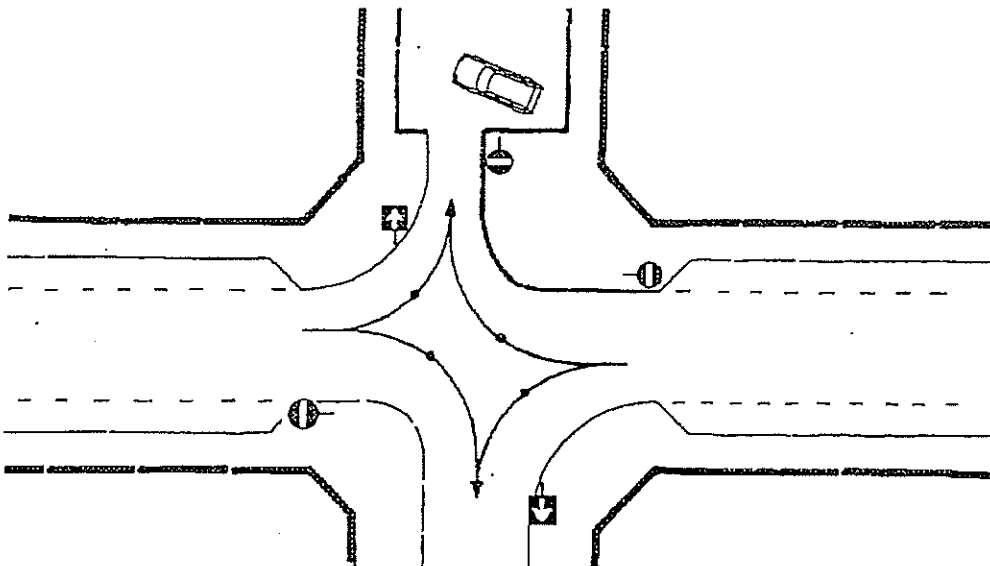

CONDITIONS FOR APPLICATION

- desirability apparent from detailed traffic analysis (distribution, circulation)

DIMENSIONS

a		Reasonable traffic function	Minor traffic function
2 way traffic	Pass. car 2 axle rigid	5,5 - 6,5 m 6,5 - 7,5 m	≥ 4,5 m ≥ 5,5 m
1 way traffic	Pass. car 2 axle rigid	3,25 - 3,5 m 3,5 - 4,25 m	≥ 3,25 m ≥ 4,00 m

IMPLEMENTATION

- eventually modify the lane widths
- on corners between streets where no traffic movements occur, apply small (tight) radii
- with a one-way system aim to minimize through movements at intersections
- try to accommodate two-way cycle traffic

ASSISTING MEASURES

POSITIVE ASPECTS

- diverts extraneous traffic
- possible improvement of traffic distribution on the higher order (access) roads
- possible improvement in provision for parking and "green" zones

NEGATIVE ASPECTS

- limits route choice
- possible increase in speed because of improved flow
- lower driver attention levels
- one way traffic over a short distance is soon disregarded
- disruptive for service vehicles

REMARKS:

Ref. Pages: SR10  
Literature: UTG1, SARTSM, CROW, TRL

DESCRIPTIONMEASURE PAGE

Closure of Intersection approach and cycle paths

TR4

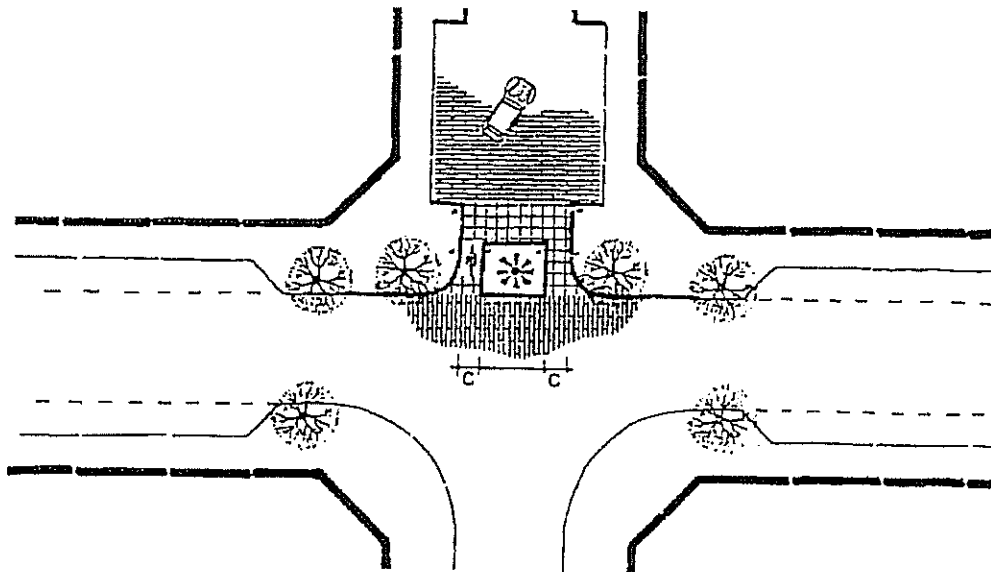
CONDITIONS FOR APPLICATIONDIMENSIONS

- desirability apparent from detailed traffic study (distribution, circulation, etc)
- not on higher order (priority) roads
- 85th percentile speed < 50 km/h

c = 1,35 m

IMPLEMENTATIONASSISTING MEASURES

- ensure recognition through the use of vertical elements and lighting
- prevent passage over pavement or kerb by placing bollards and/or vertical kerbing
- use contrasting paving materials for cycle path
- should emergency vehicles require access, use a central cycle lane with collapsible poles (See TR1)
- provide adequate space for turning
- apply cul-de-sac and cyclist only signs

POSITIVE ASPECTSNEGATIVE ASPECTS

- diverts extraneous traffic
- improved traffic distribution on higher order access roads
- improves traffic speed patterns

- limits route choice for cars
- higher speeds on through road
- parking within turning area
- disruptive for service vehicles
- reduction in parking space (not always applicable in RSA)

REMARKS:Ref. Pages:  
Literature:SR10  
UTG1, SARTSM, CROW, TRL

DESCRIPTION

Closure of intersection approach and one-sided narrowing

MEASURE PAGE

TR5

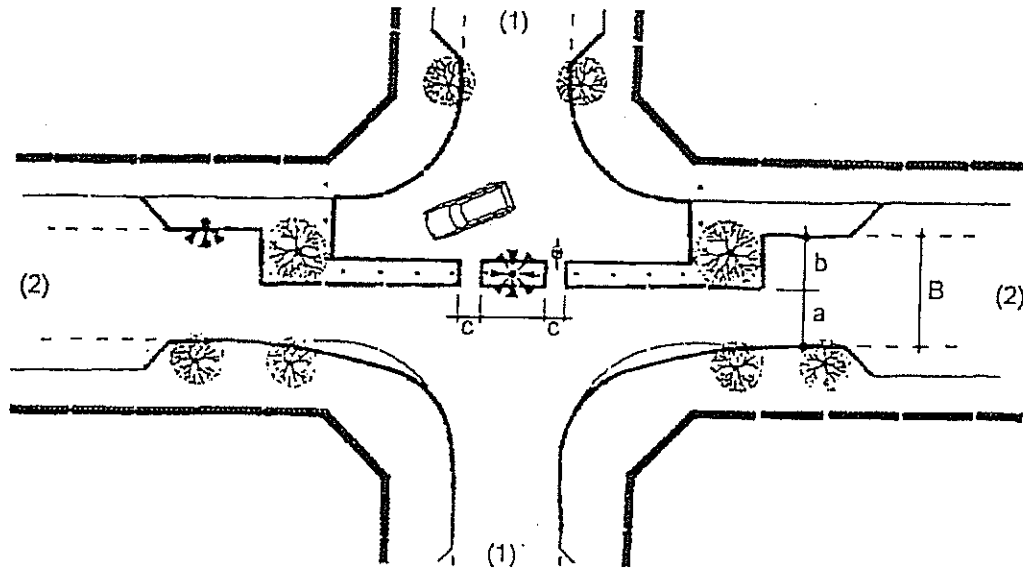
CONDITIONS FOR APPLICATION

- desirability apparent from detailed traffic analyses (traffic circulation, distribution etc.)
- $B \geq 4,25$  m
- Volumes (2) < 600 vehs/peak hour
- 85th percentile speed (2) < 50 km/h
- 1 and 2 not major roads (higher order)
- no cycle route (2)
- (Two-directional traffic on (2))
- warrants for implementation met

DIMENSIONS

- a = 2,75 - 3,25 m
- b = 1,5 m
- c = 1,35 m

Kerb radii would vary, based on the design vehicle

IMPLEMENTATION

- ensure conspicuity through the use of vertical elements and lighting
- ensure good visibility on (2) for oncoming traffic
- on (1) prevent use of pavement or kerb through placement of bollards/poles etc
- on (1), emergency route use central cycle lane with collapsible poles (see TR1)
- apply cut-de-sac and cyclist only signing

ASSISTING MEASURESPOSITIVE ASPECTS

- diverts extraneous traffic on (1)
- reduction in crossing distance (2)
- reduction in speeds on (2), depending on traffic volume
- closure of (1) may improve traffic distribution on higher order roads

NEGATIVE ASPECTS

- limits route choice for cars
- reduces accessibility for service vehicles
- possible increase in speed (2), depending volumes
- parking on turning area
- reduces space for cyclists (2)

REMARKS:

Ref. Pages: SR10  
Literature: UTG1, SARTSM, DOT, TRL



DESCRIPTION

Median closure of intersection and cycle paths

MEASURE PAGE

TR6

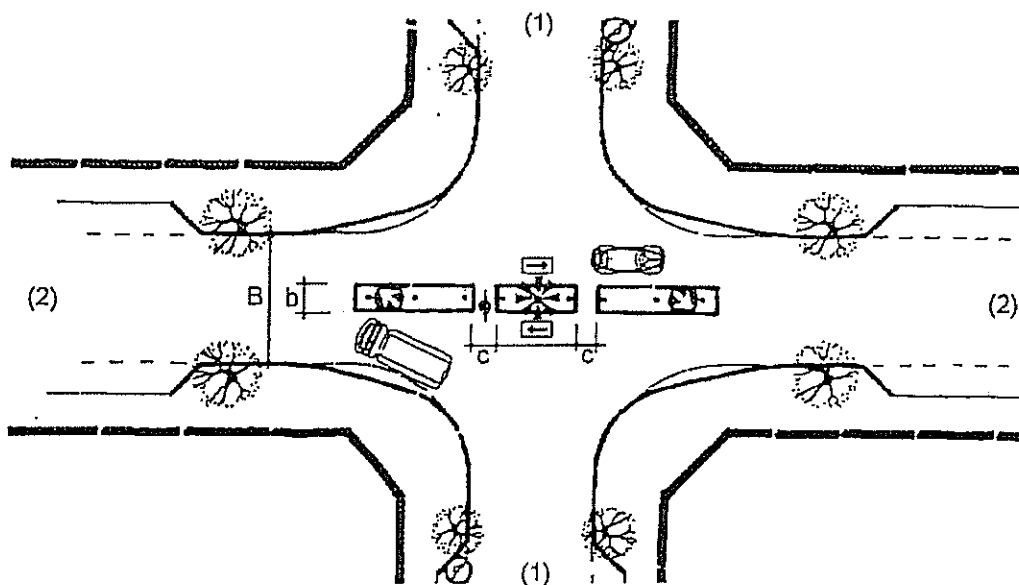
CONDITIONS FOR APPLICATION

- desirability apparent from detailed traffic analysis (circulation, distribution etc.)
- $B \geq 7,0$  m
- two-way traffic on (2)
- low right-turning volumes
- (1) should be a lower (minor) order road

DIMENSIONS

$$b \geq 1,5 \text{ m}$$

$$c = 1,35 \text{ m}$$

Median length such that a passenger car cannot turn around it in one movement.

Kerb radii dependent on design vehicle

IMPLEMENTATION

- (2) place median symmetrically
- ensure conspicuity through the use of vertical elements and lighting
- use different colour paving materials (on road surface) for cycle path
- on (1), emergency route, place cycle path in centre of median and provide collapsible poles (see TR1)
- keep left signs, no right turn signs, cycle crossing

ASSISTING MEASURES

Visual support: see SM10 and SM19

POSITIVE ASPECTS

- diverts extraneous traffic
- possible improvement of traffic distribution
- crossing on (2) can occur in stages
- moderate speed reduction (2)
- high speed reduction (1)

NEGATIVE ASPECTS

- limits route choice for cars
- hinders service vehicles (1)
- limited construction space on median
- right turning traffic can pass in front of median
- motorists are less aware of bicycles crossing from (1)

REMARKS:

Ref. Pages:  
Literature:

SR10  
UTG1, SARTSM

DESCRIPTIONMEASURE PAGE

Diagonal closure of intersection and cycle lanes

TR7

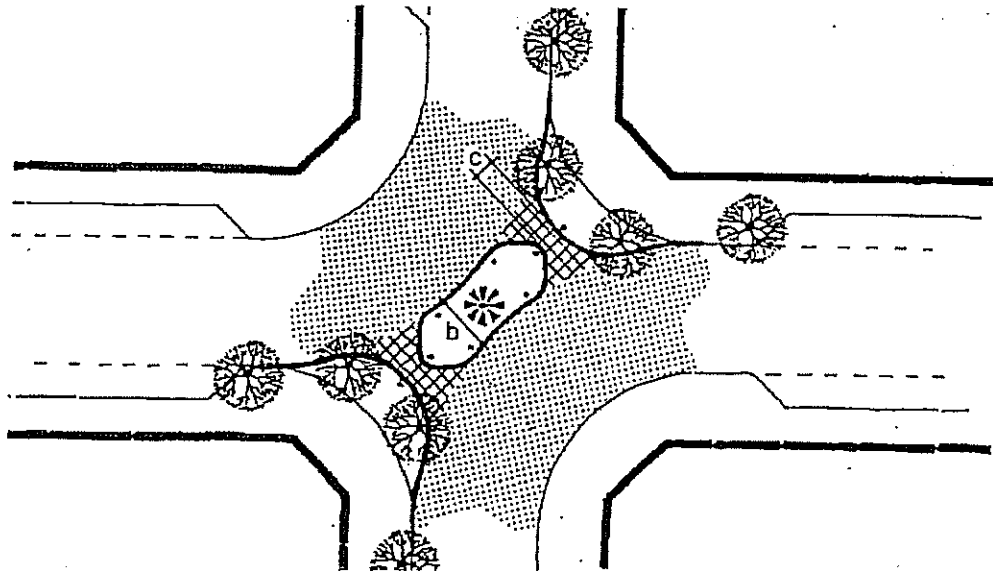
CONDITIONS FOR APPLICATION

- desirability apparent from detailed traffic analysis (circulation, distribution etc.)
- not on major (higher order) road
- not on cycle route

DIMENSIONS

- c = 1,35 m
- b ≥ 1,5 m, depending on the space required for design vehicle

IMPLEMENTATION

- ensure conspicuity through the use of vertical elements and lighting
- ensure adequate visibility for conflicting traffic around the bend
- if emergency route, place cycle lane in centre of intersection with collapsible poles (see TR1)
- signs (hairpin bends, speed reduction, etc)

ASSISTING MEASURESPOSITIVE ASPECTS

- diverts extraneous traffic
- possible improvement of traffic distribution
- effectiveness for speed reduction
- possible to cross intersection diagonally

NEGATIVE ASPECTS

- limits route choice for motorists
- drivers are less aware of through cycle traffic

REMARKS:

Ref. Pages: SR10  
Literature: UTG1, SARTSM

DESCRIPTION

Closure of intersection with star diverter and cycle lanes

MEASURE PAGE

TR8

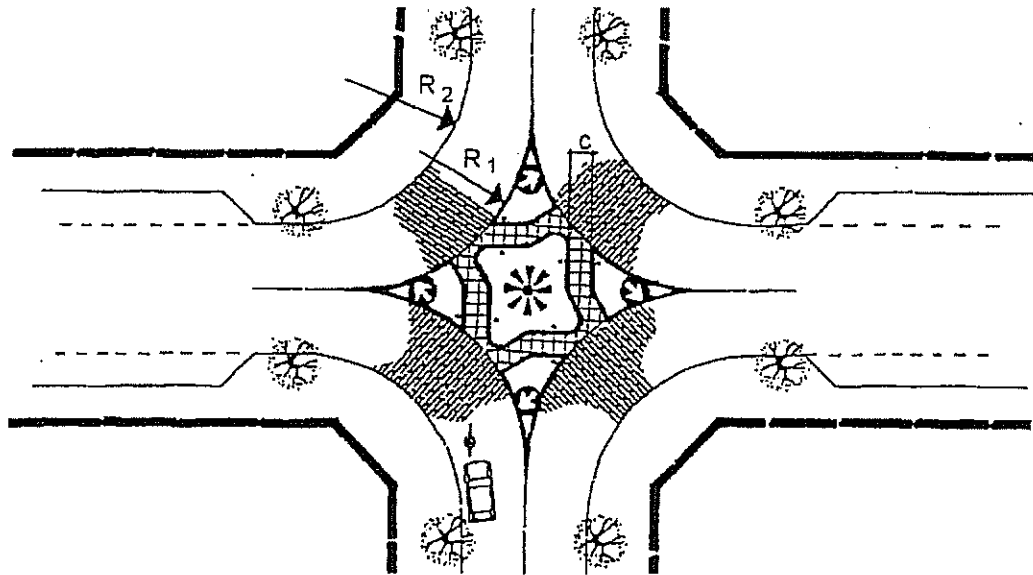
CONDITIONS FOR APPLICATION

- desirability apparent from detailed traffic analysis (circulation, distribution etc.)
- not on major (higher order) road
- not on cycle route
- low right turning volumes

DIMENSIONS

$c = 1,35 \text{ m}$   
 $R_1$  and  $R_2$ , depending on design vehicle.

Length of the island should be such as to prevent passenger cars from turning around it in one movement!

IMPLEMENTATION

- ensure conspicuity through the provision of vertical elements and lighting
- contrast pavement colours of cycle path
- road signs (no right turn etc)

ASSISTING MEASURESPOSITIVE ASPECTS

- diverts extraneous traffic
- improves traffic distribution on higher order roads
- effectiveness for speed reduction
- can cross intersection diagonally

NEGATIVE ASPECTS

- limits route choice
- motorists less aware of through cyclists
- right turning traffic can pass in front of island
- right turning cyclists have to use the roadway

REMARKS:

Ref. Pages:  
 Literature:

SR10  
 UTG1, SARTSM, Parow (Straat parke)

DESCRIPTIONMEASURE PAGE

Closure of staggered junction, with bus sluice and cycle paths

TR9

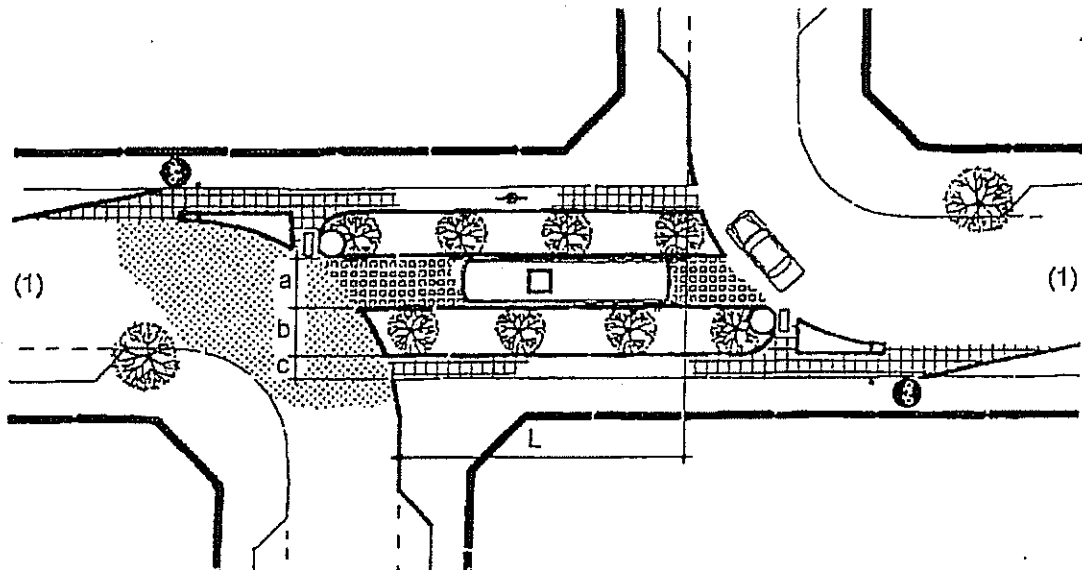
CONDITIONS FOR APPLICATION

- desirability apparent from detailed traffic analysis (circulation, distribution etc.)
- 85th percentile speeds < 50 km/h
- not on major road
- bus route on (1)

DIMENSIONS

- a = 2,7 - 3,25 m
- b = 2,5 m
- c = 1,35 m
- L ≥ 18,0 m

IMPLEMENTATION

- must clearly show responsibility/liability
- ensure conspicuity through the provision of vertical elements and lighting
- prevent passage over pavement through use of bollards, poles, etc.
- alternate and contrast paving materials on sluice and cycle path
- bus sluice (see TR2)
- signing (SARTSM)

ASSISTING MEASURESPOSITIVE ASPECTS

- service vehicles can pass over sluice
- diverts extraneous traffic
- improves traffic distribution on higher order roads
- simple crossings

NEGATIVE ASPECTS

- limits route choice
- through HGV traffic can pass over the sluice
- reduction in parking (not relevant in the RSA)

REMARKS:

Ref. Pages: SR10  
Literature: UTG1, SARTSM, CROW

### 7.3 Traffic Management measures for mixed traffic

This chapter includes measures which relate to traffic management techniques for use in mixed traffic.

The land use function and the traffic function result in variations within a specific area. It is seldom found that the residential and traffic functions are the same throughout an area. One generally finds that streets have predominantly a mobility (traffic) or an access (residential) function. For these purposes this chapter makes a distinction between:

- Measures for pedestrian areas and erven (TM1 - TM6)

No separate pavements are provided for pedestrians. Limited vehicular access is permitted, although pedestrians have priority.

- Additional measures on road links (TM7 - TM60) and intersections (TM61 - TM76)

The traffic function is dominant in this case although the residential function should be protected. Generally this applies to situations where traffic management measures are required to slow or even reduce traffic and also to improve pedestrian mobility across roads.

- Measures for transitional zones (TM77 - TM88)

These are intended for those areas where the traffic and residential functions are mixed, typically found on the boundaries of residential areas.

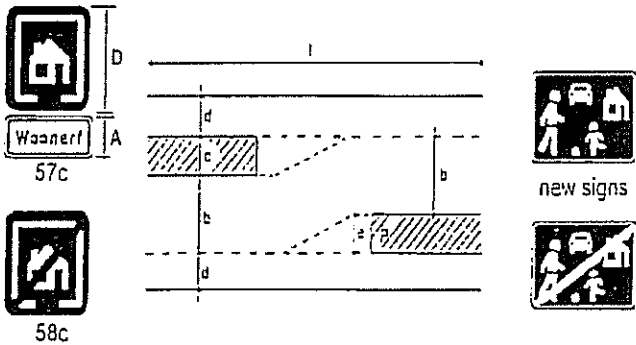
DESCRIPTION	MEASURE PAGE
Woonerf	TM1
	

CONDITIONS FOR APPLICATION	DIMENSIONS
<ul style="list-style-type: none"> <li>residential land use</li> <li>no through traffic</li> <li>volumes &lt; 100vph</li> <li>not on bus and/or delivery routes</li> </ul>	<ul style="list-style-type: none"> <li>l - with one-sided opening &lt; 200 - 400 m</li> <li>l - with two-sided opening = 400 - 600 m</li> <li>a - gable protection = 0,6 m</li> <li>b - traffic lane &gt; 3,0 m</li> <li>c - (obstacles): variable</li> <li>d - walkway &gt; 1 m, over a short length and &gt; 1,50 m over greater length</li> <li>e - width of parking bay</li> <li>D - 40 or 60 cm</li> <li>A - 16 or 23 cm</li> </ul>

**IMPLEMENTATION**

- should preferably form part of a traffic circulation plan for a larger area
- no division in traffic lane and walkway
- sight distance - no blocking of view
- entrances and exits to be clearly visible (see TM86)
- sufficiently marked parking areas
- safely passable speed reducers distanced  $\leq 50$  m apart
- sufficient lighting
- playgrounds to be marked and fenced
- signs - SARTSM
- for various services see TM2 - 5

**POSITIVE ASPECTS**

- relatively safe
- creates a good living climate

**ASSISTING MEASURES**

- hump(s): see TM 13
- facilities for the handicapped

**NEGATIVE ASPECTS**

- high expectations and perceptions cause negligence and reduce safety
- expensive when restructuring from a traditional profile
- lasting problems with motorcycles
- as lengths increase, more irritation for motor traffic, increased speeds, increased intensity, orientation problems
- maintenance

**REMARKS:** Ref. Pages: MT6  
Literature: CROW, SARTSM, Parking and Pedestrian guidelines, UTG1

DESCRIPTIONMEASURE PAGE

Intersection in erf

TM2

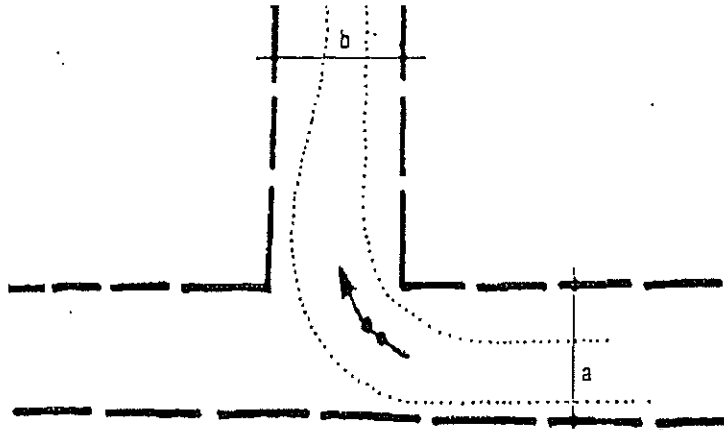
CONDITIONS FOR APPLICATION

+ even

DIMENSIONS

- use fire engine as design vehicle  
(11,2 m long, 2,50 m wide)
- a = 4,65 m for one way traffic  
= 6,15 m for two-way traffic
- b = 6,15 m

IMPLEMENTATION

See TM1

ASSISTING MEASURESPOSITIVE ASPECTS

- assures minimal accessibility for large vehicles

NEGATIVE ASPECTS

- relatively large area required to remain open: it is tempting to use this for parking

REMARKS:

Ref. Pages:

MT6

Literature:

SARTSM, UTG1, CROW

DESCRIPTIONMEASURE PAGE

Passing area in erven

TM3

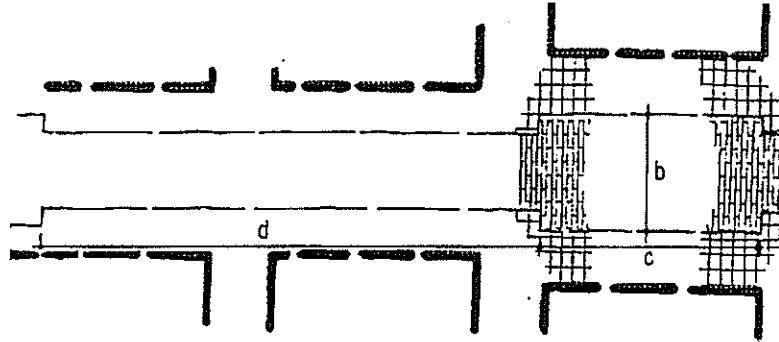
CONDITIONS FOR APPLICATION

+ erven

DIMENSIONS

- $b = 4,50$  m for truck and passenger car (sufficient for fire engine)
- $= 5,50$  m for 2 trucks (Unlikely in erven)
- $c \geq 20$  m
- $d \leq 40$  m

IMPLEMENTATION

- (See TM1)
- the thin lines symbolise an obstacle-free space for motorised traffic

ASSISTING MEASURESPOSITIVE ASPECTS

- manoeuvring space for larger vehicles

NEGATIVE ASPECTS

- relatively large area required to remain open: it is tempting to use this for parking

REMARKS:

Ref. Pages: MT6  
Literature: CROW, SARTSM, UTG1



DESCRIPTIONMEASURE PAGE

Change in horizontal alignment in erven

TM4

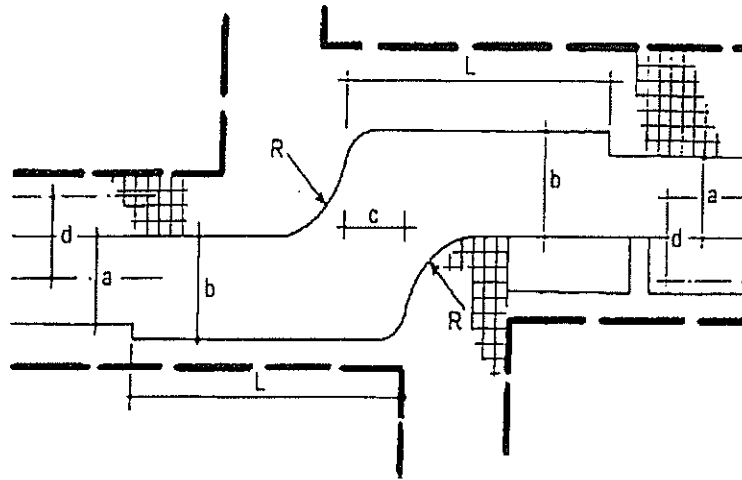
CONDITIONS FOR APPLICATION

+ erven

DIMENSIONS

• a = 3 m

b	c	d	L	R
3 m	7,5 m	1 m	-	-
3 m	5,5 m	3 m	-	3 m
3 m	5,5 m	5 m	-	5 m
3,5 m	5,5 m	7 m	22 m	6 m
4,0 m	5,5 m	9 m	24 m	6 m
4,5 m	5,5 m	11 m	26 m	6 m
5,0 m	5,5 m	13 m	28 m	6 m
5,5 m	5,5 m	15 m	30 m	6 m

IMPLEMENTATION

- See TM1
- conspicuity to be assured with vertical elements and lighting

ASSISTING MEASURES

- physical support
- visual support

POSITIVE ASPECTSNEGATIVE ASPECTS

- relatively large area required to remain open: it is tempting to use this for parking

REMARKS: Ref. Pages: MT6  
Literature: SARTSM, UTG1, CROW

DESCRIPTIONMEASURE PAGE

Vertical elements

TM5

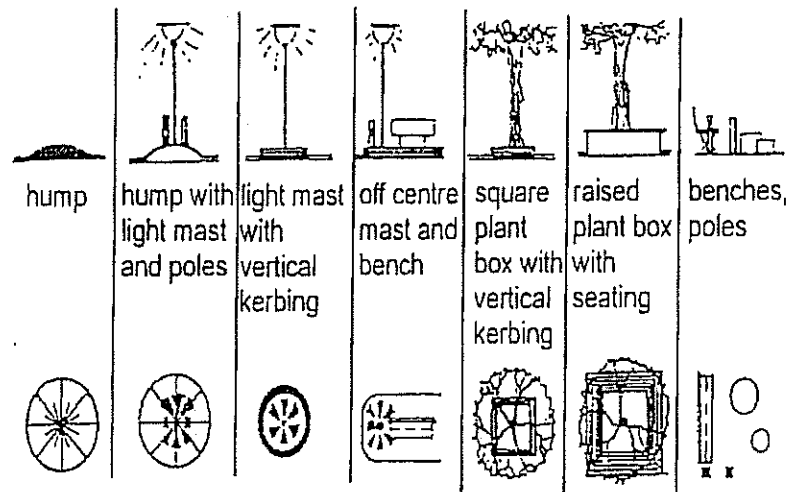
CONDITIONS FOR APPLICATIONDIMENSIONS

- (ensure adequate space for design vehicle to manoeuvre)
- high elements (thicker than light mast or tree) to be placed 1,5 to 2,0 m from traffic lane

IMPLEMENTATIONASSISTING MEASURES

- construction possible in the middle of the street, at times advisable
- conspicuity at night and during bad weather to be assured
- if need be to be protected with poles
- ensure adequate sight distance, especially between children and vehicles (sight height 0,45 m)

- speed reducing measures (hump): see TM13  
(Horizontal alignment): see TM4)

POSITIVE ASPECTSNEGATIVE ASPECTS

- enforcing character of woonerf

- humps can be problematic for vehicles with low ground clearance

REMARKS: Ref. Pages: MT6  
Literature: SARTSM, CROW, UTG1

<u>DESCRIPTION</u>	<u>MEASURE PAGE</u>
Pedestrian area with incidental co-use	TM6

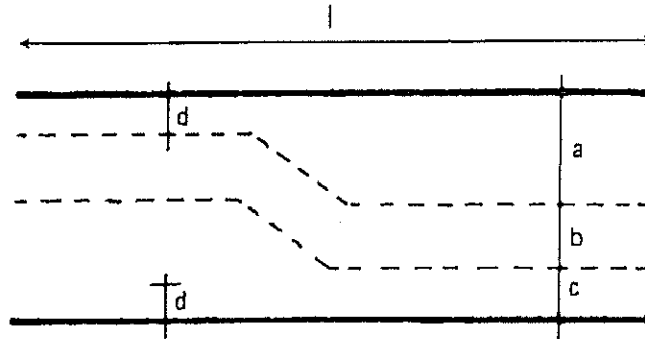

<u>CONDITIONS FOR APPLICATION</u>	<u>DIMENSIONS</u>
<ul style="list-style-type: none"> <li>• living function</li> <li>• parking in vicinity should be sufficient (alternative access possible)</li> </ul>	<ul style="list-style-type: none"> <li>• <math>l \leq</math> 40 m, if no alternative access for vehicles</li> <li>• = unlimited with alternative opening up for vehicles</li> <li>• a = variable</li> <li>• b = (strip free of obstacles) <math>\geq</math> 3 m at regular distances</li> <li>• c = variable</li> <li>• d = gable protection</li> </ul>
<u>IMPLEMENTATION</u>	<u>ASSISTING MEASURES</u>
<ul style="list-style-type: none"> <li>• surfacing on one level</li> <li>• sidewalk status to be pointed out at entry</li> <li>• preferably closed off physically</li> <li>• exemptions to be limited to emergency services, removals, etc.</li> </ul>	<ul style="list-style-type: none"> <li>• horizontal alignment: see TM4</li> <li>• facilities for the handicapped (Appendix E)</li> </ul>
<u>POSITIVE ASPECTS</u>	<u>NEGATIVE ASPECTS</u>
<ul style="list-style-type: none"> <li>- safety</li> <li>- quietness</li> </ul>	<ul style="list-style-type: none"> <li>- problems in respect of accessibility, therefore exemptions required</li> </ul>
<u>REMARKS:</u>	Ref. Pages: MT7 Literature: SARTSM, UTG1, CROW

DESCRIPTIONMEASURE PAGE

Plateau

TM7

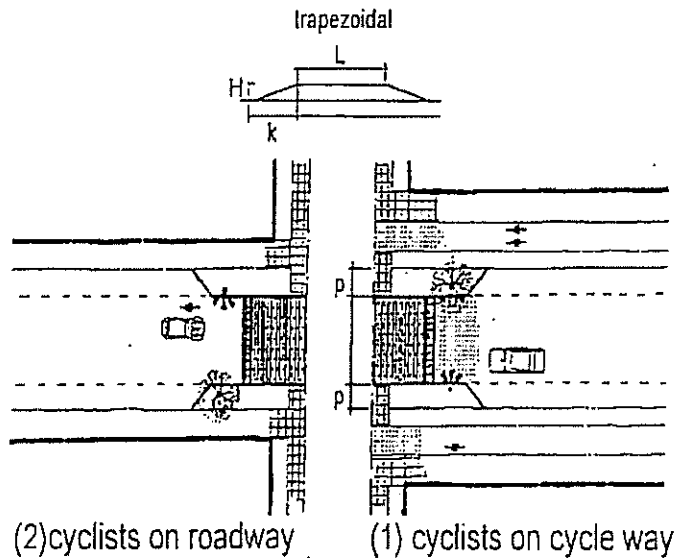
CONDITIONS FOR APPLICATION

- peak hour volumes < 600 vph
- 85th percentile speed < 50 km/h
- not on higher order roads
- not on bus and/or delivery routes
- not in cycle lane

DIMENSIONS

- $p =$  parking bay width
- $H = 0,12$  m
- $k = 19,2/(47 - p85)^*$
- distance to intersection  $\geq 8$  m
- select the design speed ( $p85$ ) so that  $V85 - P85 \leq 25$  km/h and  $18 \leq p85 \leq 40$  km/h
- $L > 3$  m

IMPLEMENTATION

- trapezium shape
- at right angles to direction of travel across the full roadway
- ensure conspicuity with vertical elements and lighting
- take care with drainage

ASSISTING MEASURES

- physical support measures: see TM15, 16, 25

POSITIVE ASPECTS

- speed reduction of maximum 25 km/h
- suitable for handicapped persons

NEGATIVE ASPECTS

- increased noise and vibration
- reduction in parking space
- could influence route choice
- with (2), disruptive for cyclists
- maintenance costs

REMARKS:

Ref. Pages: SR1, 2, 3, 4, 6, 8; Ped 5.13 (Appendix E)  
Literature: SARTSM, UTG1, CROW

Note \*: For example,  $V85 = 55$  km/h, choose  $p85 = 35$  km/h then  $k = 19,2/(47-35) = 1,6$  m  
Plateaux are used in South Africa

DESCRIPTION

Plateau with cycle paths and double sided parallel parking

MEASURE PAGE

TM8

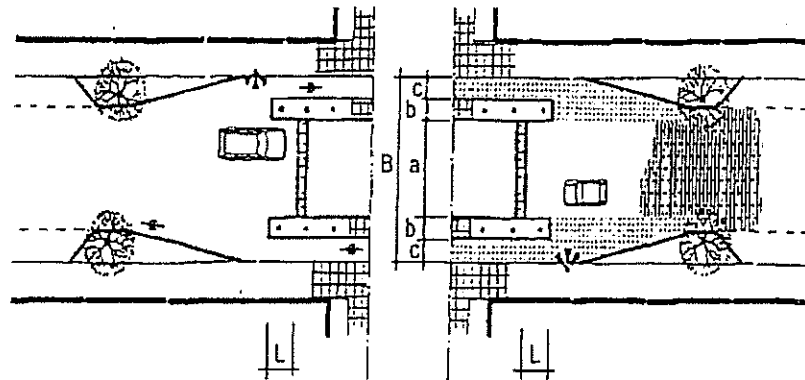
CONDITIONS FOR APPLICATION

- $B \geq 7,15$  m
- two directional traffic
- 85th percentile speed before implementation < 50 km/h
- peak hour volumes  $\leq 600$  vph
- not on higher order roads
- not on bus or emergency/delivery routes

IMPLEMENTATION

- trapezium profile
- vertical elements should be clearly recognisable through provision of adequate lighting
- marking and signing
- ensure good drainage

POSITIVE ASPECTS

- maximum speed reduction of 25 km/h
- safe and comfortable for cyclists
- can be negotiated by handicapped persons

REMARKS: Ref. Pages: PED 1, 9; SR1, 2, 5, 6, 7  
Literature: SARTSM, CROW

DIMENSIONS

- $a = 3,8 - 5$  m with two-directional traffic
- $= 2,75 - 3,25$  with two-directional traffic where narrowing to one lane is required
- $b = \geq 0,85$  m
- $c = 1,35$  m
- $L = 2 - 4$  m
- cycle path taper  $\leq 1:5$

ASSISTING MEASURES

- physical measures: see TM16
- visual support, signing and marking, greening, paving contrast, lighting

NEGATIVE ASPECTS

- cyclists are forced to weave
- increased noise and vibration
- reduced parking space
- affects route choice
- maintenance costs

DESCRIPTION

Plateau over longer length

MEASURE PAGE

TM9

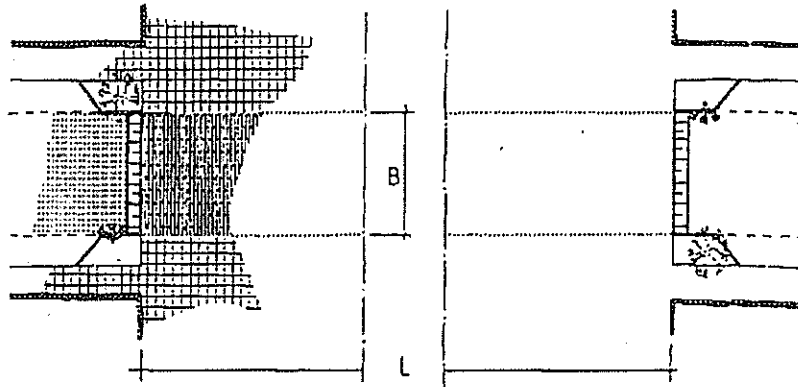
CONDITIONS FOR APPLICATION

- distributed pedestrian crossing
- peak hour volumes < 400-600 vph
- 85th percentile speed < 60 km/h (without plateaux)
- not on major order (priority) roads
- not on bus or emergency/delivery routes
- not on cycle routes
- not to be used for speed reduction by itself

IMPLEMENTATION

- ensure distinction between footway and plateau (contrasting material)
- trapezium profile
- marking and signing

POSITIVE ASPECTS

- practical integration of traffic classes
- good speed reduction
- suitable for handicapped persons
- emphasizes residential function

DIMENSIONS

- B = 4,5 - 5,0 m for two-way traffic
- = 3,25 - 3,5 for limited one-way traffic
- L = 30 - 50 m
- distance to intersection  $\geq$  8 m

ASSISTING MEASURES

- physical support: see TM19, 28
- visual support - signing and marking, greening, contrasting paving etc.

NEGATIVE ASPECTS

- could influence route choice
- increase in noise and vibration
- significant reduction in parking space
- maintenance costs

REMARKS: Ref. Pages: PED 9, 13  
Literature: SARTSM, CROW

DESCRIPTION

Raised threshold with cycle path and one-sided parking

MEASURE PAGE

TM10

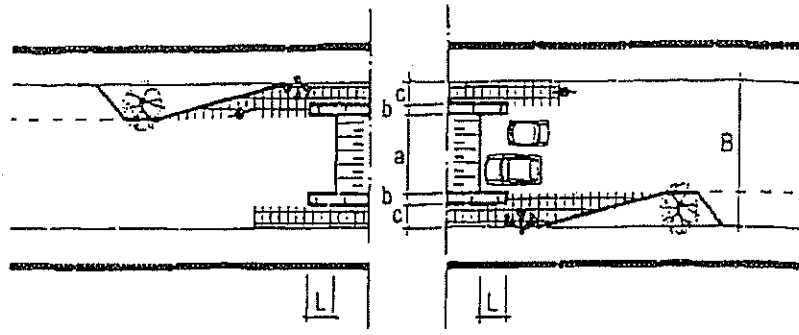
CONDITIONS FOR APPLICATION

- $B \geq 7,15$  m (6,45 m)
- two directional traffic or limited one-way traffic
- peak hour volumes < 400-600 vph
- 85th percentile speed (without threshold) < 60 km/h
- not on higher order roads
- not on bus or emergency/delivery routes

DIMENSIONS

- $a = 3,8 - 5,0$  m for two-way traffic
- $= 2,75 - 3,25$  for two-way traffic narrowed to one lane or limited one-way traffic
- $b \geq 0,85$  (0,5) m
- $c = 1,33$  m
- $L = 2 - 4$  m
- cycle path taper  $\leq 1:5$

IMPLEMENTATION

- ensure visibility of vertical elements through adequate provision of marking and lighting
- signing

ASSISTING MEASURES

- physical support: see TM16 and TM26
- visual support, signing and marking, greening, contrasting paving

POSITIVE ASPECTS

- maximum speed reduction of 25 km/h
- safe and comfortable for cyclists
- suitable for handicapped persons

NEGATIVE ASPECTS

- could influence route choice
- limited space on side islands
- increased noise and vibration
- reduced parking space
- maintenance costs

REMARKS: Ref. Pages: PED 1, 9; SR1, 2, 5, 6, 7  
Literature: SARTSM

DESCRIPTION

Flat topped hump

MEASURE PAGE

TM11

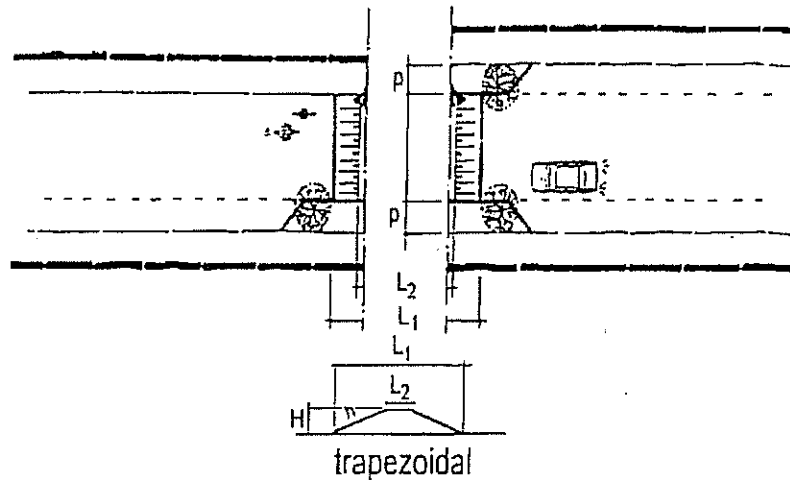
CONDITIONS FOR APPLICATION

- peak hour volumes < 400-600 vph
- 85th percentile speed < 70 km/h (without hump)
- not on major roads
- not as a pedestrian crossing by itself (Not on cycle route)

DIMENSIONS

- $p =$  parking bay width
- $L_1 =$  5 - 12,4 m
- $L_2 =$  2,4 m
- $H =$  10 - 12 cm
- $h =$  1:15 <  $h$  < 1:140
- space between humps 80-100 m
- distance to intersection  $\geq$  8 m

IMPLEMENTATION

- trapezium profile
- at right angles to roadway across the full width
- ensure visibility of vertical elements through provision of adequate signing and marking
- ensure good drainage

ASSISTING MEASURES

- Signing and marking, contrasting paving

POSITIVE ASPECTS

- the profile ensures that speeds are limited to 40 - 50 km/h, whereas at lower speeds the discomfort is minimal

NEGATIVE ASPECTS

- increased noise and vibration
- reduced parking space
- maintenance cost

REMARKS:

Ref. Pages: SR1, 2, 3, 4, 6, 8  
Literature: SARTSM, CROW

Note: Flat topped humps are common in South Africa and are often used at pedestrian crossings (pedestrian table). The length of the hump (in the direction of travel) is recommended as 4,5 m but may be increased to accommodate longer vehicles.



DESCRIPTION

Sinusoidal speed hump (30 km/h)

MEASURE PAGE

TM12

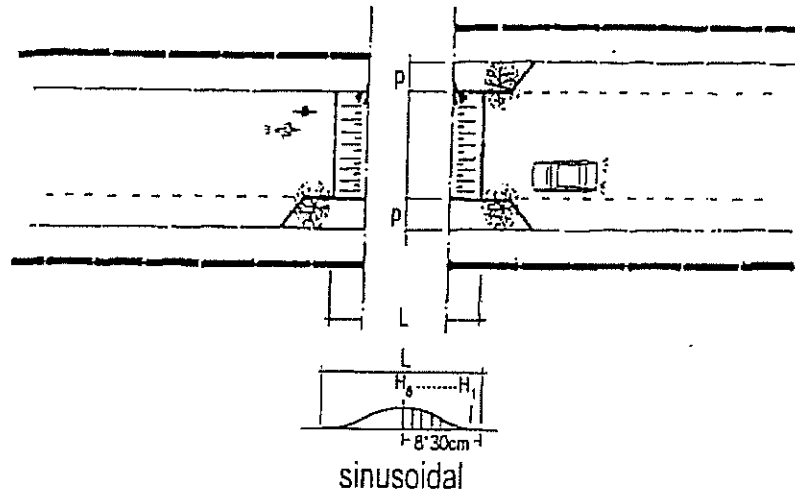
CONDITIONS FOR APPLICATION

- peak hour volumes < 400-600 vph
- 50 < 85th percentile speed < 70 km/h (without hump)
- not on major roads
- not on bus or delivery routes
- not as pedestrian crossing

DIMENSIONS

- $p =$  parking bay width
- $L = 4,8$  m
- $H_1 = 5$  mm;  $H_2 = 18$  mm;  $H_3 = 37$  mm
- $H_4 = 60$  mm;  $H_5 = 83$  mm;  $H_6 = 102$  mm
- $H_7 = 115$  mm;  $H_8 = 120$  mm
- space between humps (m) =  $10 \times$  (desired max speed between humps - 30)
- distance to intersection > 8 m

IMPLEMENTATION

- sinusoidal shape
- at right angles and across the full width of the roadway
- ensure visibility of vertical elements through adequate provision of marking and lighting (SARTSM)
- provide drainage channels at roadway edges

ASSISTING MEASURES

- Signing and marking, lighting and contrasting paving material

POSITIVE ASPECTS

- the design is such that speeds would be limited to 30 km/h over the hump

NEGATIVE ASPECTS

- difficult to construct
- increased noise and vibration
- reduced parking space
- can influence route choice
- inconvenient for cyclists
- maintenance costs

REMARKS: Ref. Pages: SR1 - 8  
Literature: SARTSM; CROW

DESCRIPTIONMEASURE PAGE

Standard speed hump

TM13

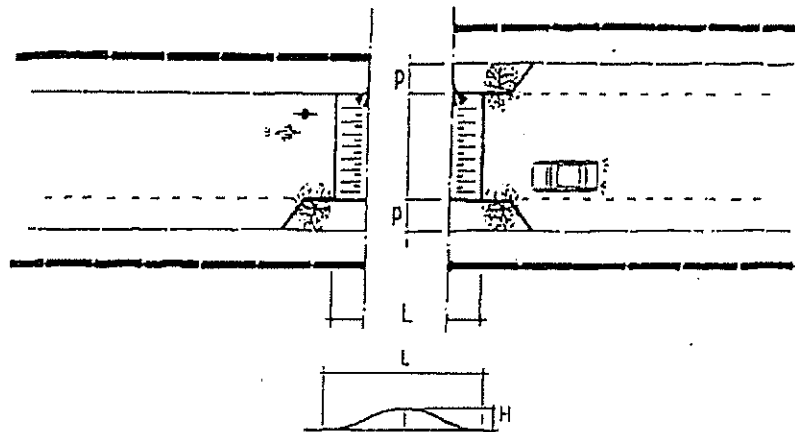
CONDITIONS FOR APPLICATION

- peak hour volumes < 400-600 vph
- $50 < 85\text{th percentile speed} < 70 \text{ km/h}$  (without hump)
- not on major roads
- not on bus or delivery routes
- not as pedestrian crossing

DIMENSIONS

- $p =$  parking bay width
- $L = 3,6 - 4,0 \text{ m}$
- $H =$  30 km/h 40 km/h 50 km/h  
100 mm 80 mm 50 mm
- space between humps (m) =  $10 \times$  (desired max speed between humps - 30)
- distance to intersection  $\geq 8 \text{ m}$

IMPLEMENTATION

- circular profile
- at right angles and across the full roadway width, leaving space at roadway edge for drainage
- ensure visibility of vertical elements through adequate provision of marking and lighting (SARTSM)

ASSISTING MEASURES

- Signing and marking, lighting and contrasting paving material

POSITIVE ASPECTS

- the design is such that speeds would be limited to the design speed over the hump

NEGATIVE ASPECTS

- increased noise and vibration
- reduced parking space
- can influence route choice
- inconvenient for cyclists
- maintenance costs

REMARKS: Ref. Pages: SR1 - 8  
Literature: SARTSM, CROW

Note: These are the most common traffic calming devices in use in South Africa.

DESCRIPTION

Speed hump with bus stop and bus sluice

MEASURE PAGE

TM14

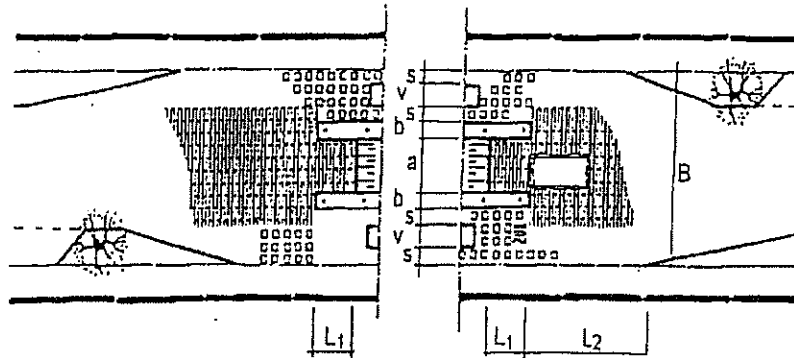
CONDITIONS FOR APPLICATION

- $B \geq 9,85$  m (9,15 m) for two-sided stop  
 $\geq 6,3$  (5,95m) for one-sided stop
- two way or restricted one-way traffic
- peak hour volumes < 400-600 vph
- 85th percentile speed (without measure) < 70 km/h
- not on major roads
- ground clearance for bus  $\geq 20$  cm
- not as pedestrian crossing

DIMENSIONS

- $a = 2,75 - 3,25$  m with two-way traffic and narrowing to one lane and with one-way limited traffic
- $b \geq 0,85$  (0,5) m
- $v = 1,3$  m with sunken sluice  
 $= 0,75 - 1,0$  m with raised sluices
- $s = 0,7 - 0,72$  m (sunken)  
 $= 0,87 - 1,0$  m (raised)
- $L_1 = 2 - 4$  m
- $L_2 = 8 - 10$  m
- entry taper 1:6
- exit taper 1:4

IMPLEMENTATION

- clearly mark bus sluice
- plateau can be used instead of hump
- pave bus stop with unfriendly material
- screen sluice off from pedestrian and cyclists
- ensure visibility of vertical elements through provision of adequate lighting and marking
- provide adequate drainage

ASSISTING MEASURESPOSITIVE ASPECTS

- maximum speed reduction of 25 km/h

NEGATIVE ASPECTS

- disruptive for buses, even through they do not cross the hump
- cyclists/motorists may collide with sluice
- maintenance costs
- reduced parking space

REMARKS:

Ref. Pages: SR1, 3, 5, 6, 7, 8  
Literature: CROW, SARTSM

DESCRIPTION

20 km/h sinusoidal speed hump

MEASURE PAGE

TM15

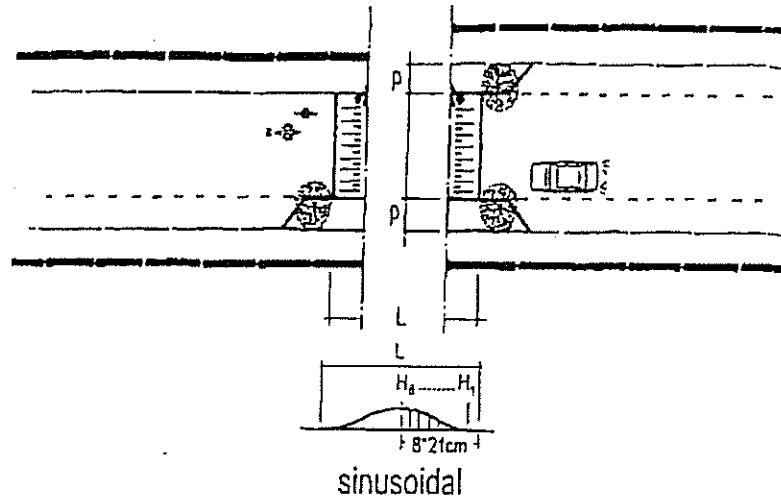
CONDITIONS FOR APPLICATION

- peak hour volumes < 400-600 vph
- 50 < 85th percentile speed < 70 km/h (without hump)
- not on major road
- not on bus or delivery route
- not as pedestrian crossing

DIMENSIONS

- $p$  = parking bay width
- $L$  = 3,36 m
- $H_1 = 5$  mm;  $H_2 = 18$  mm;  $H_3 = 37$  mm
- $H_4 = 60$  mm;  $H_5 = 83$  mm;  $H_6 = 102$  mm
- $H_7 = 115$  mm;  $H_8 = 120$  mm
- distance between humps =  $6 \times$  (desired max speed between humps - 20)
- distance to intersection  $\geq 8$  m

IMPLEMENTATION

- sinusoidal shape
- at right angles and across the full width of the roadway
- ensure visibility of vertical elements through adequate provision of marking and lighting (SARTSM)
- provide adequate drainage

ASSISTING MEASURES

- visual support - contrasting paving, signing and marking

POSITIVE ASPECTS

- ensures passage speeds of 20 km/h

NEGATIVE ASPECTS

- increased noise and vibration
- reduced parking space
- can influence route choice
- inconvenient for cyclists and motorcyclists
- maintenance costs

REMARKS: Ref. Pages: SR1, 2, 3, 4, 6, 8  
Literature: SARTSM

DESCRIPTION

Double sided choker

MEASURE PAGE

TM16

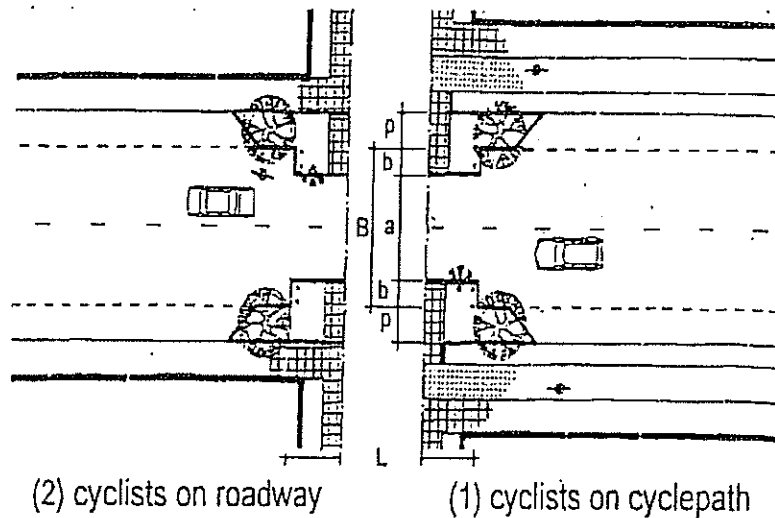
CONDITIONS FOR APPLICATION

- $B \geq 7,5 \text{ m (1)}$   
 $\geq 8,0 \text{ m (2)}$
- concentrated pedestrian crossing
- two way traffic
- with (2), only under low traffic volume and 85th percentile speeds
- not to be used in isolation for speed reduction

IMPLEMENTATION

- ensure conspicuity of vertical elements through provision of adequate lighting and marking (SARTSM)
- provide ramps from pavements for pedestrian

POSITIVE ASPECTS

- reduced crossing distance
- small reduction in speed
- excellent visibility

REMARKS:

Ref. Pages: MT6, Ped 6-8 (Appendix E)  
Literature: SARTSM

Note:

Chokers have been used with limited success in South Africa.

DIMENSIONS

- $a = 4,5 - 5,0 \text{ m (1)}$   
 $= 5,0 - 6,0 \text{ m (2)}$  or where heavy bus or heavy vehicle volumes exist
- $b \geq 1,5 \text{ m}$
- $p = \text{parking bay width}$
- $L = 5 \text{ to } 10 \text{ m}$

ASSISTING MEASURES

- physical support: see TM16, 17, 26
- visual support measures - signing and marking, lighting greening, contrasting paving

NEGATIVE ASPECTS

- reduced parking space
- with (2), difficult for cyclists

DESCRIPTION

Double sided choker with cycle paths

MEASURE PAGE

TM17

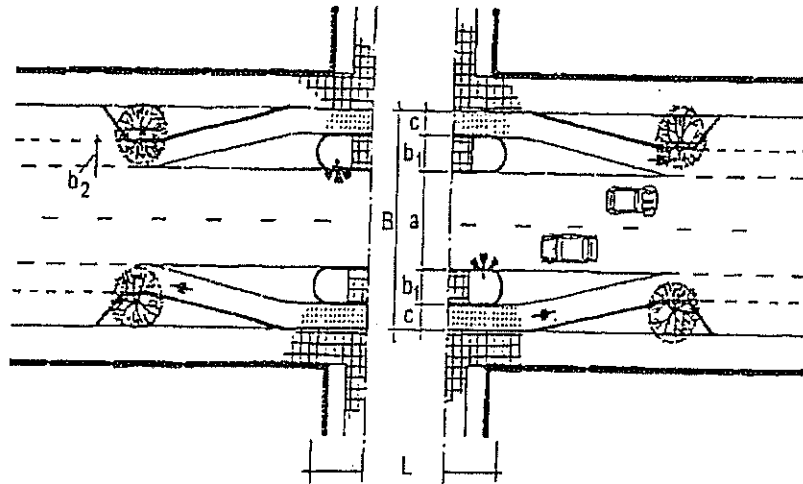
CONDITIONS FOR APPLICATION

- $B \geq 10,5$  m
- concentrated crossing
- two way traffic
- not to be used in isolation for speed reduction

DIMENSIONS

- $a = 4,5 - 5,0$  m
- $= 5,0 - 6,0$  m where bus or HGV traffic exists
- $b_1 \geq 1,5$  m
- $b_2 \geq 1,5$  m
- $c = 1,5 - 1,75$  m
- $L = 5 - 10$  m
- cycle path tapers  $\leq 1:5$

IMPLEMENTATION

- ensure conspicuity of vertical elements through provision of adequate lighting and marking for pedestrians
- provide ramps from pavements for pedestrians

ASSISTING MEASURES

- physical support: see TM17
- visual support measures - signing and marking, lighting, greening, contrasting paving

POSITIVE ASPECTS

- pedestrian refuges provided during crossing
- moderate reduction in speed
- excellent visibility
- safe for cyclists

NEGATIVE ASPECTS

- reduced parking space

REMARKS:

Ref. Pages: MT6, Ped 2,3 (Appendix E)  
 Literature: SARTSM, Pedestrian guidelines, CROW

DESCRIPTION

Long one-sided narrowing with cycle paths

MEASURE PAGE

TM30

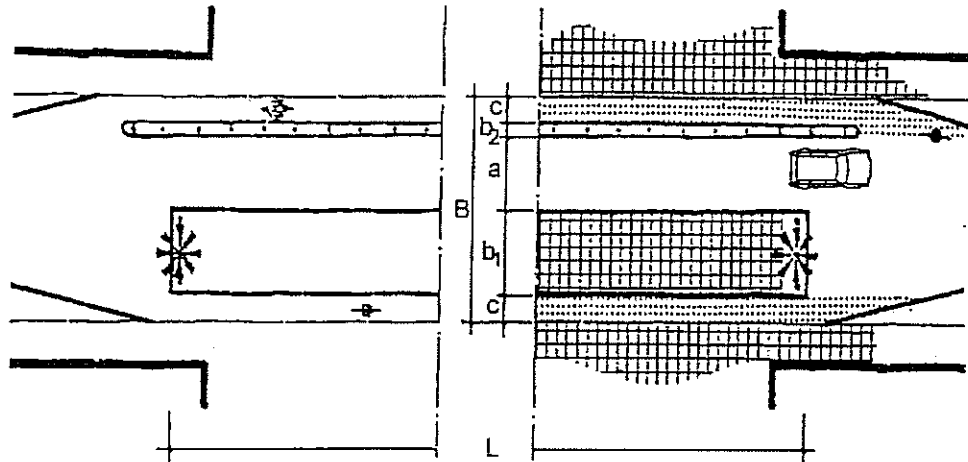
CONDITIONS FOR APPLICATION

- $B \geq 8,1$  m
- distributed crossings
- peak hour volumes < 400 vph
- 85th percentile speed < 60 km/h
- not on major roads
- even directional split with two-way traffic
- not on curves
- only as a crossing provision

DIMENSIONS

- $a = 2,75 - 3,25$  m
- $b_1 \geq 1,5$  m
- $b_2 \geq 0,5 - 0,85$  m
- $c = 1,5 - 1,75$  m
- $L < 50$  m, depending on volumes
- cycle path tapers 1:5

IMPLEMENTATION

- ensure conspicuity with vertical elements, marking and lighting
- ensure sufficient sight distance

ASSISTING MEASURESPOSITIVE ASPECTS

- reduced crossing distance with refuges
- moderate to high reduction in speed, depending on volumes
- improved (simplified) crossing situation

NEGATIVE ASPECTS

- can influence route choice
- vehicles accelerate from standstill in the narrowed section
- reduced parking space
- limited space on island (furniture)
- weaving before and after (cyclists)

REMARKS:

Ref. Pages: Ped 9 (Appendix E)  
Literature: CROW, UTG1, SARTSM

DESCRIPTION

Repeated one-sided narrowing

MEASURE PAGE

TM31

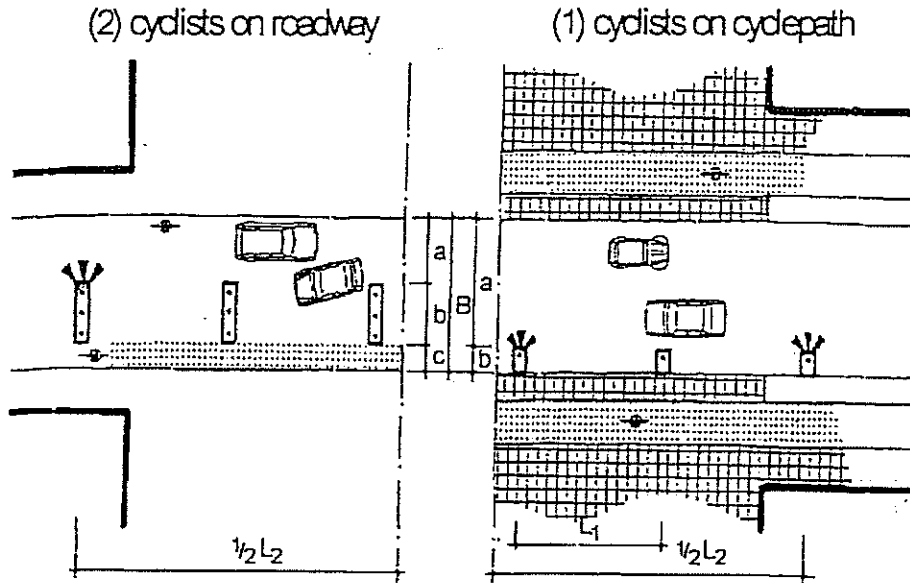
CONDITIONS FOR APPLICATION

- $B \geq 4,25$  m (1)  
 $\geq 5,6$  m (2)
- distributed crossings
- peak hour volumes < 600 vph if  $a \leq 3,25$  m and traffic is 2 way
- 85th percentile speed < 60 km/h, if  $a \leq 3,25$  m and traffic is two-way
- not on major roads

DIMENSIONS

- $a = 2,75 - 5,0$  m (depending on volumes) with two-way traffic
- $= 5,0 - 6,0$  m with high HGV and/or bus volumes
- $= 2,75 - 3,25$  m, with limited one-way traffic
- $b \geq 1,5$  m
- $c = 1,35$  m
- $L_1 = 10 - 20$  m
- $L_2 > 30$  m

IMPLEMENTATION

- ensure conspicuity with vertical elements, marking and lighting
- no parking if  $a \leq 3,25$  m and traffic is two-way

ASSISTING MEASURESPOSITIVE ASPECTS

- moderate speed reduction if  $a = 5$  m
- good speed reduction if  $a = 3$  m, depending on volumes
- reduced crossing distance

NEGATIVE ASPECTS

- limited physical protection for pedestrians
- parking between applications
- not aesthetically pleasing

REMARKS: Ref. Pages: SR1-8, Ped 9 - 16 (Appendix E)  
Literature: CROW, UTG1, SARTSM



DESCRIPTION

Two sided choker with deflected cycle paths

MEASURE PAGE

TM32

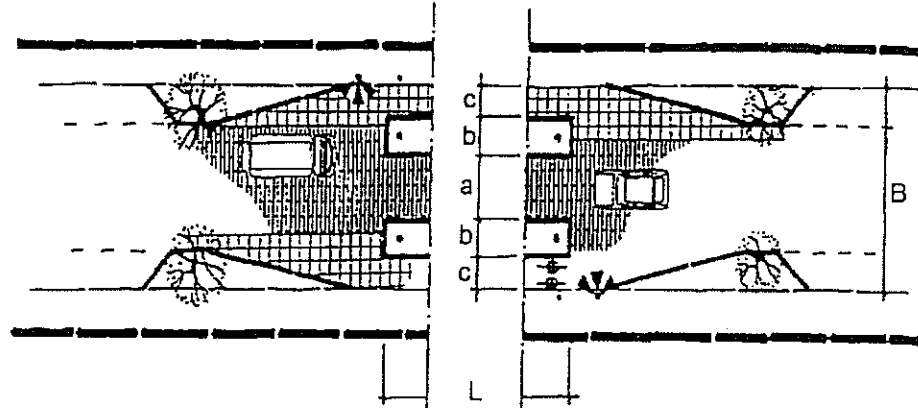
CONDITIONS FOR APPLICATION

- $B \geq 8,45$  m
- peak hour volumes < 600 vph
- 85th percentile speed < 60 km/h
- not on major roads
- even directional split with two-way traffic

DIMENSIONS

- $a = 2,75 - 3,25$  m
- $b \geq 1,5$  m
- $c = 1,35$  m
- $L = 5 - 10$  m
- cycle path tapers  $\leq 1:5$
- with repeated application ensure sufficient distance for two HGVs to pass one another

IMPLEMENTATION

- ensure conspicuity with vertical elements, marking and lighting
- ensure adequate sight distance (also on curves)
- provide ramps from pavements and islands

ASSISTING MEASURES

- physical support: see TM17
- contrasting paving, signing and marking, greening, lighting

POSITIVE ASPECTS

- reduced crossing distance with refuges
- good visibility (pedestrians)
- moderate to high reduction in speed, depending on volumes
- improved (simplified) crossing situation
- safe and comfortable for cyclists

NEGATIVE ASPECTS

- limited space on island for furniture
- could influence route choice
- reduced parking space
- cyclists have to weave before and after

REMARKS:

Ref. Pages: SR6, 8, Ped 1, 9 (Appendix E)  
Literature: SARTSM; CROW; Pedestrian Guidelines

DESCRIPTION

Central median

MEASURE PAGE

TM33

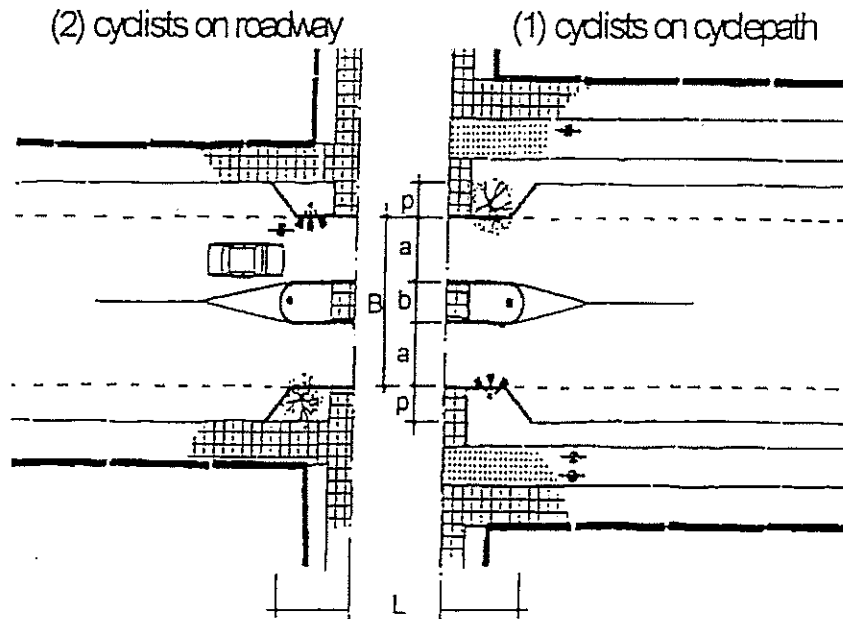
CONDITIONS FOR APPLICATION

- $B \geq 7,0$  m
- two way traffic

DIMENSIONS

- $a = 2,75 - 3,25$  m (1)
- $= 3,25 - 3,5$  m (2)
- $b \geq 1,2 - 1,5$  m
- $L = 5 - 10$  m
- $p =$  width of parking bay

IMPLEMENTATION

- preferably symmetrically placed to traffic lane
- ensure conspicuity with vertical elements, marking and lighting
- place such that crossing distance is minimised

ASSISTING MEASURES

- signing, greening, paving

POSITIVE ASPECTS

- crossing in stages
- improved crossing situation
- prevents local overtaking
- increase awareness

NEGATIVE ASPECTS

- limited space on island for furniture
- reduced parking space
- cyclists have to weave before and after

REMARKS:

Ref. Pages: SR2, 4, 6, 8, Ped 2, 3, 4, 6, 7, 8, 10, 11, 12, 14, 16 (Appendix E)  
 Literature: SARTSM; Pedestrian Guidelines; CROW, UTG1

DESCRIPTION

Median with lateral lane deflection

MEASURE PAGE

TM34

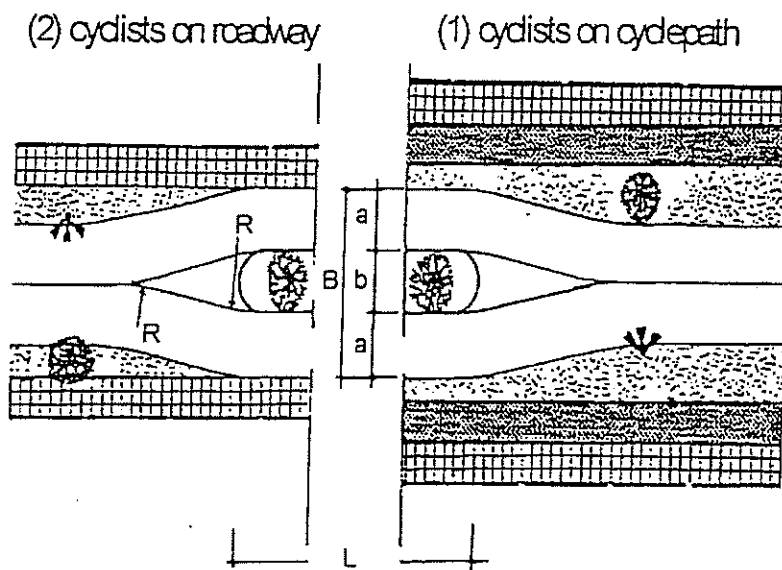
CONDITIONS FOR APPLICATION

- $B \geq 7,0 - 8,5$  m (depending 1 or 2)
- 85th percentile speed < 60 km/h
- two way traffic
- cyclists on cycle path

DIMENSIONS

- $a = 2,75 - 3,25$  m (1)
- $= 3,25 - 3,5$  m (2)
- $b \geq 3,0$  m (preferable)
- $\geq 1,5$  m (minimum)
- taper  $\leq 1:5$
- $R = 30 - 40$  m, depending design vehicle
- eventual height of plants < 60 cm

IMPLEMENTATION

- preferably symmetrically placed to traffic lane
- ensure conspicuity with vertical elements, marking and lighting
- where sufficient width exists on the median introduce greening for visual effect
- ensure good visibility

ASSISTING MEASURES

- as for TM33

POSITIVE ASPECTS

- increase awareness
- introduces discontinuity
- moderate to high speed reduction, depending on b
- improves crossing situation

NEGATIVE ASPECTS

- speed reducing effect is minimal when HGV is design vehicle
- reduced parking space
- poor sight distance from pavement
- motorists pay more attention to the deflection than to the presence of pedestrians

REMARKS:

Ref. Pages: SR2, 4, 6, 8, Ped1, 3, 5, 7, 9, 11, 13, 15 (Appendix E)  
Literature: SARTSM; Pedestrian Guidelines: CROW, UTG1

DESCRIPTION

Median island with chicane.

MEASURE PAGE

TM35

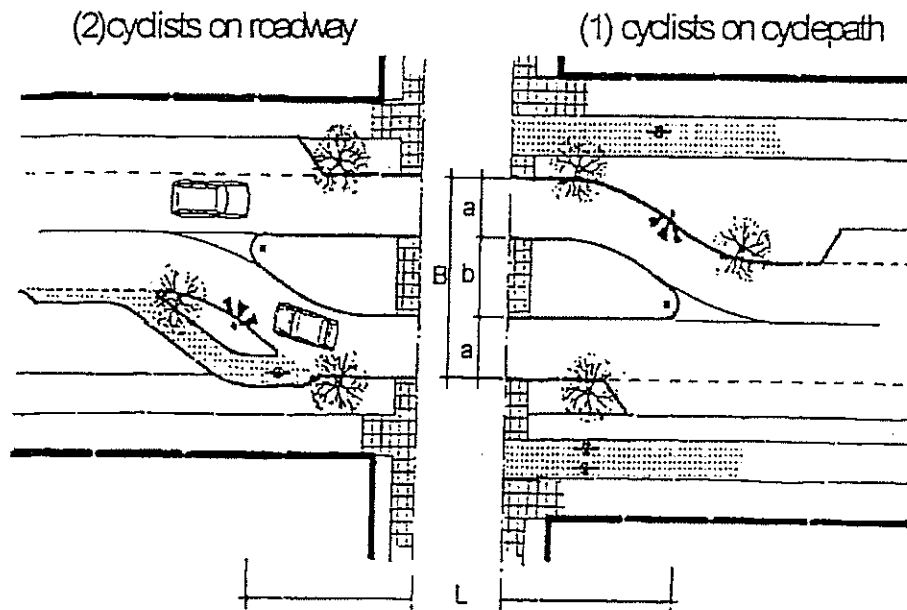
CONDITIONS FOR APPLICATION

- $B \geq 8,5$  m
- concentrated crossing
- two way traffic

DIMENSIONS

- $a = 2,75 - 3,25$  m (1)
- $= 3,25 - 3,5$  m (2)
- $b \geq 3,0$  m
- $L = 20$  m
- curve radii depending on design vehicle

IMPLEMENTATION

- nose of island symmetrical to lanes
- ensure conspicuity with vertical elements, marking and lighting
- emphasis more on pedestrian crossing than on deflection
- illustrated layout preferable to mirror image (sight distance)
- pedestrian crossing at road way level

ASSISTING MEASURES

- as for TM33

POSITIVE ASPECTS

- staged crossing
- moderate to high speed reduction, depending on b
- improves crossing situation
- introduces horizontal discontinuity

NEGATIVE ASPECTS

- motorists' attention focused on deflection
- reduced parking spaces

REMARKS:

Ref. Pages: SR6, 8, Ped 1-8 (Appendix E)  
Literature: SARTSM; Pedestrian Guidelines; CROW, UTG1

DESCRIPTION

Central median island with chicane.

MEASURE PAGE

TM36

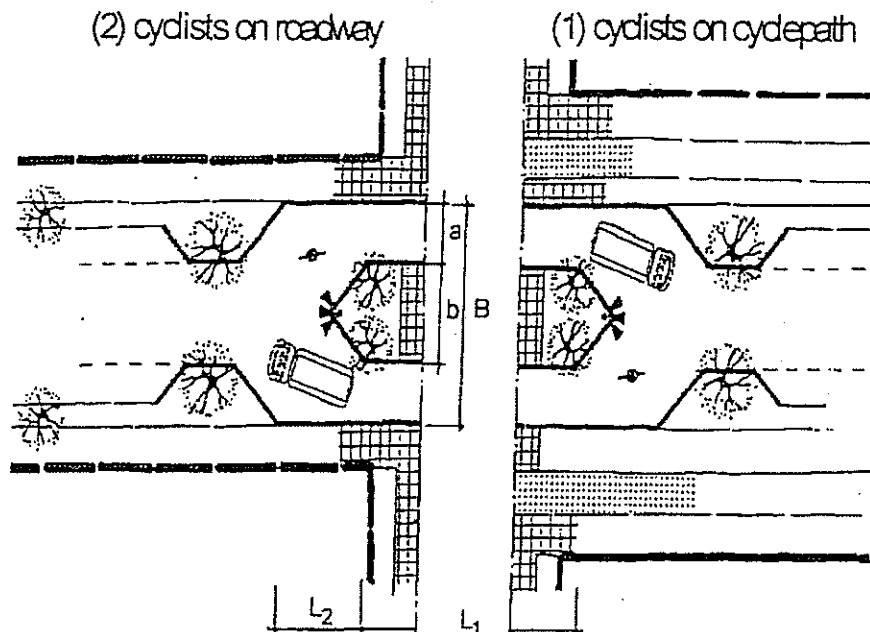
CONDITIONS FOR APPLICATION

- $B \geq 11,0$  m
- concentrated crossing
- 85th percentile speed < 60 km/h
- two way traffic
- not on cycle route (2)

DIMENSIONS

- $a = 3,25 - 3,5$  m
- $b = 4,5$  m
- $L_1 = 5 - 10$  m
- $L_2 =$  depending on design vehicle
- tapers 1:1

IMPLEMENTATION

- ensure conspicuity with vertical elements, marking and lighting
- nose of median symmetrical to lanes (centre line)
- pedestrian crossing on roadway level
- ensure good visibility

ASSISTING MEASURES

- as for TM33

POSITIVE ASPECTS

- staged crossing
- moderate to high speed reduction (depending design vehicle)
- improves crossing situation

NEGATIVE ASPECTS

- reduced parking spaces
- narrow for cyclists (2)

REMARKS:

Ref. Pages: SR8, Ped1, 3, 5, 7 (Appendix E)  
Literature: SARTSM; Pedestrian Guidelines; CROW, UTG1

Note : These have been applied with limited success in South Africa

DESCRIPTION

Chicane with one-sided parking

MEASURE PAGE

TM37

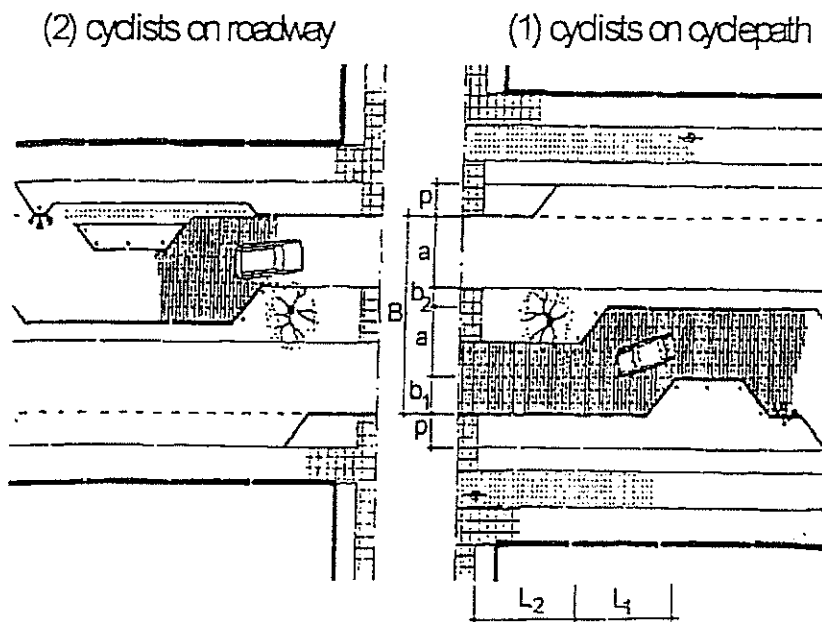
CONDITIONS FOR APPLICATION

- $B \geq 9,5$  m
- concentrated crossing
- 85th percentile speed < 60 km/h
- not on major roads
- two way traffic

DIMENSIONS

- $a = 3,25 - 3,5$  m
- $b_1 \geq 2,0$  m
- $b_2 \geq 1,0$  m
- $p =$  width of parking bay
- $L_1 =$  depending on design vehicle
- $L_2 = 5$  m

IMPLEMENTATION

- ensure conspicuity with vertical elements, marking and lighting
- vertical elements on island
- lower median for pedestrian crossing

ASSISTING MEASURES

- as for TM33

POSITIVE ASPECTS

- moderate to high speed reduction (depending design vehicle)

NEGATIVE ASPECTS

- reduced parking spaces

REMARKS:

Ref. Pages: SR6, 8, Ped 1, 3, 5, 7, 9, 11, 13, 15 (Appendix E)  
Literature: SARTSM; CROW, UTG1

DESCRIPTION

Median with bus stop

MEASURE PAGE

TM38

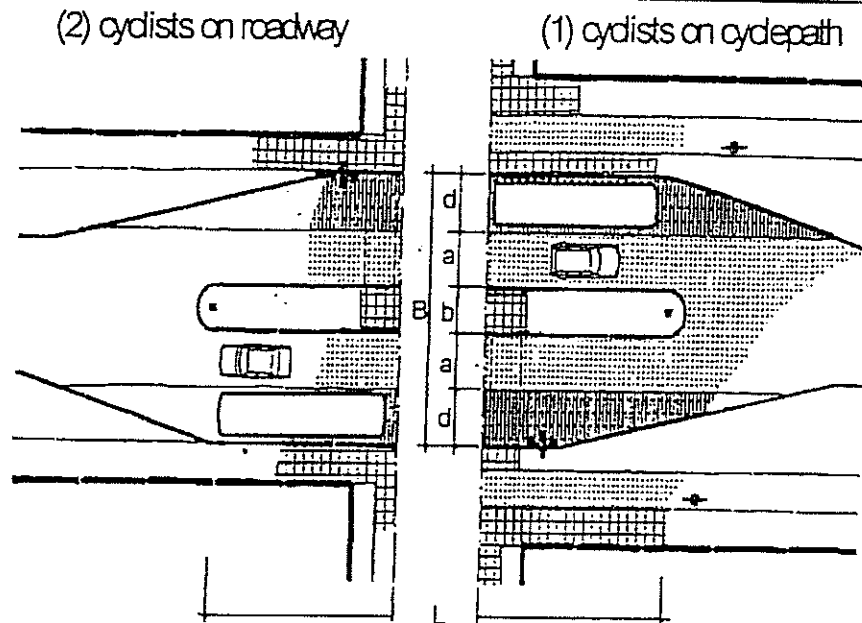
CONDITIONS FOR APPLICATION

- $B \geq 12,5$  m
- concentrated crossing
- two way traffic
- only as pedestrian crossing

DIMENSIONS

- $a = 2,75 - 3,25$  m (1)
- $= 3,25 - 3,5$  m (2)
- $b \geq 1,5$  m
- $d = 2,75 - 3,0$  m
- $L = 26$  m
- entry taper for bus stop 1:6
- exit taper for bus stop 1:4

IMPLEMENTATION

- median centrally situated between lanes
- ensure conspicuity with vertical elements, marking and lighting
- use contrasting materials for roadway, bus stop and pedestrian crossing, marking between lay bye and roadway (SARTSM)
- barriers on median to prevent pedestrians crossing at would along the length

ASSISTING MEASURES

- as for TM33

POSITIVE ASPECTSNEGATIVE ASPECTS

- relatively long crossing distance
- limited space for furniture on island
- reduced parking spaces

REMARKS: Ref. Pages: Ped 3, 7, 8 (Appendix E)  
Literature: SARTSM; CROW, UTG1

DESCRIPTION

Width restriction by means of a long central reserve

MEASURE PAGE

TM39

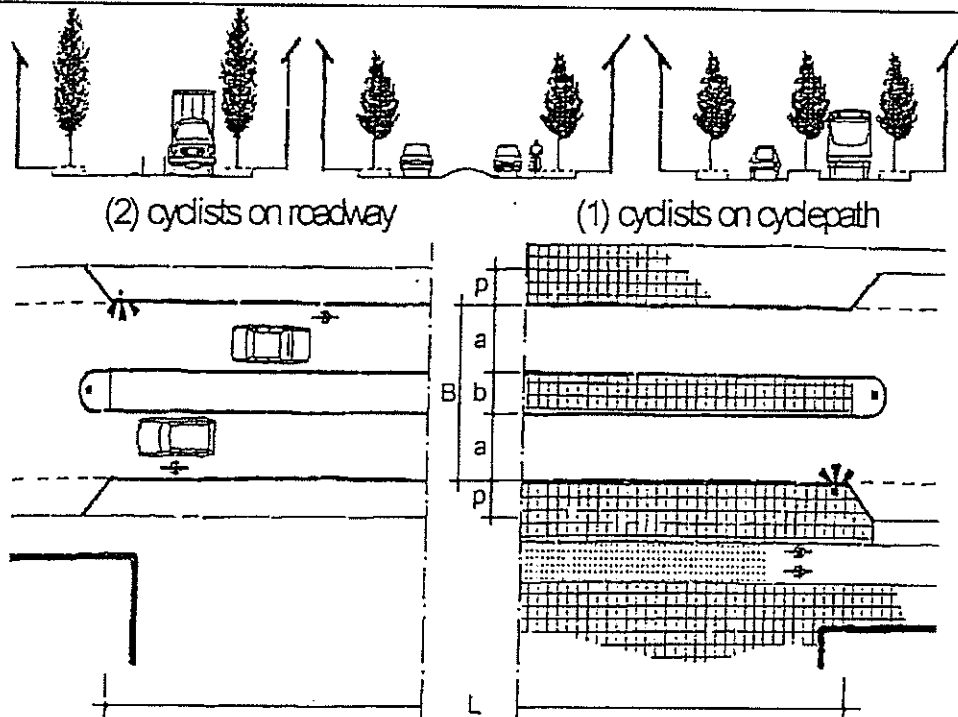
CONDITIONS FOR APPLICATION

- $B \geq 7,0$  m
- distributed crossing
- two way traffic
- only as pedestrian crossing

DIMENSIONS

- $a = 2,75 - 3,25$  m (1)
- $= 3,25 - 3,5$  m (2)
- $b \geq 1,5$  m
- $p =$  width of parking bay
- $L =$  dependent on volumes (can be longer as volumes decrease)

IMPLEMENTATION

- ensure conspicuity with vertical elements, marking and lighting
- preferably symmetrical to lanes

ASSISTING MEASURES

- physical: see TM65, SM1
- as for TM33

POSITIVE ASPECTS

- staged crossing
- improved crossing situation
- moderate speed reduction, (depending on design vehicle)
- no passing opportunities

NEGATIVE ASPECTS

- reduction in parking spaces
- possible increase in speed due to predictability of situation, especially with wider lanes
- emergency vehicles cannot pass if lane is blocked

REMARKS:

Ref. Pages: SR2, 4, 6, 8, Ped 9-16; (Appendix E)  
 Literature: SARTSM; UTG1; CROW



DESCRIPTION

Median with one-sided parking  
(small chicane)

MEASURE PAGE

TM40

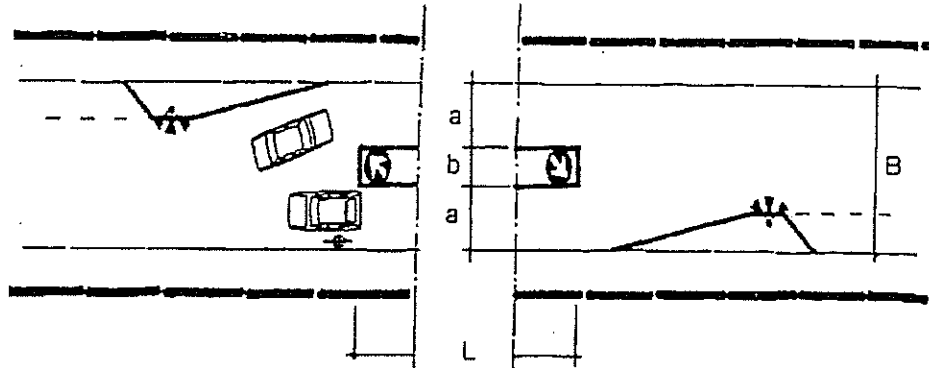
CONDITIONS FOR APPLICATION

- $B \geq 8,0$  m
- 85th percentile speed < 60 km/h
- two way traffic
- only as pedestrian crossing

DIMENSIONS

- $a = 3,25 - 3,5$  m
- $b \geq 1,5$  m
- $L = 5 - 10$  m
- taper on deflection islands  $\leq 1:5$

IMPLEMENTATION

- median centrally placed on roadway
- ensure conspicuity with vertical elements, marking and lighting
- pedestrian crossing on roadway level

ASSISTING MEASURES

- as for TM33

POSITIVE ASPECTS

- staged crossing
- improved crossing situation
- moderate speed reduction

NEGATIVE ASPECTS

- limited space on island for furniture
- reduced parking space

REMARKS:

Ref. Pages: SR2, 4, Ped 1, 3, 5, 7, 9, 11, 13, 15 (Appendix E)  
Literature: SARTSM; CROW; UTG1, Pedestrian Guidelines

DESCRIPTION

Semi-chicane with one-sided parking

MEASURE PAGE

TM41

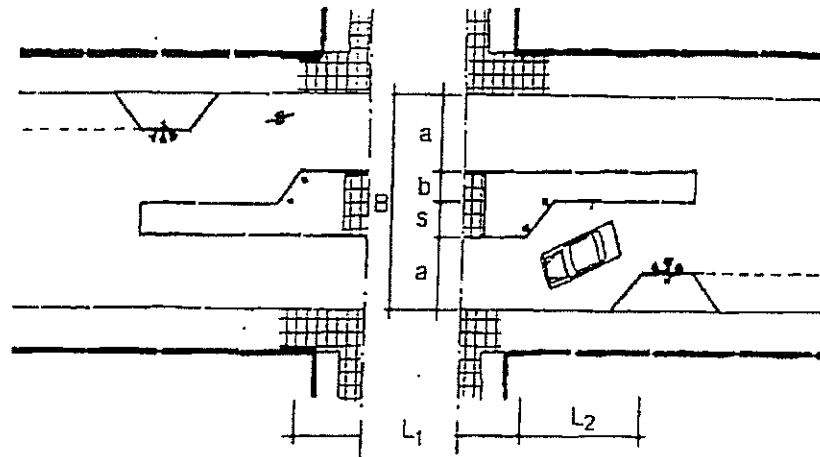
CONDITIONS FOR APPLICATION

- $B \geq 9,8$  m
- 85th percentile speed < 60 km/h
- two way traffic
- not on major roads
- not on cycle routes

DIMENSIONS

- $a = 3,25 - 3,5$  m
- $b \geq 1,5$  m
- $s =$  width parking bay
- $L_1 = 5 - 10$  m
- $L_2 =$  depending on design vehicle
- taper = 1:1

IMPLEMENTATION

- ensure conspicuity with vertical elements, marking and lighting
- pedestrian crossing on roadway level
- ensure good visibility

ASSISTING MEASURES

- as for TM33

POSITIVE ASPECTS

- staged crossing
- improved crossing situation
- moderate speed reduction

NEGATIVE ASPECTS

- narrow for cyclists
- reduced parking space

REMARKS:

Ref. Pages: SR6, 8, Ped 1, 3, 5, 7, 9, 11, 13, 15 (Appendix E)  
Literature: SARTSM; Pedestrian Guidelines; UTG1

DESCRIPTION

Lane deflection

MEASURE PAGE

TM42

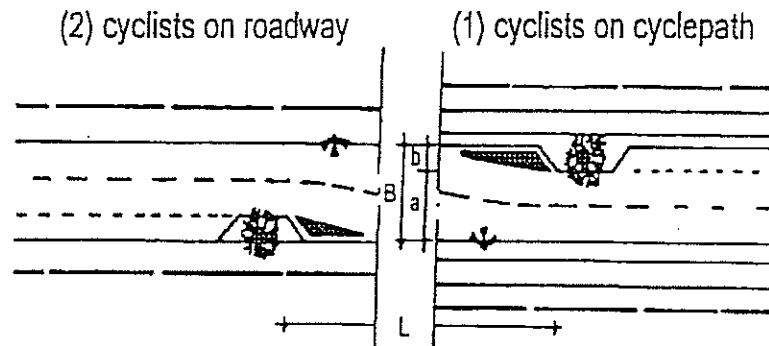
CONDITIONS FOR APPLICATION

- straight roads
- one sided parking
- $B \geq 5,0$  m
- peak hour volumes < 600 vph if  $a < 5,0$  m and traffic is two-way
- 85th percentile speed < 60 km/h
- not on major roads
- not on cycle routes (2)

DIMENSIONS

- $a = 3,25 - 5,5$  m (depending on volumes) with two-way traffic
- $= 5,0 - 6,5$  m with HGV and/or bus traffic
- $= 3,25 - 3,5$  m, with one-way traffic (1) or limited one-way traffic (2)
- $b =$  width of parking bay
- $L =$  depending on design vehicle
- taper of deflection island 1:1

IMPLEMENTATION

- ensure conspicuity with vertical elements, marking and lighting
- pedestrian crossing on roadway level
- ensure good visibility

ASSISTING MEASURES

- physical support: see TM17

POSITIVE ASPECTS

- moderate speed reduction
- introduces discontinuity

NEGATIVE ASPECTS

- narrow for cyclists
- reduced parking space

REMARKS:

Ref. Pages: SR3, 4  
Literature: CROW; UTG1; SARTSM

Note: This measure has been applied to a limited extent in South Africa.

DESCRIPTION

Chicane.

MEASURE PAGE

TM43

(2) cyclists on roadway

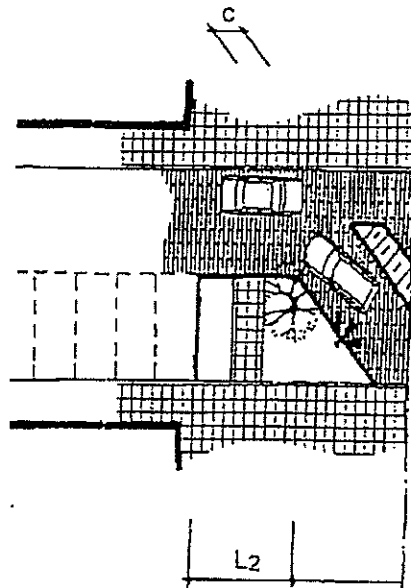

(1) cyclists on cyclepath

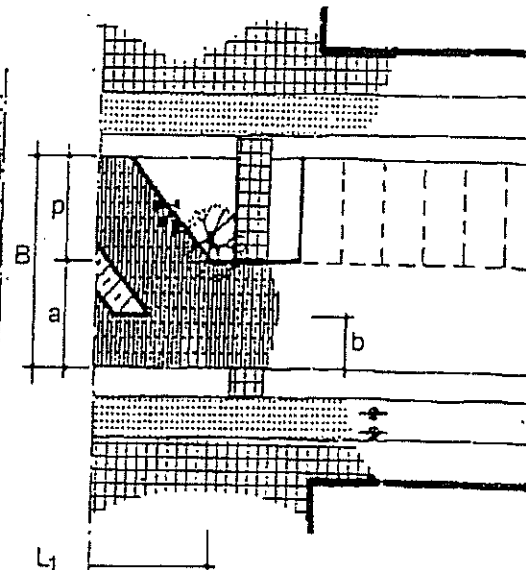
CONDITIONS FOR APPLICATION

- $B \geq 9,5$  m
- peak hour volumes < 600 vph
- 85th percentile speed < 60 km/h
- not on major roads
- two way traffic
- not on cycle route with high parking turnover (2)

DIMENSIONS

- $a \geq 5,0 - 6,0$  m (depending on design vehicle)
- $b = 2,5$  m
- $c = 1,5$  m
- $p = 4,5$  m
- $L_1 =$  depending on design vehicle
- $L_2 = 5 - 6$  m
- tapers 1:1
- medium cross section, circle segment with maximum height of 0,12 m

IMPLEMENTATION

- ensure conspicuity with vertical elements, marking and lighting
- raised islands with circular profiles marked in white
- provide adequate sight distance
- parking bays (refer to parking standards)

ASSISTING MEASURES

- physical support: see TM17
- as for TM33

POSITIVE ASPECTS

- high speed reduction
- discontinuity in horizontal alignment

NEGATIVE ASPECTS

- reduction in parking spaces
- poor visibility from parking spaces
- without island, speed reduction is low

REMARKS:

Ref. Pages: SR5-8, Ped 1, 5, 9, 13 (Appendix E)  
Literature: SARTSM; UTG1, CROW

Note: Chicanes have been applied to a limited extent in South Africa.

DESCRIPTION

Short width restriction (choker)

MEASURE PAGE

TM44

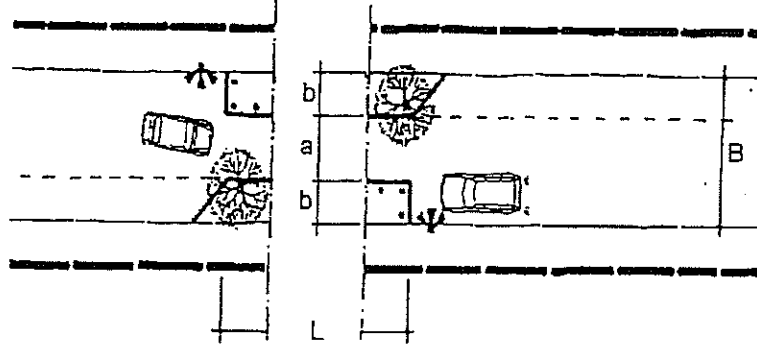
CONDITIONS FOR APPLICATION

- $B \geq 6,85$  m
- peak hour volumes < 600 vph
- 85th percentile speed < 60 km/h
- not on major roads
- not on cycle route
- [even directional split in traffic volumes for two-way traffic]

DIMENSIONS

- $a = 3,25 - 3,5$  m
- $b \geq$  width of parking bay
- $L = 5 - 10$  m
- with repeated use, ensure sufficient distance between measures for two HGVs to pass one another

IMPLEMENTATION

- ensure conspicuity with vertical elements, marking and lighting
- provide ramps from pavements
- ensure good sight distance

ASSISTING MEASURES

- physical support: see TM17
- as for TM33

POSITIVE ASPECTS

- shortened crossing distance
- improved crossing situation
- moderate to high speed reduction, depending on volumes

NEGATIVE ASPECTS

- possible increase in speed on approach to choker
- could influence route choice
- narrow for cyclists
- reduction in parking
- parallel parking results in virtually no speed reduction

REMARKS: Ref. Pages: SR4, Ped 1, 9 (Appendix E)  
Literature: SARTSM, UTG1, CROW

DESCRIPTION

Change of direction with narrowing in roadway  
combined with cycle ways

MEASURE PAGE

TM45

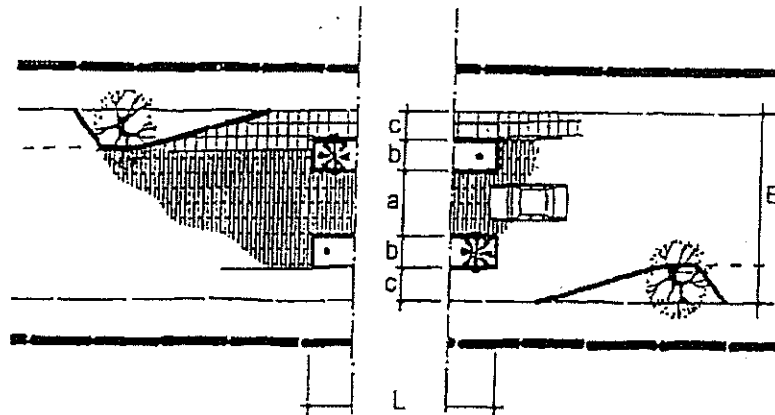
CONDITIONS FOR APPLICATION

- $B \geq 8,45$  m
- peak hour volumes < 600 vph
- 85th percentile speed < 60 km/h
- not on major roads
- two way traffic with an even directional split

DIMENSIONS

- $a = 2,75 - 3,25$  m
- $b \geq 1,50$  m
- $c = 1,35$  m
- $L = 5 - 10$  m
- taper cycle way  $\leq 1:5$
- if repeated on the road section, leave enough space for HGVs to pass one another

IMPLEMENTATION

- ensure conspicuity with vertical elements, and adequate lighting
- provide adequate sight distance
- at pedestrian crossing, lower kerb or construct ramps
- cycle ways to be paved in contrasting colour
- sketched construction has preference over the mirror image

ASSISTING MEASURES

- physical support: see TM7

POSITIVE ASPECTS

- shorter crossing and can be crossed in two stages
- moderate to good speed reduction, depending on volumes
- very good visibility for pedestrians
- easier to cross street
- safe and comfortable way to separate cyclists from rest of traffic - cyclists do not have to filter in after passing obstructions

NEGATIVE ASPECTS

- little space on medians
- could influence route choice
- possible acceleration when seeing oncoming traffic
- possible blocking of cycle ways by waiting vehicles

REMARKS: Ref. Pages: SR2, 4, 6, Ped 1, 9 (Appendix E)  
Literature: SARTSM; CROW, UTG1

DESCRIPTION

Double bayonet formed by narrowing one side of road

MEASURE PAGE

TM46

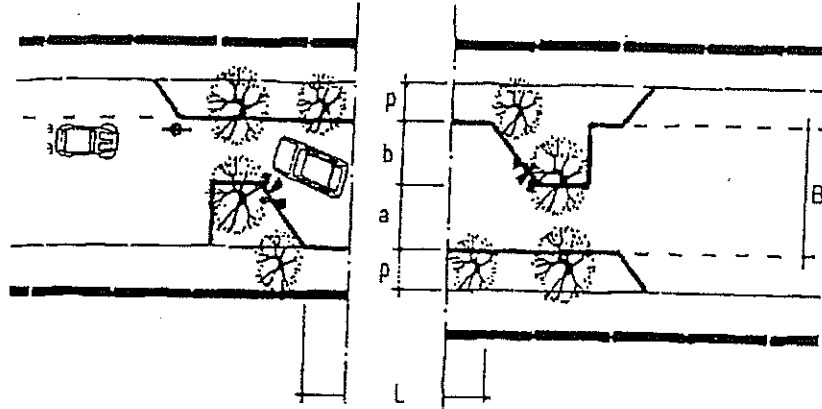
CONDITIONS FOR APPLICATION

- $B \geq 4,75$  m
- peak hour volume < 400 vph
- 85th percentile speed < 60 km/h
- not on major roads
- not on cycle route
- not on bus- or supply/provisioning route

DIMENSIONS

- $a = 3,25 - 3,50$  m
- $b \geq 1,50$  m
- $p =$  wide parking area
- $L =$  depends on manoeuvrability of design vehicle

IMPLEMENTATION

- ensure conspicuity with vertical elements, and provide adequate lighting
- provide adequate sight distances
- the layout as shown above is preferable to its mirror image: see TM46

ASSISTING MEASURES

- as for TM33

POSITIVE ASPECTS

- good speed reduction
- shorter crossings distance at narrowed area

NEGATIVE ASPECTS

- could influence route choice
- crowding of cyclists
- decrease in parking space: 3 to 4 on each side

REMARKS: Ref. Pages: SR3, 4, 7, 8  
Literature: SARTSM; UTG1; CROW

DESCRIPTION

Double bayonet formed by narrowing one side of roadway, combined with cycle ways

MEASURE PAGE

TM47

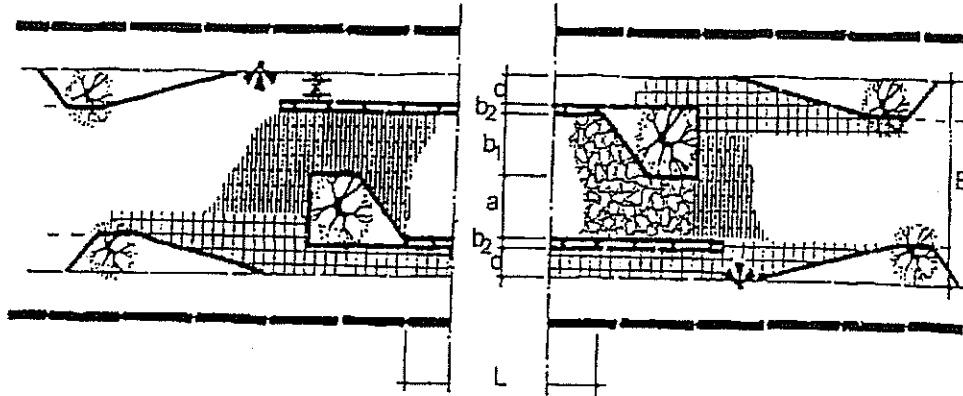
CONDITIONS FOR APPLICATION

- $B \geq 7,95$  m
- Peak hour volumes < 400 vph
- 85th percentile speed < 60 km/h
- not on major roads
- not on bus- and supply/provisioning route

DIMENSIONS

- $a = 3,25 - 3,50$  m
- $b_1 \geq 1,50$  m
- $b_2 \geq 0,50$  m
- $c = 1,35$  m
- $L =$  depends on manoeuvrability of design vehicle
- taper cycle ways  $\leq 1:5$

IMPLEMENTATION

- ensure conspicuity with vertical elements, and provide adequate lighting
- provide adequate sight distances
- the layout as shown above is preferable to its mirror image: see TM46

ASSISTING MEASURES

- as for TM33

POSITIVE ASPECTS

- good speed reduction
- shorter crossings distance and can be crossed in two stages
- safe and comfortable way to separate cyclists from rest of traffic

NEGATIVE ASPECTS

- could influence route choice
- cyclists have to filter into traffic after passing obstructions
- decrease in parking space: about 7 on each side

REMARKS:

Ref. Pages: SR1, 2, 5, 6  
Literature: SARTSM; UTG1; CROW



DESCRIPTION

Double bayonet formed by narrowing on one side on roadway, combined with cycle ways and provision for bus

MEASURE PAGE

TM48

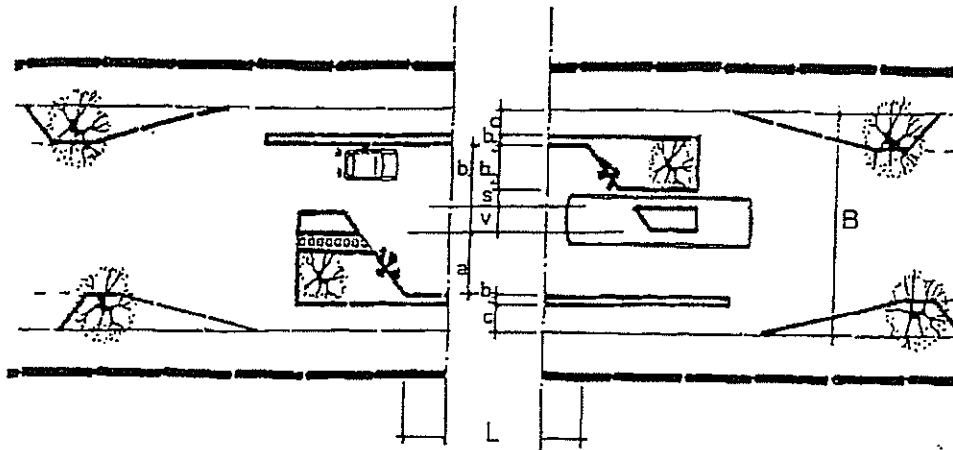
CONDITIONS FOR APPLICATION

- $B \geq 10,70$  m
- Peak hour volumes < 400 vph
- 85th percentile speed < 60 km/h
- not on major roads
- bottom clearance bus  $\geq 20$  cm

DIMENSIONS

- $a = 2,75 - 3,25$  m
- $b_1 \geq 4,25$  m
- $b_2 \geq 2,38$  m
- $b_3 \geq 0,50$  m
- $c = 1,35$  m
- $s = 0,87$  m
- $v = 1,00 (0,75)$  m
- $L =$  depends on manoeuvrability of design vehicle
- taper cycle ways  $\leq 1:5$
- height of bus gateway 15 cm

IMPLEMENTATION

- ensure conspicuity with vertical elements, and provide adequate lighting
- ensure adequate sight distances
- do not use sunken bus gateway construction
- bus lane paved in contrasting material
- the layout as shown above is preferable to its mirror image: see TM46

ASSISTING MEASURES

- visual support measures: as for TM33

POSITIVE ASPECTS

- good speed reduction
- safe and comfortable way to separate cyclists from rest of traffic
- trucks can use buslane

NEGATIVE ASPECTS

- could influence route choice
- cyclists have to filter into traffic after passing obstructions
- vehicles driving behind bus should be able to pass without danger
- decrease in parking space: about 7 on each side

REMARKS: Ref. Pages: SR5, 6, 7, 8  
Literature: SARTSM; UTG1; CROW

DESCRIPTION

Double bayonet and change of direction/diversion  
combined with cycle ways

MEASURE PAGE

TM49

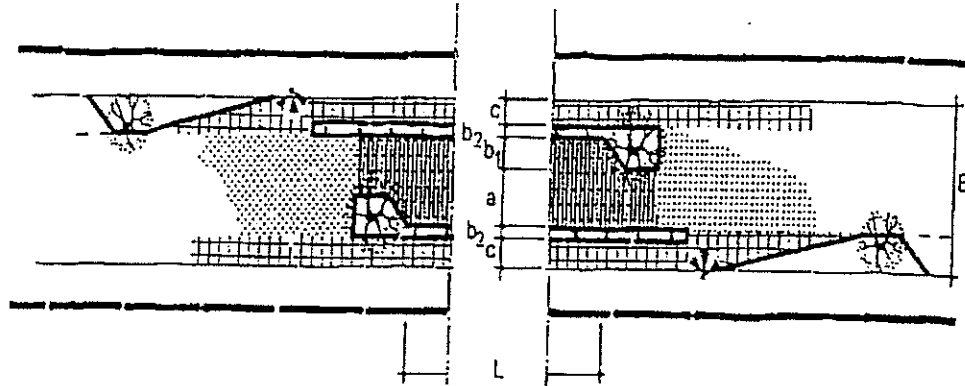
CONDITIONS FOR APPLICATION

- $B \geq 7,95$  m
- Peak hour volumes < 400 vph
- 85th percentile speed < 60 km/h
- not on major roads
- not on bus- and/or supply/provisioning road, route

DIMENSIONS

- $a = 3,25 - 3,5$  m
- $b_1 \geq 1,5$  m
- $b_2 \geq 0,5$  m
- $c = 1,35$  m
- $L =$  depends on manoeuvrability of design vehicle
- gradient of cycle ways  $\leq 1:5$

IMPLEMENTATION

- ensure conspicuity by vertical elements, and provide adequate lighting
- ensure adequate sight distances
- the layout as shown above is preferable to its mirror image: see TM46

ASSISTING MEASURES

- visual support measures: as for TM33

POSITIVE ASPECTS

- good speed reduction
- shorter crossing distance and can be crossed in two stages
- safe and comfortable way to separate cyclists from rest of traffic

NEGATIVE ASPECTS

- could influence route choice
- decrease in parking space: about 7 on each side

REMARKS:

Ref. Pages: SR1, 2, 6  
Literature: SARTSM; UTG1; CROW

DESCRIPTION

Change of direction/diversion

MEASURE PAGE

TM50

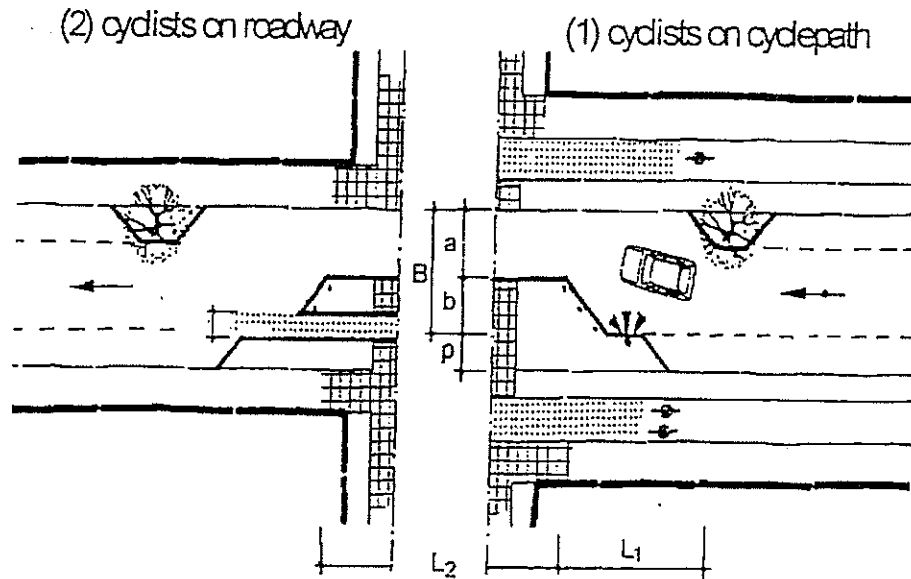
CONDITIONS FOR APPLICATION

- $B \geq 4,25$  m
- 85th percentile speed < 60 km/h
- not on major roads
- one way traffic; (1) also when cyclists come from opposite direction

DIMENSIONS

- $a = 3,25 - 3,5$  m
- $b \geq 1,5$  m
- $c = 1,35$  m
- $p =$  width parking area
- $L_1 =$  depends on manoeuvrability of design vehicle
- gradient 1:1
- $L_2 = 5 - 10$  m
- if repeated on road section, leave enough space for opposing HGVs to be able to pass

IMPLEMENTATION

- ensure conspicuity with vertical elements, and provide adequate lighting
- at pedestrian crossing, lower kerb or construct a ramp
- (2) can be used without provision for cyclists, but not when on a cycle route
- if B is too small or where b should be enlarged, construct cycle ways instead of parking space

ASSISTING MEASURES

- physical support: see TM7
- visual support measures: as for TM33

POSITIVE ASPECTS

- moderated to good speed reduction
- very visible

NEGATIVE ASPECTS

- total decrease in parking space: 9 - 11

REMARKS: Ref. Pages: SR1, Ped 1,3,5,7,13 (Appendix E)  
Literature: SARTSM; UTG1; CROW

DESCRIPTION

Roadway deviation

MEASURE PAGE

TM51

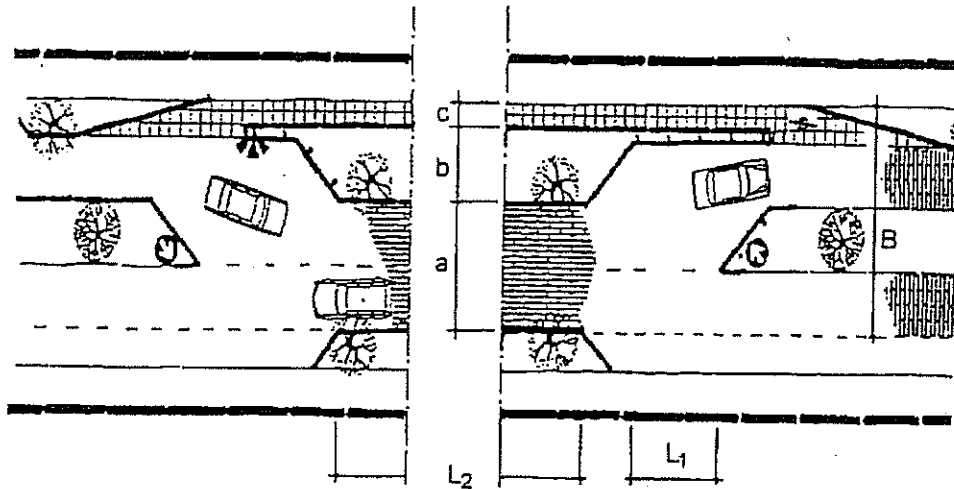
CONDITIONS FOR APPLICATION

- $B \geq 7,85$  m
- peak hour volumes < 600 ph
- 85th percentile speed < 60 km/h
- two way traffic

DIMENSIONS

- $a = 4,5 - 5$  m
- $= 5 - 6$  m  
where there is bus and/or truck traffic
- $b \geq 2$  m
- $c = 1,35$  m
- $L_1 =$  depends on manoeuvrability of design vehicle
- $L_2 = 5 - 10$  m
- taper cycle ways  $\leq 1:5$
- taper roadway deviation 1:1

IMPLEMENTATION

- ensure conspicuity with vertical elements, and provide adequate lighting
- where the median is interrupted, width of roadway should be indicated
- construct deviations on alternate lanes, first on one direction, then on the opposite direction

ASSISTING MEASURESNEGATIVE ASPECTSPOSITIVE ASPECTS

- good speed reduction in lane where deviation is constructed
- visual relief without impeding sight distance

- cyclists have to filter into traffic after passing deviation

REMARKS: Ref. Pages: SR6  
Literature: CROW; UTG1, SARTSM

DESCRIPTION

Slanted narrowing of roadway

MEASURE PAGE

TM52

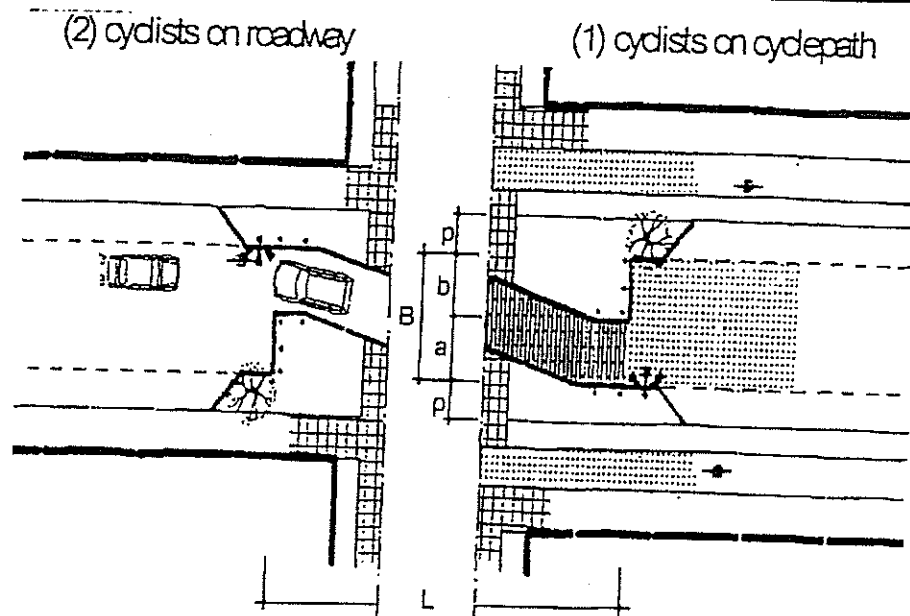
CONDITIONS FOR APPLICATION

- $B \geq 4,42$  m
- Peak hour volumes < 600 vph
- 85th percentile speed < 60 km/h
- not on major roads
- not on bus- and/or supply/provisioning route
- (2) not on cycle route

IMPLEMENTATION

- ensure conspicuity with vertical elements, and provide adequate lighting
- the layout as shown above is preferable to its mirror image: see TM46
- at pedestrian crossing, lower kerb or construct a ramp

POSITIVE ASPECTS

- shorter crossing distance
- easier to cross street
- good speed reduction, even where there is no oncoming traffic - effect reinforced by turn

REMARKS:

Ref. Pages: SR1- 8, Ped 5, 13 (Appendix E)  
Literature: SARTSM; UTG1; CROW

DIMENSIONS

- $a = 3,25 - 3,5$  m
- $b \geq 1,5$  m
- $p =$  width of parking space
- $L = 5 - 10$  m
- lane deflection 15 to 30°
- if repeated on road section, leave enough space for overtaking trucks

ASSISTING MEASURES

- physical support: see TM7
- visual support measures: as for TM33

NEGATIVE ASPECTS

- could influence route choice
- possible acceleration when seeing oncoming traffic
- (2) crowding cyclists
- decrease in parking space, 3 - 4 on each side

DESCRIPTION

Slanted narrowing of roadway combined with cycle ways

MEASURE PAGE

TM53

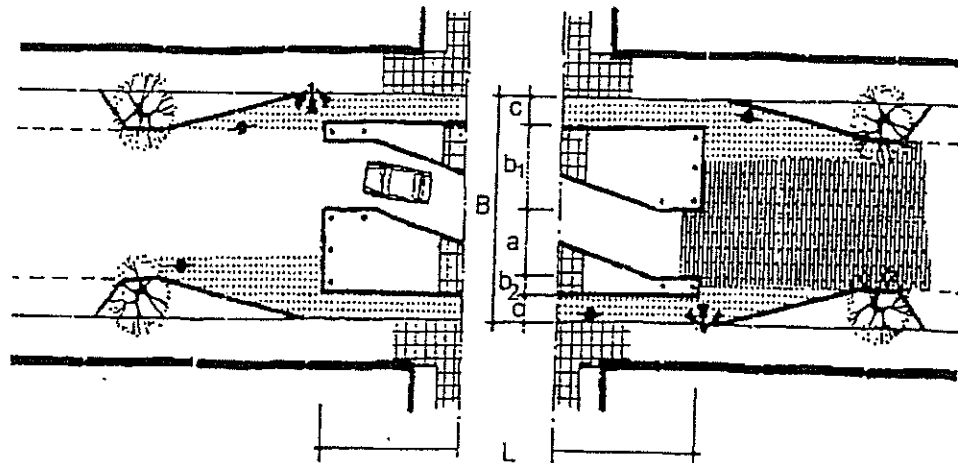
CONDITIONS FOR APPLICATION

- $B \geq 7,95$  m
- Peak hour volumes < 600 vph
- 85th percentile speed < 60 km/h
- not on major roads
- not on bus- and/or supply/provisioning route

DIMENSIONS

- $a = 3,25 - 3,5$  m
- $b_1 \geq 1,5$  m
- $b_2 \geq 0,5$  m
- $c = 1,35$  m
- $L = 5 - 10$  m
- lane deflection -  $15 - 30^\circ$
- taper cycle ways  $\leq 1:5$
- if repeated on road section, leave enough space for opposing HGVs to be able to pass

IMPLEMENTATION

- ensure conspicuity with vertical elements, and provide adequate lighting
- ensure adequate sight distances
- the layout as shown above is preferable to its mirror image: see TM46
- deflection islands at pedestrian crossing should not be raised
- at pedestrian crossing, lower kerb or construct a ramp

ASSISTING MEASURES

- physical assistance: see TM8
- visual support measures: as for TM33

POSITIVE ASPECTS

- shorter crossing distance and can be crossed in two stages
- easier to cross street
- good speed reduction, even where there is no oncoming traffic - effect reinforced by turn
- safe and comfortable way to separate cyclists from other traffic

NEGATIVE ASPECTS

- could influence route choice
- possible acceleration when seeing oncoming traffic
- cycle ways may be blocked by waiting vehicles
- cyclists have to filter into traffic after passing narrowing in roadway
- decrease in parking space: 5 - 6 on each side

REMARKS: Ref. Pages: SR1, 2, 3, 4, 6, 8, Ped 1, 9 (Appendix E)  
Literature: SARTSM; CROW

DESCRIPTION

Narrowing of roadway by multiple bayonet

MEASURE PAGE

TM54

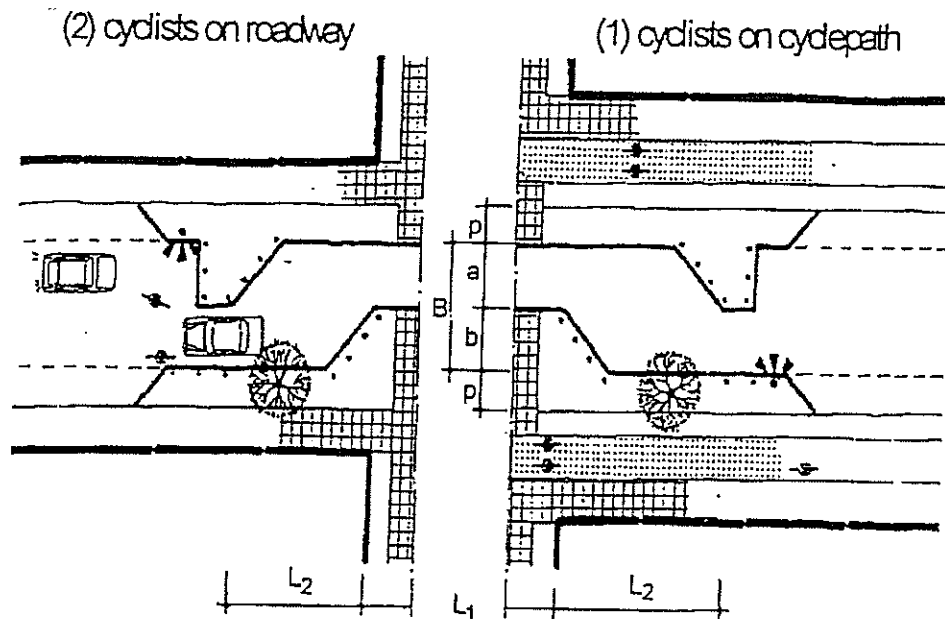
CONDITIONS FOR APPLICATION

- $B \geq 4,75$  m
- peak hour volumes < 400 vph
- not on major roads
- not on bus- and/or supply/provisioning route
- (2) not on cycle route

DIMENSIONS

- $a = 3,25 - 3,5$  m
- $b \geq 1,5$  m
- $p =$  width of parking space
- $L_1 = 5 - 10$  m
- $L_2 =$  depends on manoeuvrability of design vehicle

IMPLEMENTATION

- ensure conspicuity with vertical elements, and provide adequate lighting
- at pedestrian crossing, lower kerb or construct a ramp

ASSISTING MEASURES

- visual support measures: as for TM33

POSITIVE ASPECTS

- shorter crossing distance
- good speed reduction effect reinforced by turn
- easier to cross street

NEGATIVE ASPECTS

- could influence route choice
- (2) crowding of cyclists
- decrease in parking space, about 5 on each side
- very inconvenient for motor vehicles

REMARKS: Ref. Pages: SR3, 4, 7, 8, Ped 5, 13 (Appendix E)  
Literature: SARTSM; CROW, UTG1

DESCRIPTION

Narrowing of roadway by multiple bayonet combined with cycle ways

MEASURE PAGE

TM55

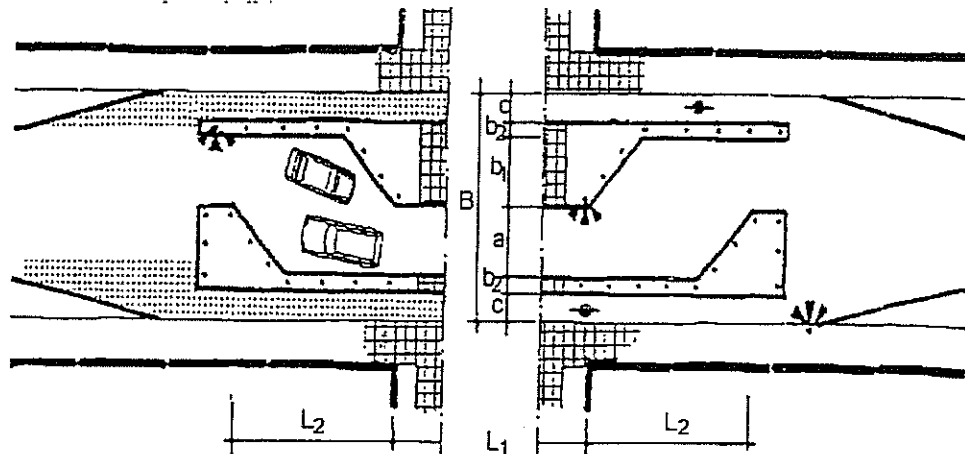
CONDITIONS FOR APPLICATION

- $B \geq 8,45$  m
- peak hour volumes < 400 vph
- 85th percentile speed < 60 km/h
- not on major roads
- not on bus- and/or supply/provisioning route

DIMENSIONS

- $a = 3,25 - 3,5$  m
- $b_1 \geq 1,5$  m
- $b_2 \geq 0,5$  m
- $c = 1,35$  m
- $L_1 = 5 - 10$  m
- $L_2 =$  depends on manoeuvrability of design vehicle
- taper cycle way  $\leq 1:5$

IMPLEMENTATION

- ensure conspicuity with vertical elements, and provide adequate lighting
- ensure visibility of on-coming traffic
- at pedestrian crossing, lower kerb or construct a ramp

ASSISTING MEASURES

- visual support measures: as for TM33

POSITIVE ASPECTS

- shorter crossing distance and can be crossed in two stages
- good speed reduction effect reinforced by turn
- easier to cross street

NEGATIVE ASPECTS

- could influence route choice
- cycle ways may be blocked by waiting cars
- cyclists have to filter into traffic after passing narrowing and bayonet
- little space on conductor on one side of road
- decrease in parking space: about 7 on each side
- very inconvenient for motor vehicles

REMARKS:

Ref. Pages: SR1, 2, 5, 6, Ped 1, 9 (Appendix E)  
Literature: SARTSM; CROW, UTG1



DESCRIPTION

Reduction/decreasing of lanes on 2 x 2 lane road

MEASURE PAGE

TM56

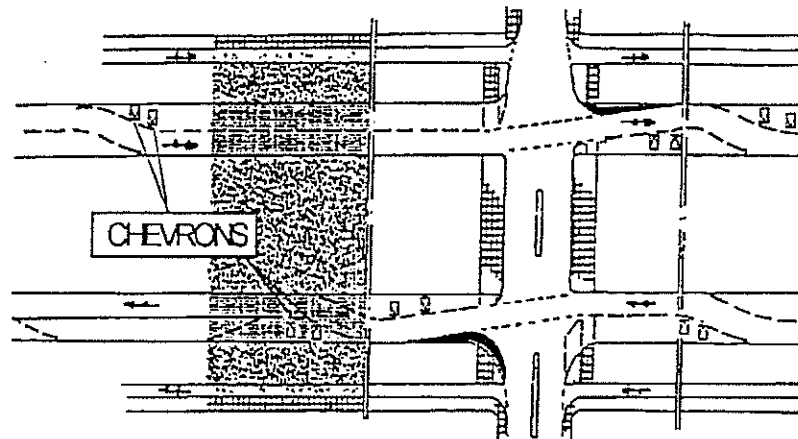
CONDITIONS FOR APPLICATION

- on 2 x 2 lane roads
- high frequency of pedestrians crossing
- cyclists on cycle way
- 85th percentile speed < 60 km/h

DIMENSIONS

- width of remaining lane 2,75 - 3,25 m
- distance between lane changes: about 100 m
- dimensions of lane changes depend on manoeuvrability of design vehicle

IMPLEMENTATION

- use strips stuck onto asphalt to mark narrowing of road
- danger plate signs to mark changes in lane clearly
- provide enough illumination

ASSISTING MEASURESPOSITIVE ASPECTS

- low to moderate speed reduction, depends largely on the distance between lane changes
- easier to cross road

NEGATIVE ASPECTS

- could divert traffic to less suitable streets
- could cause acceleration by channelising traffic
- no overtaking possibilities for emergency vehicles
- lanes could be blocked by a breakdown

REMARKS:

Ref. Pages: Ped 6, 8 (Appendix E)  
Literature: SARTSM; CROW, UTG1, Pedestrian Guidelines

DESCRIPTION

Horizontal curves before crossing

MEASURE PAGE

TM57

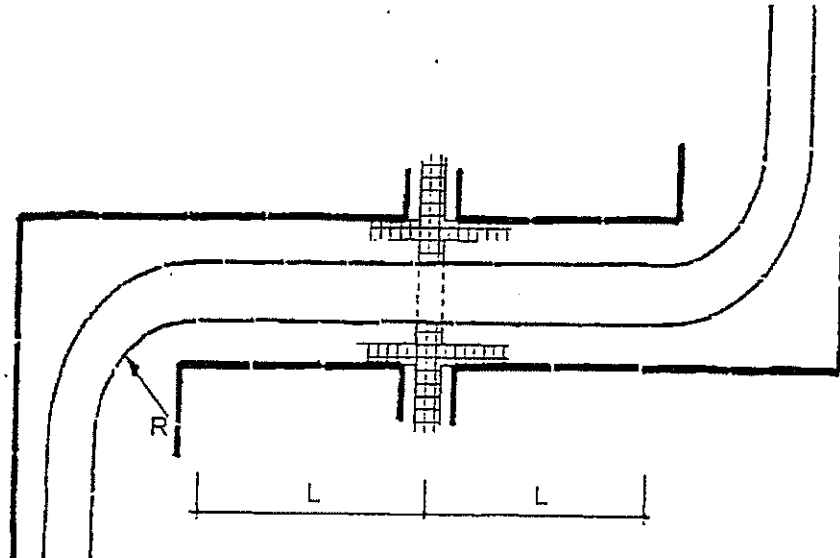
CONDITIONS FOR APPLICATION

- Peak hour volumes < 600 vph
- 85th percentile speed < 60 km/h

DIMENSIONS

- $R < 20$  m if speed is < 30 km/h
- $> 20$  m if speed is > 30 km/h
- $L = 30 - 50$  m
- if necessary, widen curve

IMPLEMENTATION

- ensure visibility of oncoming traffic, keep speed in mind (sight distance)
- if  $L > 50$  m, provide facilities for pedestrian crossing

ASSISTING MEASURESPOSITIVE ASPECTS

- good speed reduction
- user friendly

NEGATIVE ASPECTS

- motorists may cut corners

REMARKS: Ref. Pages: SR1, 3, 4, 5, 6, 7, 8, Ped 1,2,6, (Appendix E)  
Literature: UGT1; TRH17

DESCRIPTION

Overcoming level differences

MEASURE PAGE

TM58

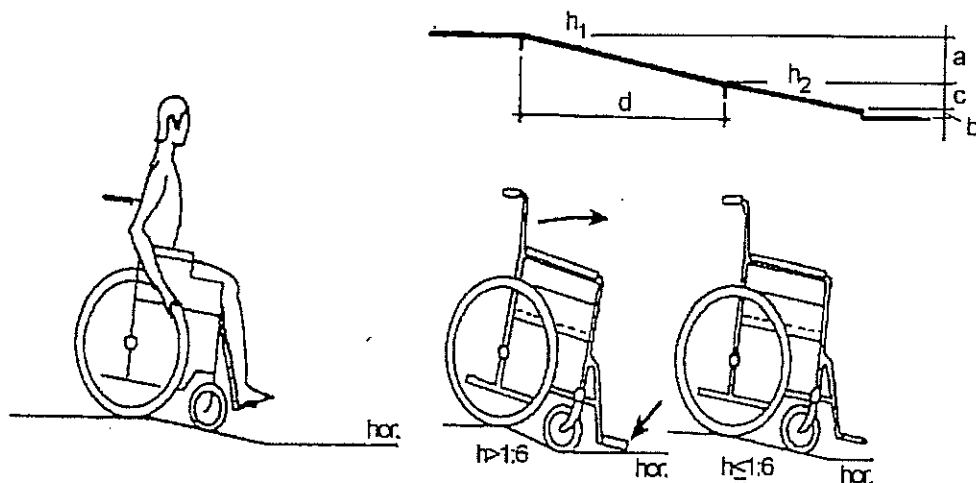
CONDITIONS FOR APPLICATION

- difference in levels > 10 cm

DIMENSIONS

- $h_1 = 1:6$
- $h_2 = 1:12 (1:9)$
- $a = 10 \text{ cm}$
- $b \leq 2 \text{ cm (gutter)}$
- $c = \text{remaining difference in height}$

IMPLEMENTATION

- site pedestrian crossing in such a way that the distance to be crossed is as short as possible
- concrete paving tiles and ramp (see TM60) or lower kerb (see TM59)
- eliminate different levels with gradient 1:20 by gradually reducing kerb height
- cover gutter
- virtually no transverse gradient

ASSISTING MEASURES

- guiding lines and warning signs: see SM11, 12
- provision of parking space: see Parking Standards
- provision of pedestrian crossing: see Pedestrian Guidelines

POSITIVE ASPECTS

- encourages safe and independent participation in traffic by the physically disabled

NEGATIVE ASPECTS

- when badly constructed (e.g. too great a transverse gradient on roadway) wheelchairs may get stuck or fall over

REMARKS:

Ref. Pages:  
Literature:

Han 2, 5, 8 (Appendix E)  
Parking standards; Pedestrian Guidelines; SARTSM

DESCRIPTION

Double sided choker to reduce to one lane

MEASURE PAGE

TM18

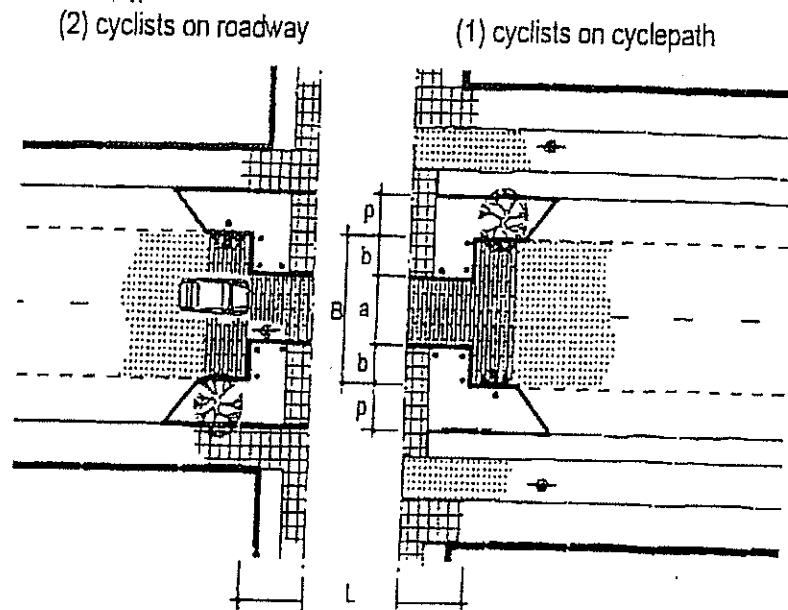
CONDITIONS FOR APPLICATION

- $B \geq 5,75 \text{ m (1)}$   
 $\geq 6,25 \text{ m (2)}$
- peak hour volumes < 400-600 vph
- 85 th percentile speed < 60 km/h
- two directional traffic should be proportionally split between directions
- not on major road
- (2) not on cycle route

DIMENSIONS

- $a = 2,75 - 3,25 \text{ m (1)}$   
 $= 3,25 - 3,50 \text{ m (2)}$
- $b \geq 1,5 \text{ m}$
- $p = \text{width of parking}$
- $L = 5 - 10 \text{ m}$
- with repeated use, ensure sufficient distance between chokers for two HGVs to pass one another

IMPLEMENTATION

- ensure conspicuity of vertical elements through provision of adequate lighting and marking
- ensure good visibility for opposing traffic
- provide ramps from pavements

ASSISTING MEASURES

- physical support: see TM16, 17, 26
- visual support measures - signs and marking, contrasting paving, greening, lighting

POSITIVE ASPECTS

- reduced crossing distance
- moderate to high speed reduction depending on volumes
- simple crossing situation

NEGATIVE ASPECTS

- could influence route choice
- possible speed increase from approaching traffic
- reduced parking space
- difficult for cyclists with (2)

REMARKS: Ref. Pages: MT6, SR4, 8, Ped 5, 13 (Appendix E)  
Literature: SARTSM, CROW

DESCRIPTION

Double sided choker narrowing to one lane with cycle lanes

MEASURE PAGE

TM19

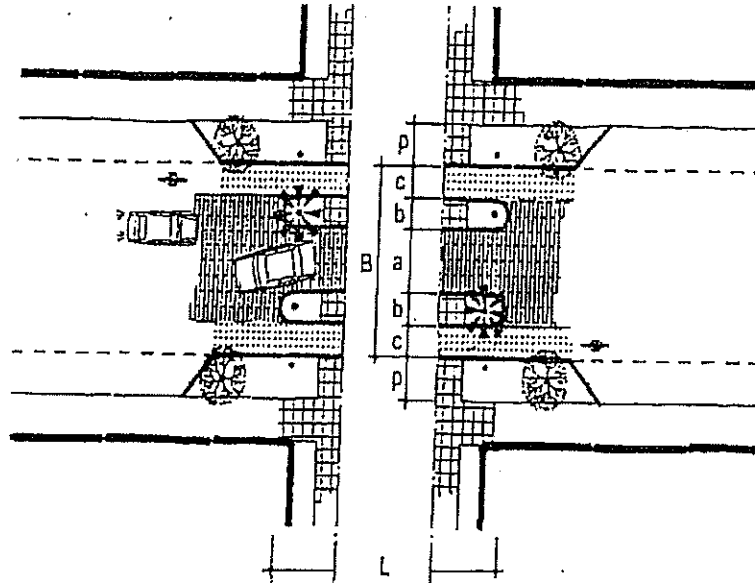
CONDITIONS FOR APPLICATION

- $B \geq 8,45$  m (crossing provision)  
 $\geq 7,45$  m (speed reduction)
- peak hour volumes < 400-600 vph
- even distribution of traffic in either direction
- 85th percentile speed < 60 km/h

DIMENSIONS

- $a = 2,75 - 3,25$  m
- $b \geq 1,5$  m (crossing provision)
- $\geq 1,0$  m (speed reduction)
- $c = 1,35$  m
- $p =$  width of parking bay
- $L = 5 - 10$  m

IMPLEMENTATION

- ensure conspicuity of vertical elements through provision of adequate lighting and marking
- ensure good sight distance for opposing approach traffic
- provide ramps from pavements
- contrasting material on cycle paths

ASSISTING MEASURES

- physical support: see TM17
- visual support measures - signing and marking, greening, contrasting paving, lighting

POSITIVE ASPECTS

- reduced crossing length with refuges
- moderate to high speed reduction depending on volumes
- excellent visibility (pedestrians)
- simple crossing situation

NEGATIVE ASPECTS

- can influence route choice
- limited space on island
- possible increase in approach speeds
- reduced parking space
- blocking of cycle path by cars

REMARKS: Ref. Pages: MT6, SR2, 4, 6, 8, Ped 1, 9 (Appendix E)  
Literature: SARTSM, CROW

DESCRIPTION

Extended two-sided choker

MEASURE PAGE

TM20

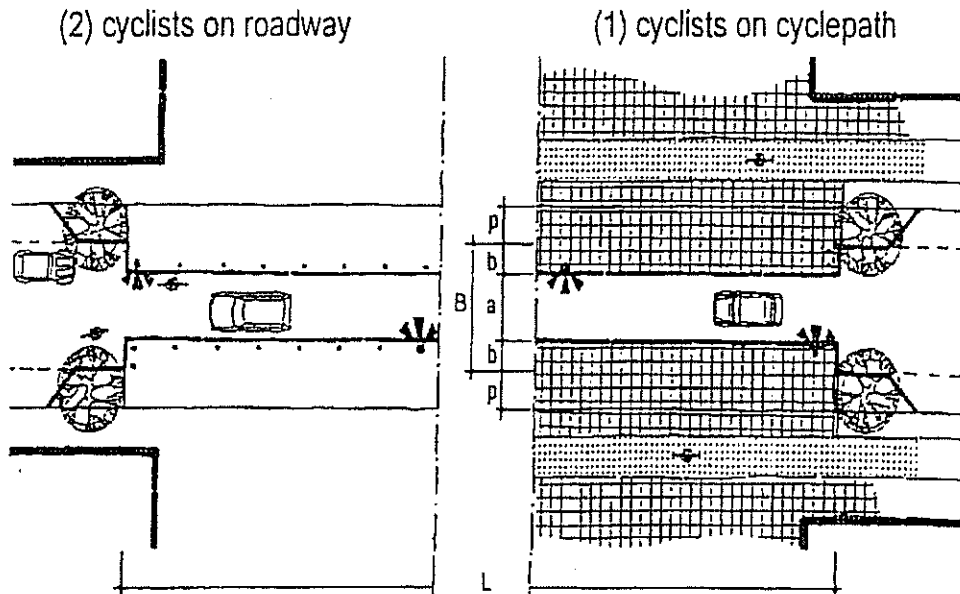
CONDITIONS FOR APPLICATION

- $B \geq 5,75 \text{ m (1)}$   
 $\geq 6,25 \text{ m (2)}$
- distributed crossing
- peak hour volumes < 400 vph
- 85 th percentile speed < 60 km/h
- not on major road
- even proportional split between traffic
- not to be used in isolation for speed reduction

DIMENSIONS

- $a = 2,75 - 3,25 \text{ m (1)}$   
 $= 3,25 - 3,5 \text{ m (2)}$
- $b \geq 1,5 \text{ m}$
- $p =$  width of parking bay
- $L < 50 \text{ m}$ , depending volumes

IMPLEMENTATION

- ensure conspicuity of vertical elements through provision of adequate lighting and marking
- ensure good sight distance for opposing traffic

ASSISTING MEASURESPOSITIVE ASPECTS

- shorter crossing distance for pedestrians
- moderate to high speed reduction depending on volumes
- simplified crossing situation

NEGATIVE ASPECTS

- could influence route choice
- after stopping, vehicles accelerate in the narrowed section
- reduced parking space
- difficult for cyclists (2), narrow if cars present

REMARKS:

Ref. Pages: Ped 13 (Appendix E)  
Literature: SARTSM, UTG1, CROW

DESCRIPTION

Extended two-sided choker with cycle paths

MEASURE PAGE

TM21

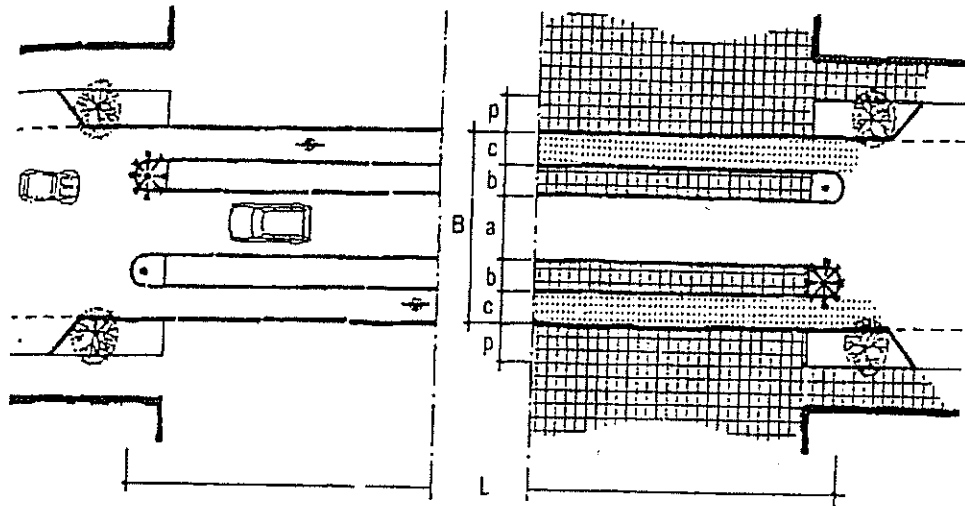
CONDITIONS FOR APPLICATION

- $B \geq 8,75$  m
- distributed crossing
- peak hour volumes < 400 vph
- 85th percentile speed < 60 km/h
- even directional split between traffic volumes
- not on major road
- not to be used in isolation for speed reduction

DIMENSIONS

- $a = 2,75 - 3,25$  m
- $b \geq 1,5$  m
- $c = 1,5 - 1,75$  m
- $p =$  width of parking bay
- $L < 50$  m, depending on volumes

IMPLEMENTATION

- ensure conspicuity of vertical elements through provision of adequate lighting and marking
- provide sufficient sight distance for opposing approach traffic

ASSISTING MEASURESPOSITIVE ASPECTS

- reduced crossing distance for pedestrians with refuges
- moderate to high speed reduction depending on volumes
- good visibility (pedestrians)
- safe for cyclists

NEGATIVE ASPECTS

- limited space on islands
- could influence route choice
- vehicles accelerate in the narrowed section
- reduced parking space

REMARKS: Ref. Pages: Ped 9 (Appendix E)  
Literature: UTG1, SARTSM

DESCRIPTION

Repeating two-sided chokers

MEASURE PAGE

TM22

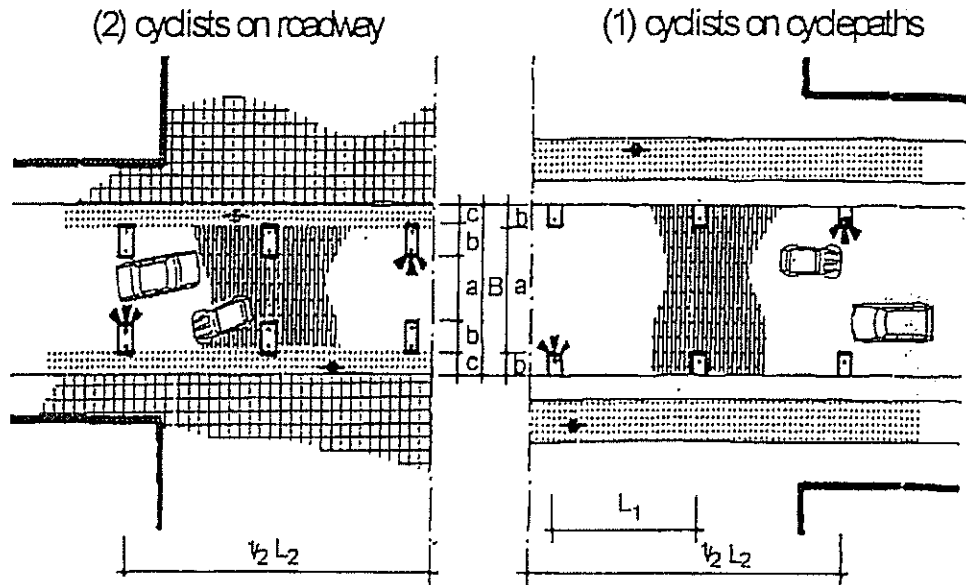
CONDITIONS FOR APPLICATION

- $B \geq 5,75$  m (1)  
 $\geq 8,45$  m (2)
- distributed crossing
- peak hour volumes < 600 vph if  $a < 3,25$  m and traffic is two-directional
- 85th percentile speed < 60 km/h if  $a < 3,25$  m and two-way traffic
- not on major road

DIMENSIONS

- $a = 2,75 - 5,0$  m (depending on volumes) with two-directional traffic
- $= 5,0 - 6,0$  m where high bus and HGV volumes exist
- $= 2,75 - 3,25$  with limited one-way traffic
- $b \geq 1,5$  m
- $c = 1,35$  m
- $L_1 = 10 - 20$  m
- $L_2 > 30$  m

IMPLEMENTATION

- chokers opposite one another
- ensure conspicuity of vertical elements through provision of adequate lighting and marking
- no parking if  $a \leq 3,25$  m and traffic is two-directional

ASSISTING MEASURESPOSITIVE ASPECTS

- moderate speed reduction if  $a = 5,0$  m
- high speed reduction if  $a = 3,0$  m, depending on volumes
- shorter crossing distance for pedestrians
- safe for cyclists

NEGATIVE ASPECTS

- limited physical protection for pedestrians
- parking between narrowed sections could influence route choice
- not very attractive

REMARKS: Ref. Pages: SR1-8, Ped 9 - 16 (Appendix E)  
Literature: UTG1; SARTSM; CROW



DESCRIPTION

Continuous two-sided choker through the construction of cycle paths

MEASURE PAGE

TM23

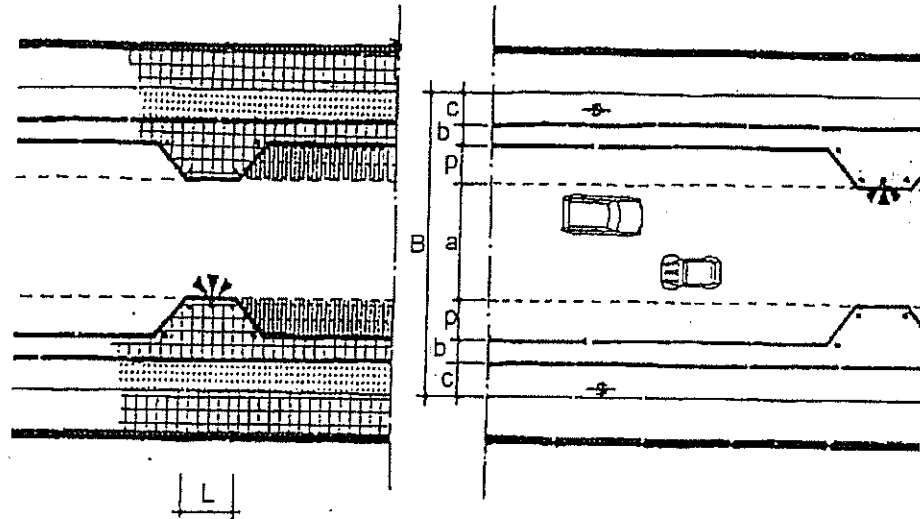
CONDITIONS FOR APPLICATION

- $B \geq 13,6$  m (two way traffic)
- $\geq 11,85$  m (limited one-way traffic)
- distributed crossing

DIMENSIONS

- $a = 4,5 - 5,0$  m (two way traffic)
- $= 5,0 - 6,0$  m where high bus and/or HGV volumes exist
- $= 2,75 - 3,25$  (one way traffic)
- $b \geq 1,0$  m
- $p = 1,8 - 2,0$  m
- $c \geq 1,75$  m
- $L = 2 - 4$  m
- distance between chokers 3 - 4 parking bays (i.e. 16,5 - 24 m)

IMPLEMENTATION

- vertical elements to be placed on the chokers

ASSISTING MEASURES

- physical support see TM16, 18, 26

POSITIVE ASPECTS

- shorter crossing distance for pedestrians and refuges provided for staged crossing
- moderate reduction in speed
- safe for cyclists

NEGATIVE ASPECTS

- parking space reduced by about a quarter

REMARKS: Ref. Pages: SR5, 6, Ped 10 - 12 (Appendix E)  
Literature: CROW, UTG1, SARTSM

DESCRIPTION

Extended two-sided choker with pedestrian side strips

MEASURE PAGE

TM24

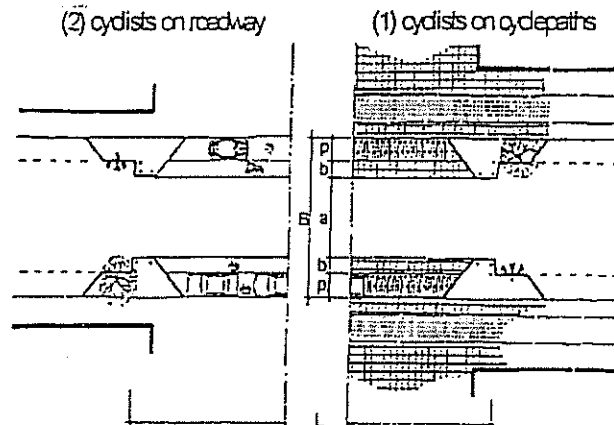
CONDITIONS FOR APPLICATION

- $B \geq 8,35$  (1)  
 $\geq 8,85$  (2)
- distributed crossing
- peak hour volumes  $< 600$  vph if  $a \leq 3,25$  m and traffic is two-way
- 85th percentile speed  $< 60$  km/h if  $a \leq 3,25$  m and traffic is two-way
- not to be used in isolation for speed reduction

DIMENSIONS

- with two-way traffic
  - $a = 4,5 - 5,0$  m (1)
  - $= 5,0 - 6,0$  m (2) or with high bus and/or HGV volumes
  - $= 2,75 - 3,25$  (1) and low volumes
- with one-way traffic
  - $a = 2,75 - 3,25$  (1)
  - $= 3,25 - 3,5$  (2)
- $b \geq 1,5$  m
- $p = 1,8 - 2,0$  m
- $L < 50$  m with two-way traffic and narrowing to one lane
- distance between chokers  $< 25$  m

IMPLEMENTATION

- ensure conspicuity of vertical elements through provision of adequate lighting and marking
- contrasting pavement material of parking areas and pedestrian strips
- ensure adequate sight distance for opposing approach traffic

ASSISTING MEASURESPOSITIVE ASPECTS

- holding area between parking bays and roadway
- reduced crossing length for pedestrians
- excellent pedestrian visibility
- moderate to high reduction in speed

NEGATIVE ASPECTS

- incorrect parking
- reduced parking space
- with high parking demand, double parking
- space restriction for cyclists (2)

REMARKS:

Ref. Pages:  
Literature:

Ped 11, 14, 15, 16 (Appendix E)  
CROW; UTG1; SARTSM; Pedestrian Guidelines

DESCRIPTION

One-sided choker

MEASURE PAGE

TM26

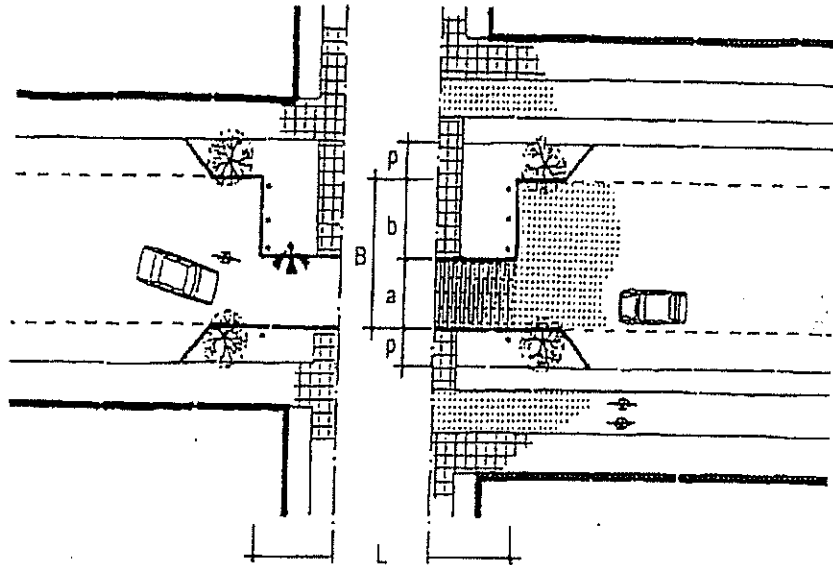
CONDITIONS FOR APPLICATION

- $B \geq 4,25 \text{ m (1)}$   
 $\geq 4,75 \text{ m (2)}$
- concentrated crossing
- peak hour volumes < 600 vph
- 85th percentile speed < 60 km/h
- not on major roads
- even directional split with two-way traffic
- not on cycle route (2)

DIMENSIONS

- $a = 2,75 - 3,25 \text{ m (1)}$   
 $= 3,25 - 3,5 \text{ m (2)}$
- $b \geq 1,5 \text{ m}$
- $p = \text{width of parking bay}$
- $L = 5 - 10 \text{ m}$
- with repeated application ensure that the distance between chokers is sufficient for two HGVs to pass one another

IMPLEMENTATION

- ensure conspicuity with vertical elements, marking and adequate lighting
- ensure adequate sight distance for opposing traffic
- adequate sight distance should also be provided in the curve

ASSISTING MEASURES

- physical support measures: see TM16, 17, 26

POSITIVE ASPECTS

- shortened crossing distance for pedestrians
- moderate to high reduction in speed, depending on volumes
- simplified crossing situation for pedestrians
- priority for vehicles at choker self-apparent

NEGATIVE ASPECTS

- could influence route choice
- narrow for cyclists (2)
- reduced parking

REMARKS: Ref. Pages: SR4, 8, Ped 1,5 (Appendix E)  
Literature: CROW, UTG1, SARTSM

DESCRIPTION

One-sided narrowing with 2 cycle paths

MEASURE PAGE

TM27

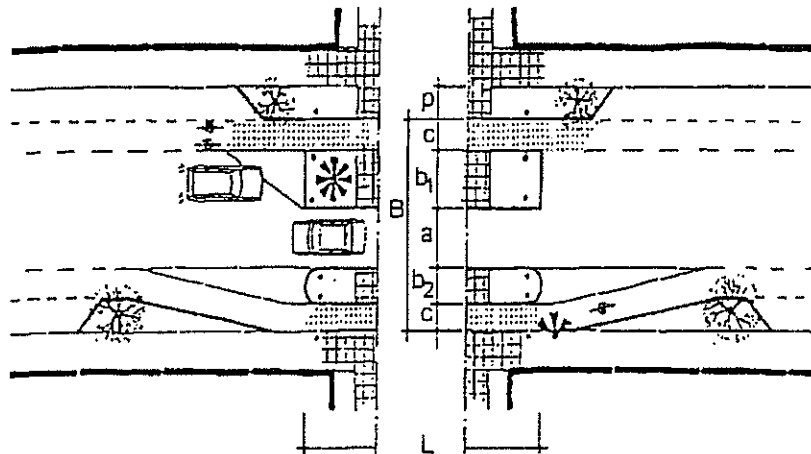
CONDITIONS FOR APPLICATION

- $B \geq 9,2$  m
- peak hour volumes < 600 vph
- 85th percentile speed < 60 km/h
- not on major roads
- even directional split with two-way traffic

DIMENSIONS

- $a = 2,75 - 3,25$  m
- $b_1 \geq 2,25$  m
- $b_2 \geq 1,5$  m
- $c = 1,35$  m
- $p =$  width of parking bay
- $L = 5 - 10$  m
- with repeated use ensure adequate distance between them to allow two HGVs to pass one another

IMPLEMENTATION

- ensure conspicuity with vertical elements, marking and adequate lighting
- ensure adequate sight distance for opposing traffic
- adequate sight distance should also be provided in the curve
- provide ramps from pavements and islands

ASSISTING MEASURES

- physical support measures: see TM17

POSITIVE ASPECTS

- shortened crossing distance and refuges for staged crossing
- good visibility (pedestrians)
- moderate to high reduction in speed, depending on volumes
- safe for cyclists
- priority for vehicles self evident

NEGATIVE ASPECTS

- could influence route choice
- reduced parking
- limited space on islands for furniture

REMARKS:

Ref. Pages: SR6, Ped 1, 9 (Appendix E)  
Literature: SARTSM; CROW, UTG1

DESCRIPTION

One-sided narrowing to one lane with 1 cycle path

MEASURE PAGE

TM28

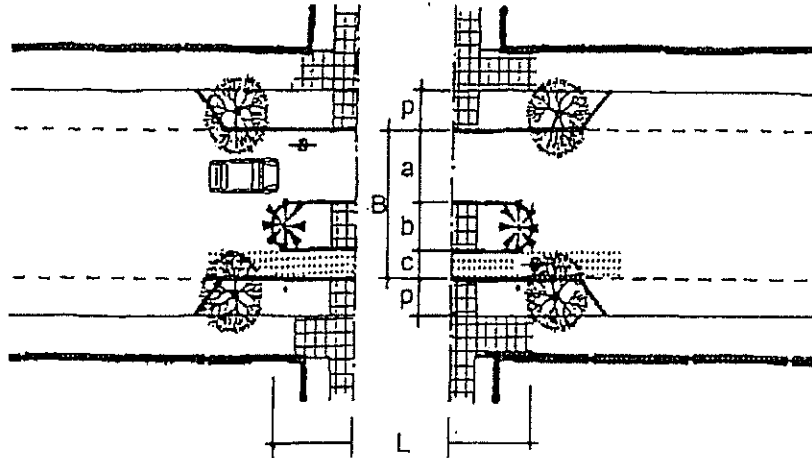
CONDITIONS FOR APPLICATION

- $B \geq 6,1$  m
- concentrated crossings
- peak hour volumes < 600 vph
- 85th percentile speed < 60 km/h
- not on major roads
- even directional split with two-way traffic

DIMENSIONS

- $a = 3,25 - 3,5$  m
- $b \geq 1,5$  m
- $c = 1,35$  m
- $p =$  width of parking bay
- $L = 5 - 10$  m
- with repeated use ensure sufficient distance between them for two HGVs to pass one another

IMPLEMENTATION

- ensure conspicuity with vertical elements, marking and lighting
- ensure adequate sight distance
- provide ramps from pavements and islands

ASSISTING MEASURES

- physical support measures: see SM17
- visual support measures - signing and marking, greening contrasting paving

POSITIVE ASPECTS

- reduced crossing length with pedestrian refuges
- moderate to high reduction in speed, depending on volumes
- good visibility (pedestrians)
- safe for cyclists

NEGATIVE ASPECTS

- limited space on islands for furniture
- could influence route choice
- cycle paths can be blocked by cars
- reduced parking spaces

REMARKS:

Ref. Pages: Ped 1, 2, 3, 4; SR2, 6  
Literature: CROW, UTG1, SARTSM.

DESCRIPTION

Long one-sided narrowing

MEASURE PAGE

TM29

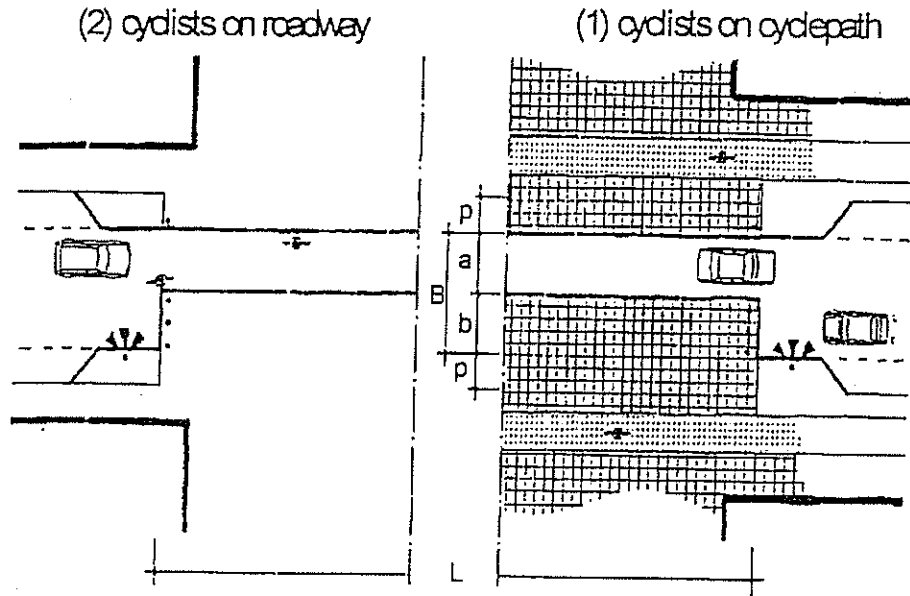
CONDITIONS FOR APPLICATION

- $B \geq 4,25$  m
- distributed crossings
- peak hour volumes < 400 vph
- 85th percentile speed < 60 km/h
- not on major roads
- even directional split with two-way traffic
- not on cycle route (2)
- not on bends
- only as a crossing provision

DIMENSIONS

- $a = 2,75 - 3,25$  m (1)
- $a = 3,25 - 3,5$  m (2)
- $b \geq 1,5$  m
- $p =$  width of parking bay
- $L < 50$  m, depending on volumes

IMPLEMENTATION

- ensure conspicuity with vertical elements, marking and lighting
- ensure sufficient sight distance

ASSISTING MEASURESPOSITIVE ASPECTS

- reduced crossing length
- moderate to high reduction in speed, depending on volumes
- improved (simplified) crossing situation

NEGATIVE ASPECTS

- can influence route choice
- vehicles accelerate from standstill in the narrowed section
- narrow for cyclists (2)

REMARKS:

Ref. Pages: Ped 13 (Appendix E)  
Literature: CROW

DESCRIPTION

Sidewalk ramp

MEASURE PAGE

TM59

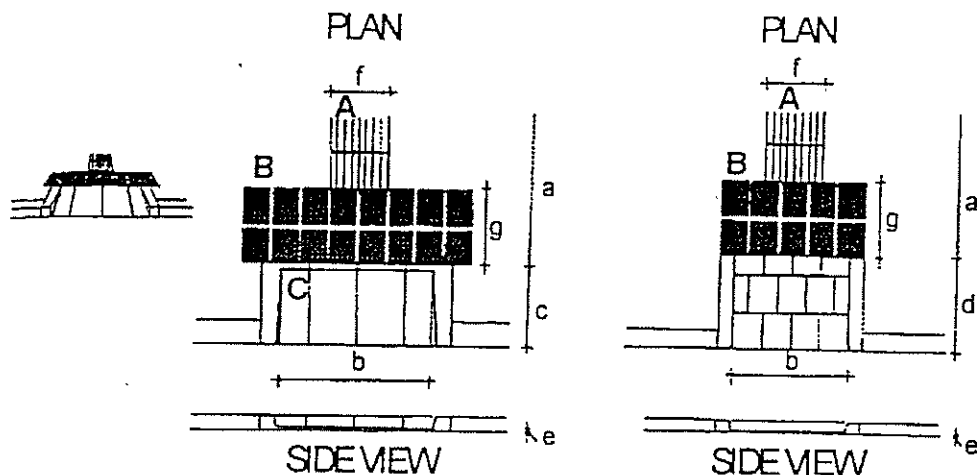
CONDITIONS FOR APPLICATION

- width of sidewalk  $\geq 2,30$  (2,15) m
- transverse gradient of roadway  $\leq 1:50$

DIMENSIONS

- $a \geq 1,5$  m
- $b = 1,5$  (1,2) m
- $c = 0,8$  m, where ramp gradient 1:8  
= 0,65 m, where ramp gradient 1:6
- $d = 0,75$  m
- $e \leq 2$  cm (gutter)
- $f = 60$  cm
- $g = 60$  cm

IMPLEMENTATION

- site pedestrian crossing in such a way that the distance to be crossed is as short as possible
- guiding lines and warning signs optional (see assisting measure)
- it is not necessary to construct ramp over full width of pedestrian crossing. If warning tiles are used, use over whole width

ASSISTING MEASURES

- guiding lines and warning signs: see SM11, 12
- provision of pedestrian crossing: see Pedestrian Guidelines

POSITIVE ASPECTS

- tactile information clear and comprehensible to the visually impaired
- very little inconvenience for other users
- encourages safe and independent participation in traffic situation by the physically disabled
- little or no drainage problems

NEGATIVE ASPECTS

- difficult to implement
- no continuity in walkway
- concrete ramp not easy to move over
- steep ramp is inconvenient for the less mobile and aged pedestrians

REMARKS:

Ref. Pages: Han 2, 5, 8 (Appendix E)  
 Literature: SARTSM; Pedestrian Guidelines, UTG1

DESCRIPTION

Lowering part of pavement

MEASURE PAGE

TM60

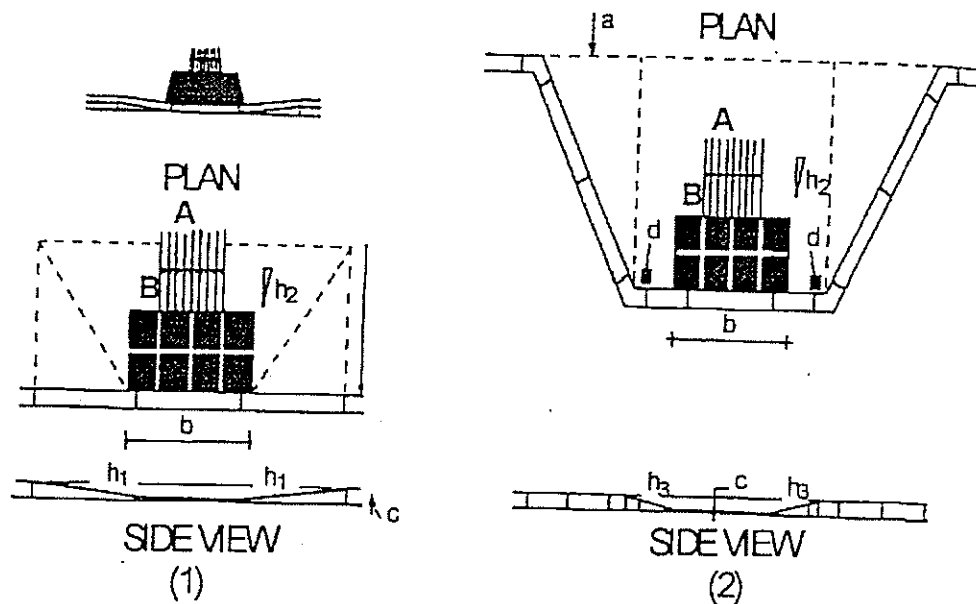
CONDITIONS FOR APPLICATION

- width of sidewalk  $\geq 1,5$  m excluding kerb
- (2) where there is a parking area

DIMENSIONS

- $a \geq 1,5$  m (1)
- $a \geq 1,2$  (0,90) m (2)
- $b = 1,5$  (1,2) m
- $c \leq 2$  cm (gutter)
- guiding post in contrasting colour (visual assistance) to a height of 0,75 (0,60) m
- $h_1 = 1:20$  (1:12)
- $h_2 = 1:12$  (1:9)
- $h_3 = 1:10$

IMPLEMENTATION

- site pedestrian crossing in such a way that the distance to be crossed is as short as possible
- guiding line and warning signs optional

ASSISTING MEASURES

- guiding lines and warning signs: see SARTSM
- provision of pedestrian crossing: see Pedestrian Guidelines

POSITIVE ASPECTS

- tactile information clear and comprehensible to the visually impaired
- convenient for the aged and less mobile
- easy and inexpensive to construct
- (2) shorter distance to cross and improved visibility for pedestrians crossing
- encourages safe and independent participation in traffic situation by the physically disabled

NEGATIVE ASPECTS

- (1) if the pavement is narrow, this may cause considerable inconvenient to wheelchair users
- physically disabled may be less conscious of going onto roadway

REMARKS:

Ref. Pages: Han 2, 5, 8 (Appendix E)  
Literature: SARTSM; Pedestrian Guidelines, UTG1<sup>1</sup>



DESCRIPTION

Raising of intersection

MEASURE PAGE

TM61

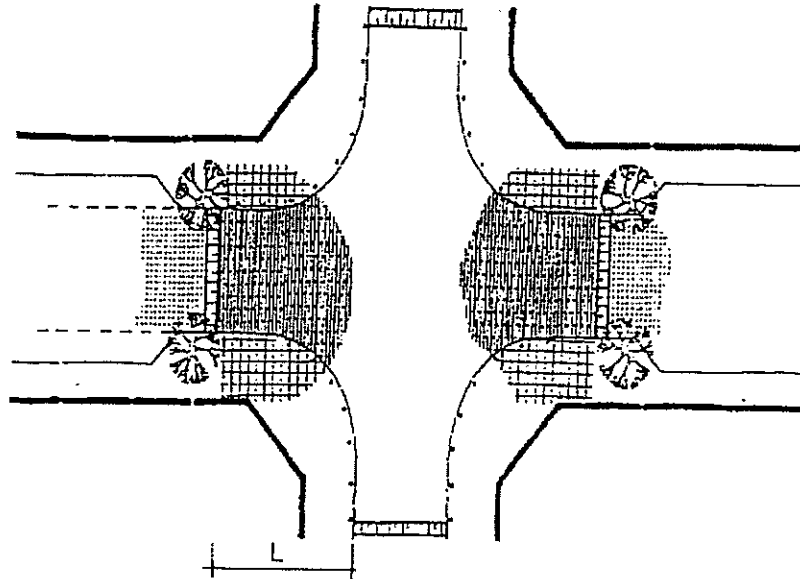
CONDITIONS FOR APPLICATION

- peak hour volumes < 600 vph
- 85th percentile speed < 60 km/h
- not on major roads
- not on bus- and/or supply/provisioning route
- not on cycle route

DIMENSIONS

- difference in levels 10 - 20 cm
- L = about 10 m
- gradient 1:10 or more

IMPLEMENTATION

- vehicles should be able to maintain an acceptable speed (liability of authorities)
- ensure conspicuity with vertical elements and provide adequate lighting
- vertical elements on curve radii
- trapezium shaped in length
- ramps may be necessary

ASSISTING MEASURES

- physical supports: see TM66, 73
- visual support: see SM9

POSITIVE ASPECTS

- fair speed reduction
- suitable for the physically disabled
- reduces speed of motor cyclists

NEGATIVE ASPECTS

- noise pollution and vibration
- could influence route choice
- inconvenient for cyclists

REMARKS:

Ref. Pages: Han 2, 5, 8, 9, 10 (Appendix E)  
Literature: Pedestrian Guidelines, SARTSM, UTG1

Note: This has been applied to a limited extent in South Africa and results have generally been favourable

DESCRIPTION

Raising of intersection with cycle path

MEASURE PAGE

TM62

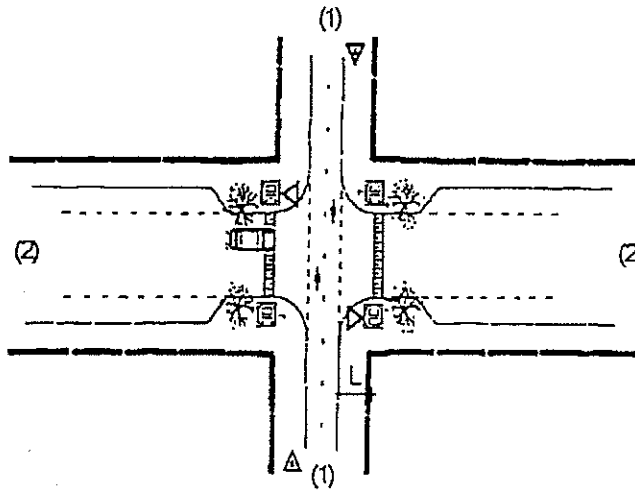
CONDITIONS FOR APPLICATION

- peak hour volumes < 600 vph (2)
- 85th percentile speed < 60 km/h on (2)
- not on bus- and/or supply/provisioning route on (2)
- [no cycle route on (2)]

DIMENSIONS

- difference in levels 10 - 12 cm
- L = 4 - 5 m
- gradient 1:10 or more (maximum 1:6)

IMPLEMENTATION

- cycle path should have priority or have priority at intersection. To implement this the 30 km/h zone on (2) is interrupted
- vehicles should be able to pass obstructions at an acceptable speed (liability of authority)
- trapezium shape in length
- (1) gradual merging of different levels

ASSISTING MEASURESPOSITIVE ASPECTS

- high quality cycle route on (1)
- good speed reduction on (2)
- reduction of speed of motor cyclists on (2)

NEGATIVE ASPECTS

- noise pollution and vibration
- could influence route choice
- inconvenient for cyclists on (2)
- short interruption

REMARKS:

Ref. Pages: SR1, 2, 3, 4, 6, 8  
Literature: SARTSM; CROW, UTG1

DESCRIPTION

Realignment using left and right bayonets at intersection

MEASURE PAGE

TM63

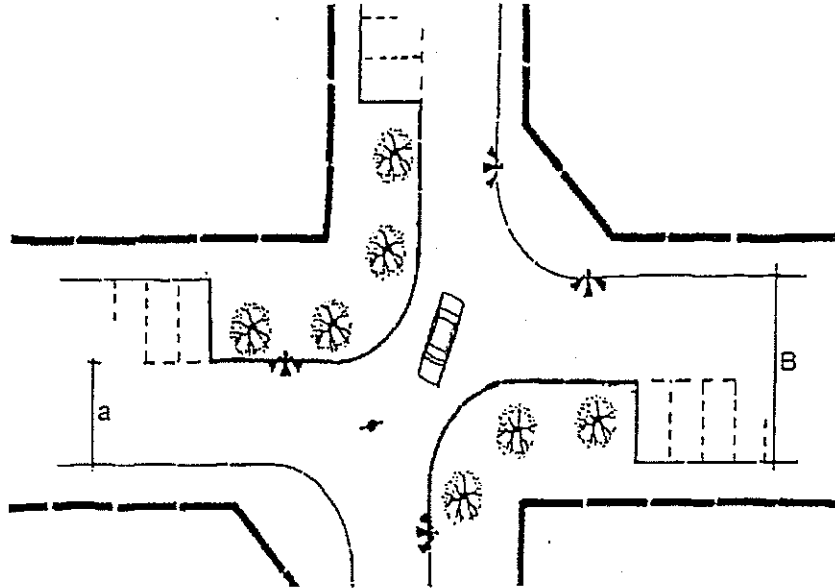
CONDITIONS FOR APPLICATION

- $B \geq 9,5$  m, where parking angle is  $90^\circ$
- $\geq 8,9$  m, where parking angle is  $60^\circ$
- $\geq 8,1$  m, where parking angle is  $45^\circ$
- peak hour volumes  $< 400$  vph on each road
- not on major roads
- not on cycle route with variable parking space

DIMENSIONS

- $a = 4,5 - 5$  m, two-way traffic
- $= 5 - 6$  m, bus and/or truck traffic
- width of roadway depends on parking angle
- turning curves depend on manoeuvrability of design vehicle

IMPLEMENTATION

- ensure conspicuity with vertical elements and provide adequate lighting
- ensure adequate sight distances
- parking angle of  $30^\circ$  should not be used.

ASSISTING MEASURES

- physical support: see TM61

POSITIVE ASPECTS

- moderate to good reduction in speed for through traffic
- visual relief on the perpendicular
- shorter distance to cross the diagonal

NEGATIVE ASPECTS

- situation is easy to misjudge

REMARKS: Ref. Pages: SR5- 8  
Literature: SARTSM; UTG1

DESCRIPTION

Realignment by two right-turning bayonets at intersection

MEASURE PAGE

TM64

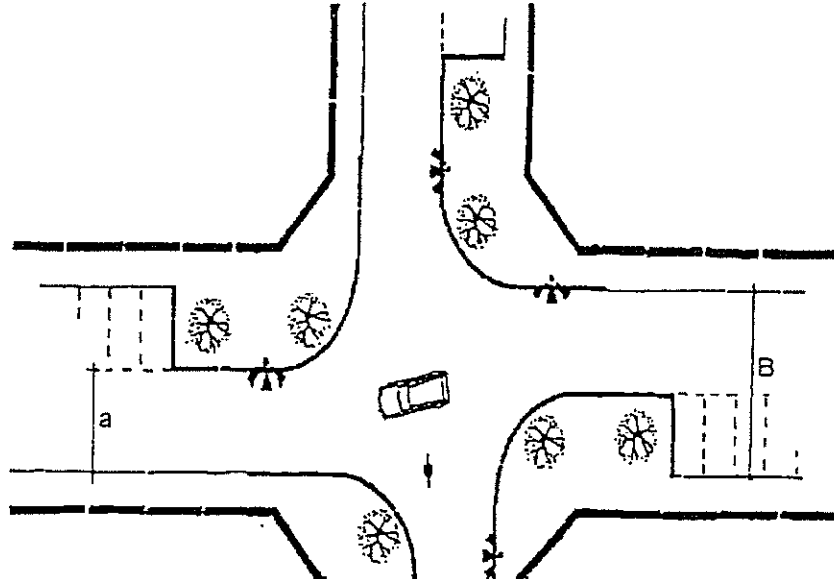
CONDITIONS FOR APPLICATION

- $B \geq 9,5$  m, where parking angle is  $90^\circ$   
 $\geq 8,9$  m, where parking angle is  $60^\circ$   
 $\geq 8,1$  m, where parking angle is  $45^\circ$
- peak-hour volumes  $< 400$  vph on each road
- not on major roads
- not on cycle route with variable parking space

DIMENSIONS

- $a = 4,5 - 5$  m, with two-way traffic  
 $= 5 - 6$  m, with bus and/or truck traffic
- width of roadway depends on parking angle
- turning curves depend on manoeuvrability of design vehicle

IMPLEMENTATION

- ensure conspicuity with vertical elements and provide adequate lighting
- ensure adequate sight distances
- parking angle of  $30^\circ$  should not be used.

ASSISTING MEASURES

- physical support: see TM61

POSITIVE ASPECTS

- moderate to good reduction in speed for non turning traffic
- visual relief on the perpendicular

NEGATIVE ASPECTS

- situation is easy to misjudge

REMARKS: Ref. Pages: SR5- 8  
 Literature: SARTSM; UTG1; CROW

DESCRIPTION

Realignment of T-junction

MEASURE PAGE

TM65

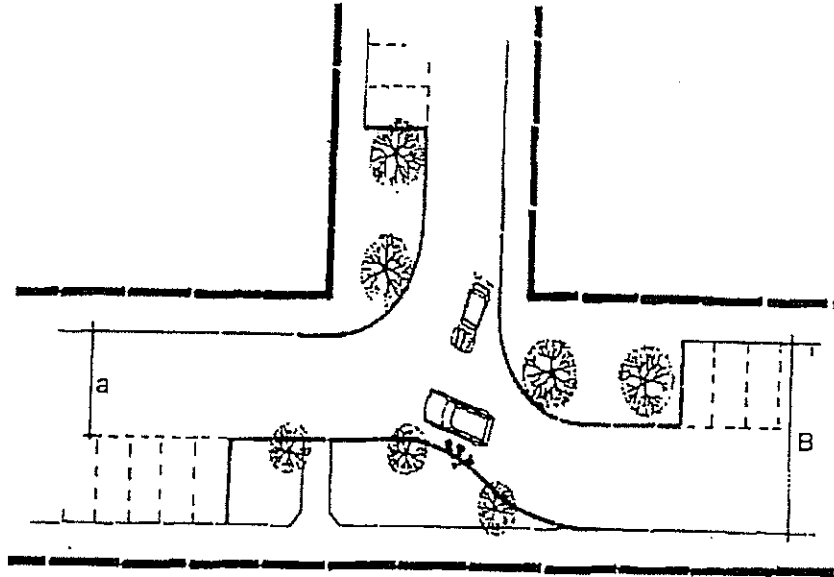
CONDITIONS FOR APPLICATION

- $B \geq 9,5$  m, where parking angle is  $90^\circ$
- $\geq 8,9$  m, where parking angle is  $60^\circ$
- $\geq 8,1$  m, where parking angle is  $45^\circ$
- peak hour volumes  $< 400$  vph
- not on major road
- not on cycle route with high parking turnover
- two-way traffic

DIMENSIONS

- $a = 4,5$  to  $5$  m, with two-way traffic
- $= 5$  to  $6$  m, with bus and/or truck traffic
- width of roadway depends on parking angle
- turning curves depend on manoeuvrability of design vehicle

IMPLEMENTATION

- ensure conspicuity with vertical elements and provide adequate lighting
- ensure adequate sight distances
- parking angle of  $30^\circ$  should preferably not be used on account of lack of space

ASSISTING MEASURES/  
POSSIBLE COMBINATIONS

- physical support: see TM61

POSITIVE ASPECTS

- moderate to good reduction in speed for non-turning vehicles
- visual relief without impeding sight distance

NEGATIVE ASPECTS

- situation is easy to misjudge

REMARKS:

Ref. Pages: SR5-9  
Literature: SARTSM, CROW, UTG1

DESCRIPTION

Reduction of intersection area by eliminating parking areas/parking lanes

MEASURE PAGE

TM66

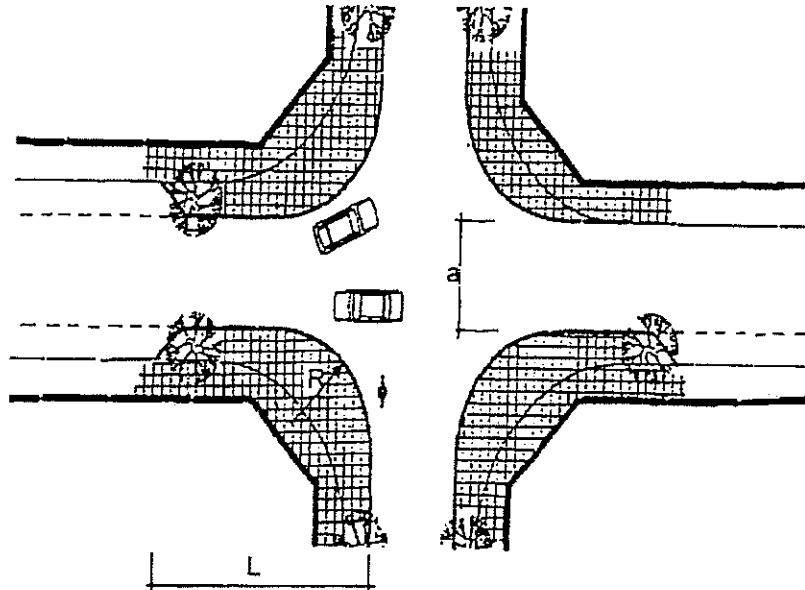
CONDITIONS FOR APPLICATION

- high volume of pedestrians crossing
- peak hour intersection volumes < 800 vph
- roads with high parking ratio
- where medians are impossible or undesirable

DIMENSIONS

- $a = 4,5$  to  $5$  m, with two-way traffic
- $= 5$  to  $5,5$  m, with bus and/or truck traffic
- $= 3,25$  to  $3,5$  m, with one-way traffic
- $R$  depends on manoeuvrability of design vehicle
- $L \geq 10$  (5) m

IMPLEMENTATION

- lower kerb or construct a ramp to accommodate pedestrian crossing

ASSISTING MEASURES/  
POSSIBLE COMBINATIONS

- physical support: see TM11, 72, 73

POSITIVE ASPECTS

- shorter distance to cross
- better visibility
- attention-getter for junction
- improvement of overall view/visibility
- moderate speed reduction for turning vehicles

NEGATIVE ASPECTS

- no speed reduction for non-turning vehicles

REMARKS:

Ref. Pages: SR1 - 4, Ped 1, 2, 3, 5, 6, 7 Appendix E)  
Literature: SARTSM, CROW, UTG1, Pedestrian Guidelines

DESCRIPTION

Reduction of intersection area by narrowing of roadways

MEASURE PAGE

TM67

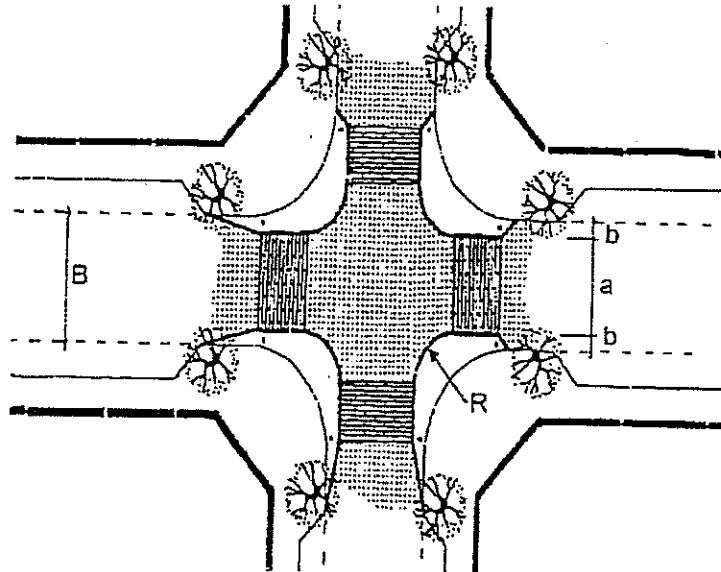
CONDITIONS FOR APPLICATION

- $B \geq 6,5$  m with two-way traffic  
 $\geq 5,25$  m, with partial one-way traffic
- not on main roads
- not on bus and/or supply routes
- 85th percentile speed < 60 km/h
- high volumes of pedestrians crossing
- peak hour intersection volumes < 800 vph

DIMENSIONS

- $a = 4,5$  to 5 m, with two-way traffic  
 $= 3,25$  to 3,5 m, with partial one-way traffic
- $b \geq 1$  m
- $R$  depends on manoeuvrability of design vehicle

IMPLEMENTATION

- ensure conspicuity with vertical elements and provide adequate lighting
- lower kerb or construct a ramp to accommodate pedestrian crossing

ASSISTING MEASURES/  
POSSIBLE COMBINATIONS

- physical support: see TM11
- signing and marking, contrasting paving, lighting and greening

POSITIVE ASPECTS

- shorter distance to cross
- improvement of visibility for pedestrians
- moderate speed reduction

NEGATIVE ASPECTS

- crowding of cyclists

REMARKS:

Ref. Pages: SR1 - 4, 6, 8, Ped, 3, 5, 7 (Appendix E)  
 Literature: SARTSM, CROW, UTG1, Pedestrian Guidelines

DESCRIPTION

Reduction of intersection area at T-junction

MEASURE PAGE

TM68

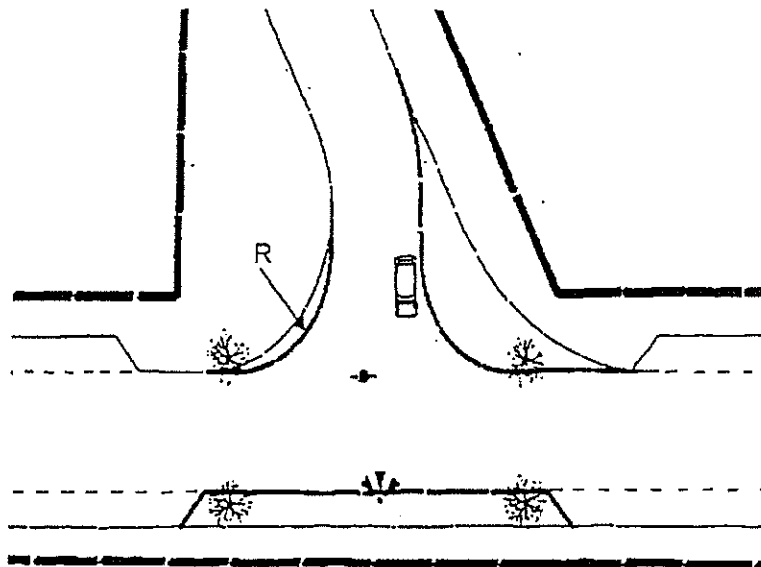
CONDITIONS FOR APPLICATION

- Peak hour intersection volumes < 800 vph

IMPLEMENTATION

- lower kerb or construct a ramp to accommodate pedestrian crossing

POSITIVE ASPECTS

- shorter distance to cross
- improvement of visibility
- moderate speed reduction

DIMENSIONS

- R depends on manoeuvrability of design vehicle

ASSISTING MEASURES/  
POSSIBLE COMBINATIONS

- physical support: see TM61
- visual support: see signing and marking, contrasting paving, greening, lighting

NEGATIVE ASPECTS

- no speed reduction for non-turning traffic

REMARKS:

Ref. Pages:

SR1 - 4, 8

Literature:

SARTSM, CROW, UTG1, Pedestrian Guidelines



DESCRIPTION

Protrusion on T-junction

MEASURE PAGE

TM69

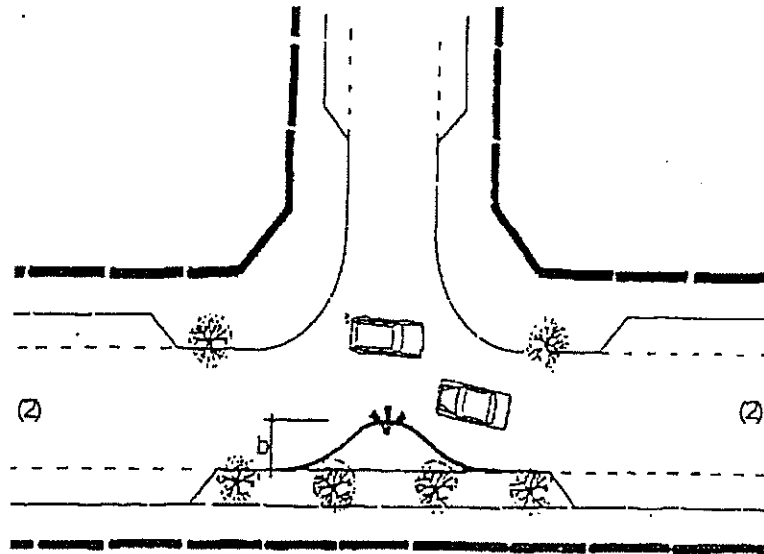
CONDITIONS FOR APPLICATION

- Peak hour volumes on major road (2) < 600 vph
- 85th percentile speed (2) < 60 km/h
- not on major road
- not on cycle route

DIMENSIONS

- $b \geq 1,5$  m, depending on width of roadway and manoeuvrability of design vehicle

IMPLEMENTATION

- ensure conspicuity with vertical elements and provide adequate lighting

ASSISTING MEASURES/  
POSSIBLE COMBINATIONS

- physical support: see SM3
- visual support: see signing and marking, contrasting paving, greening, lighting
- cycle lane instead of parking strip: see TM27

POSITIVE ASPECTS

- moderate to good speed reduction
- attention-getter for T-junction

NEGATIVE ASPECTS

- crowding of cyclists
- situation is easy to misjudge

REMARKS:

Ref. Pages: SR1 - 4, 6, 8  
Literature: SARTSM, CROW, UTG1

DESCRIPTION

Diagonal constriction

MEASURE PAGE

TM70

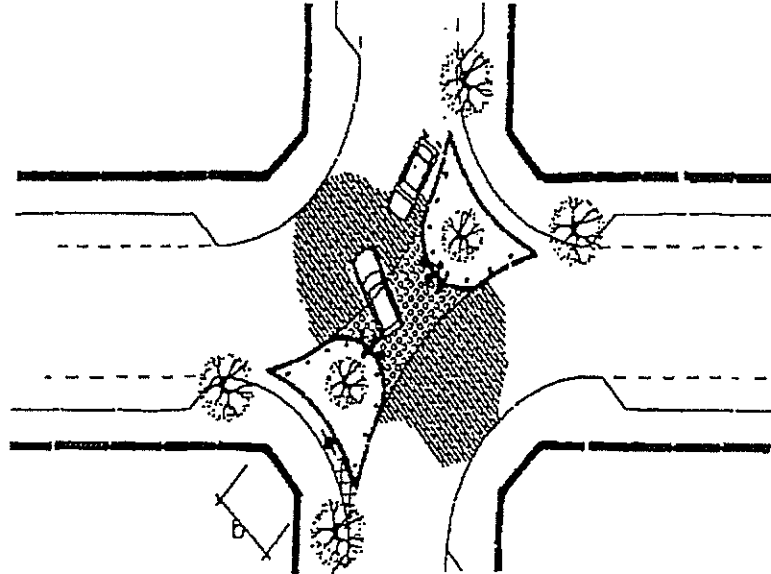
CONDITIONS FOR APPLICATION

- Peak hour volumes < 400 vph on each street
- 85th percentile speed < 60 km/h
- not on major road

IMPLEMENTATION

- ensure conspicuity with vertical elements and provide adequate lighting

POSITIVE ASPECTS

- good speed reduction
- visual relief without impeding sight distance

REMARKS:

Ref. Pages: SR1 - 4, 6, 8  
Literature: SARTSM, CROW, UTG1

DIMENSIONS

- $b \geq 1,5$  m, preferably 4 to 6 m
- width of cycle ways 1,35 m
- protrusions depend on manoeuvrability of design vehicle

ASSISTING MEASURES/  
POSSIBLE COMBINATIONSNEGATIVE ASPECTS

- situation is easily misjudged

DESCRIPTION

Passable traffic islands on intersection

MEASURE PAGE

TM71

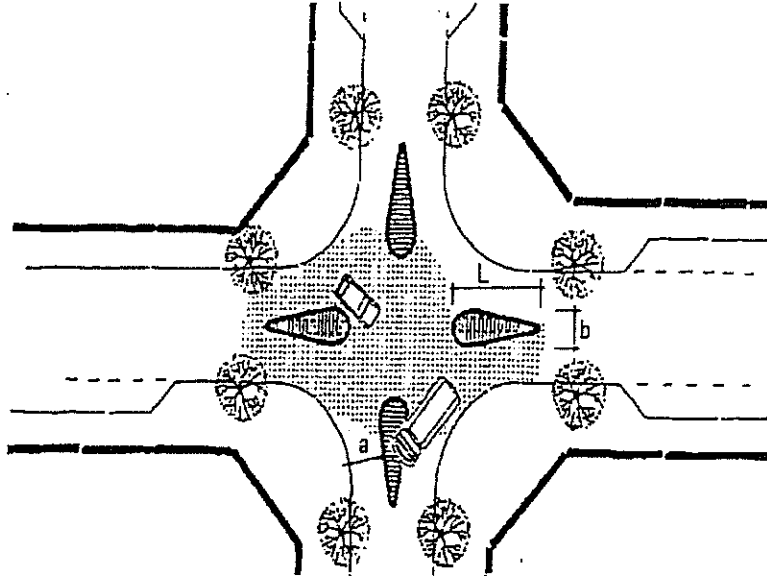
CONDITIONS FOR APPLICATION

- two-way traffic
- not on bus route, except where bus can avoid islands

DIMENSIONS

- $a = 2,75$  to  $3,25$  m
- $b \geq 1,5$  ( $1,0$ ) m
- $L = 5$  to  $6$  m
- design islands according to measurements needed for safe passing of motor vehicle

IMPLEMENTATION

- place islands in centre of roadway if possible
- diameter segment of circle
- islands paved in contrasting colour (white)

ASSISTING MEASURES/  
POSSIBLE COMBINATIONS

- vertical elements on islands, depending on manoeuvrability of design vehicle

POSITIVE ASPECTS

- moderate reduction in speed
- attention-getter for intersection

NEGATIVE ASPECTS

- difficult for buses and trucks to pass

REMARKS:

Ref. Pages: SR2, 8  
Literature: SARTSM, CROW

DESCRIPTION

Median at intersection

MEASURE PAGE

TM72

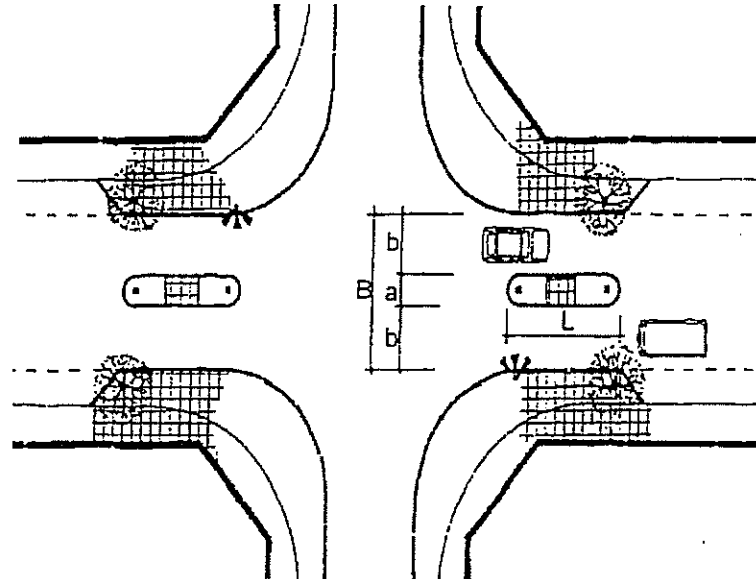
CONDITIONS FOR APPLICATION

- $B \geq 8,00$  m
- two-way traffic

DIMENSIONS

- $a \geq 3,25$  m
- $b \geq 1,50$  m
- $L = 5$  to  $10$  m
- dimensions depend on manoeuvrability of design vehicle. This may result in different measurements or/and asymmetrical placing of the median
- if  $L$  is large,  $a \geq 4,5$  m to enable blockages/breakdowns to be passed

IMPLEMENTATION

- place median in centre of roadway if possible
- ensure conspicuity with vertical elements and provide adequate lighting
- median not raised at pedestrian crossing
- for optional reduction of intersection surface: see TM66

ASSISTING MEASURES/  
POSSIBLE COMBINATIONS

- visual support: see SM9

POSITIVE ASPECTS

- road can be crossed in two stages
- easier to cross
- moderate speed reduction
- attention-getter for intersection

NEGATIVE ASPECTS

- for larger vehicles larger radii required
- little space on median
- decrease in parking space - 2 on each side

REMARKS:

Ref. Pages: SR2, 6, 8, Ped 2, 3, 4, 6, 7, 8, 10, 11, 12, 14, 15, 16 Appendix E)  
Literature: SARTSM, CROW, UTG1, Pedestrian Guidelines

DESCRIPTION

Mini-traffic circle

MEASURE PAGE

TM73

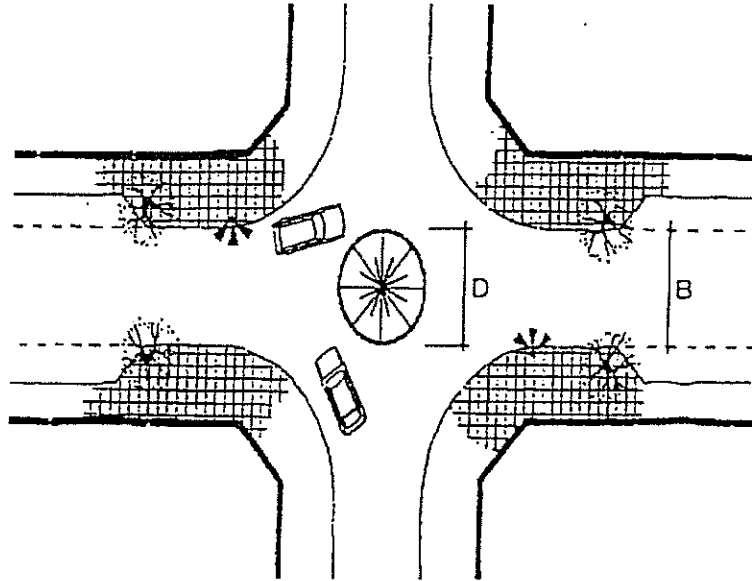
CONDITIONS FOR APPLICATION

- Peak hour volumes < 600 vph
- 85th percentile speeds < 60 km/h
- not on major road
- two-way traffic
- balanced flows

DIMENSIONS

- D preferably  $\geq$  B
- difference in levels 10 to 12 cm

IMPLEMENTATION

- where space is limited, use segment of circle with arrow, raised 10 to 12 cm
- where space is available, raise whole surface of circle
- construct deflection islands on approaches where appropriate

ASSISTING MEASURES/  
POSSIBLE COMBINATIONS

- physical support: see TM66
- visual support: see SM9
- speed humps
- pedestrian tables

POSITIVE ASPECTS

- good speed reduction
- attention-getter

NEGATIVE ASPECTS

- right turning traffic passes in front of the island

REMARKS:

Ref. Pages: SR2, 6, Ped 2, 6, 10, 14 (Appendix E)  
Literature: SARTSM, CROW, UTG1, RT83

Note: Mini-roundabouts are commonly used in South Africa and have been relatively favourably received. It is recommended that designs are independently assessed using engineering tools such as SIMTRA or ARCADY. More detailed geometric data would be developed for later versions of this method.

DESCRIPTIONMEASURE PAGE

Traffic circle

TM74

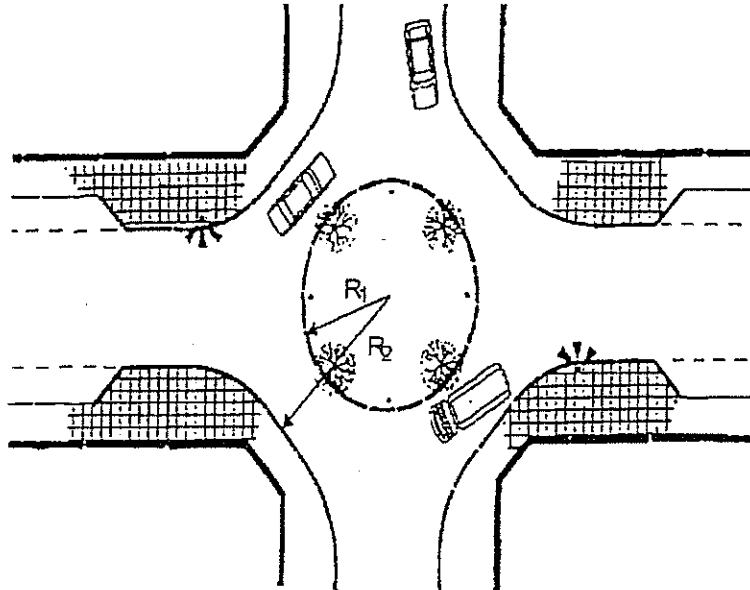
CONDITIONS FOR APPLICATION

- 85th percentile speeds < 60 km/h
- not on major road
- two-way traffic
- balanced flows

DIMENSIONS

- $R_1 > 6 \text{ m}$
- $R_2$  depends on manoeuvrability of design vehicle

IMPLEMENTATION

- vertical elements on traffic circle

ASSISTING MEASURES/  
POSSIBLE COMBINATIONS

- visual support: see SM9

POSITIVE ASPECTS

- good speed reduction
- visual break in intersection

NEGATIVE ASPECTS

- pedestrians have trouble judging traffic while standing on traffic circle
- cyclists use whole width of roadway
- high speed when turning left
- use a lot of space

REMARKS:

Ref. Pages: SR8, Ped 2,4, 6, 8, 10, 12, 14, 16 (Appendix E)  
Literature: SARTSM, CROW, UTG1

Note: These have been widely used in South Africa.

DESCRIPTION

Bayonet intersection

MEASURE PAGE

TM75

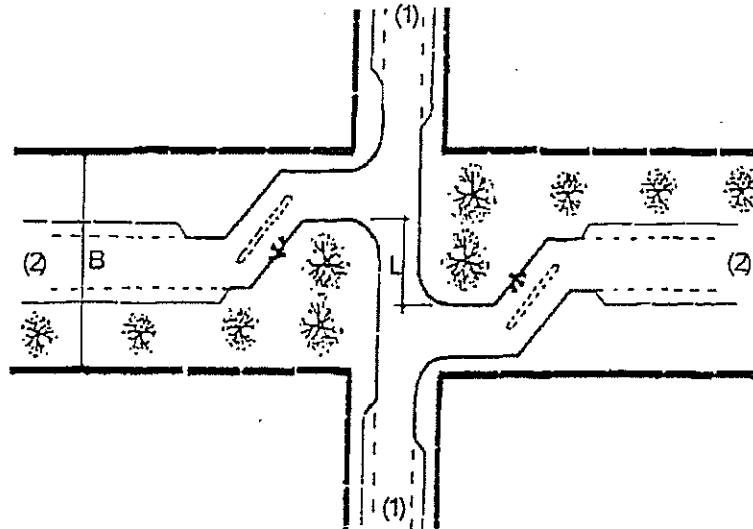
CONDITIONS FOR APPLICATION

- Peak hour volumes < 400 vph (2)
- 85th percentile speed < 60 km/h (2)
- not on cycle route (2)
- no bus and/or supply route on (2)
- $B \geq 30$  m

DIMENSIONS

- $L \geq 15$  m

IMPLEMENTATION

- ensure conspicuity with vertical elements and provide adequate lighting
- bayonet preferably on right

ASSISTING MEASURES/  
POSSIBLE COMBINATIONSPOSITIVE ASPECTS

- good speed reduction on (2)

NEGATIVE ASPECTS

- possible speed increase on (1)

REMARKS: Ref. Pages: SR3, 4, 8  
Literature: CROW, UTG1, SARTSM

DESCRIPTION

Entrance to speed reduced zone on intersection with  
exit constriction on side road

MEASURE PAGE

TM76

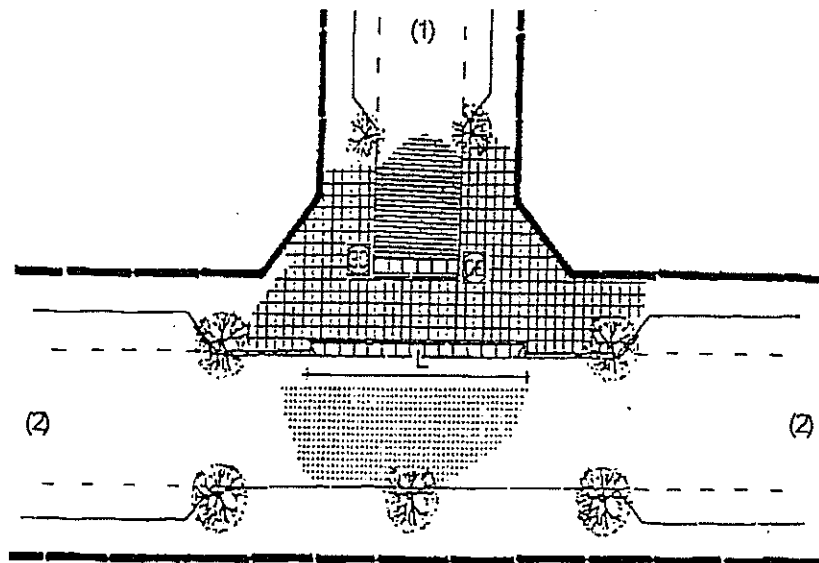
CONDITIONS FOR APPLICATION

- Peak hour volumes < 200 vph (1)  
< 700 vph (2)
- not on cycle route (1)
- no bus and/or supply route on (1)
- [(2) not on major road]

DIMENSIONS

- L depends on manoeuvrability of design vehicle and width of roadway on (2)

IMPLEMENTATION

- whole sidewalk paved in similar material
- ramps on both sides of the extended pavement
- for merging roadway (2) see TM86
- signing and marking (SARTSM)

ASSISTING MEASURES/  
POSSIBLE COMBINATIONSPOSITIVE ASPECTS

- very low entrance speed to reduced zone
- clear transition to reduced zone
- signs not necessary to explain priority areas/roads
- influence on route choice (discourages through traffic) as entrance is visible from (2)

NEGATIVE ASPECTS

- possible speed increase on (2)
- ramps inconvenient for cyclists

REMARKS: Ref. Pages: SR9  
Literature: SARTSM, CROW, UTG1



DESCRIPTION

Entrance to speed-reduced zone close to intersection  
(in principle) on side street

MEASURE PAGE

TM77

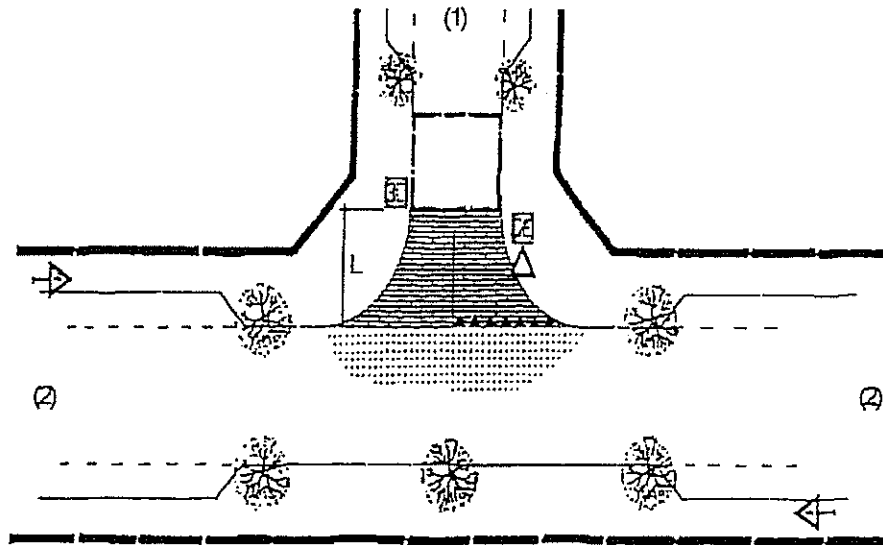
CONDITIONS FOR APPLICATION

- Peak hour volumes < 400 vph (1)  
< 700 vph on (2)

DIMENSIONS

- $L = 5$  to  $10$  m, depending on volumes in (1)

IMPLEMENTATION

- use speed reducing elements in area (TM-series, Chapter 8)
- ensure conspicuity with vertical elements and provide adequate lighting
- signing (SARTSM)
- (2) preferably a priority intersection or major road

ASSISTING MEASURES/  
POSSIBLE COMBINATIONSPOSITIVE ASPECTS

- moderate to low entrance speed, depending on implementation
- unmistakable transition to zone
- enough space between speed-reduced zone and (2)
- influence on route-choice (discourages through traffic) as entrance is visible
- can be used on cycle, bus, and/or supply routes

NEGATIVE ASPECTS

- possible increase in speed on (2)

REMARKS:

Ref. Pages: SR9  
Literature: SARTSM, CROW, UTG1

DESCRIPTION

Entrance to speed- reduced zone close to intersection, combined with buildings, arches, etc.

MEASURE PAGE

TM78

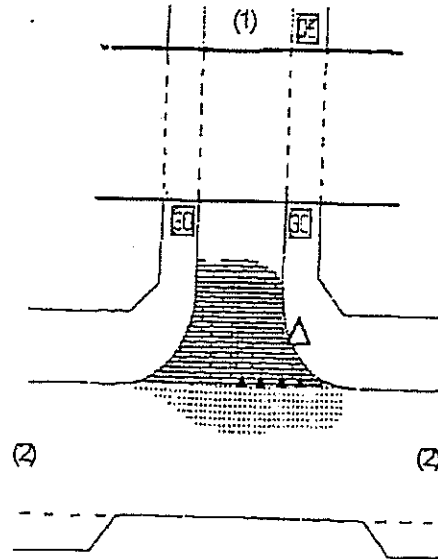
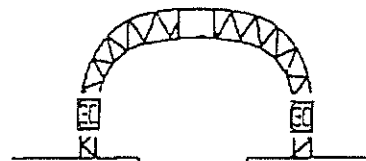
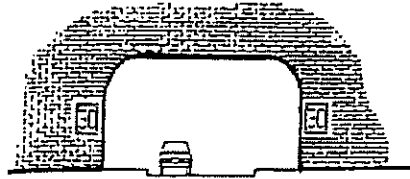
CONDITIONS FOR APPLICATION

- Peak hour volumes < 200 vph on (1)  
< 700 vph on (2)
- width of roadway (1)  $\geq$  6 m

DIMENSIONS

- clearance height:
  - motor vehicle - 2,6 m
  - bus - 3,7 m
  - truck - 4,2 (4,5) m

IMPLEMENTATION

- gateway can be constructed in different ways: buildings, timber constructions or trees
- signing (SARTSM)
- (2) preferably a priority intersection or major road if distance of gateway to (2)  $\geq$  10 m

ASSISTING MEASURES/  
POSSIBLE COMBINATIONSPOSITIVE ASPECTS

- unmistakable transition to zone
- exclusion of buses and trucks by clearance height
- influence on route choice (discourages through traffic) as entrance is visible from (2)

NEGATIVE ASPECTS

- possible high speed into the zone

REMARKS: Ref. Pages: SR9  
Literature: SARTSM, CROW, UTG1

DESCRIPTIONMEASURE PAGE

Entrance to speed-reduced zone on section of road

TM79

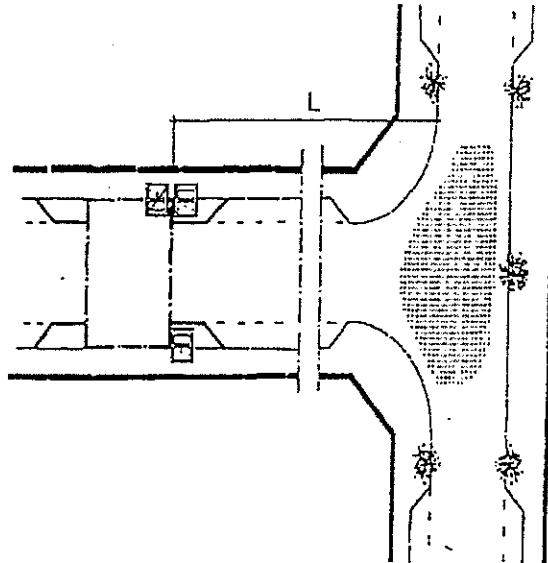
CONDITIONS FOR APPLICATION

- Peak hour volumes < 400 vph
- 85th percentile speeds < 60 km/h
- not on major road

DIMENSIONS

- $L$  (distance to intersection)  $\geq 30$  (20) m

IMPLEMENTATION

- use speed-reducing elements in area
- ensure conspicuity with vertical elements and provide adequate lighting
- signing

ASSISTING MEASURES/  
POSSIBLE COMBINATIONSPOSITIVE ASPECTS

- moderate to low entrance speed, depending on implementation
- unmistakable transition to zone
- can be used on cycle, bus and/or supply routes

NEGATIVE ASPECTS

- no influence on route choice

REMARKS:

Ref. Pages: SR9  
Literature: SARTSM, CROW, UTG1

DESCRIPTION

Entrance to speed reduced zone on section of road  
combined with deflection islands

MEASURE PAGE

TM80

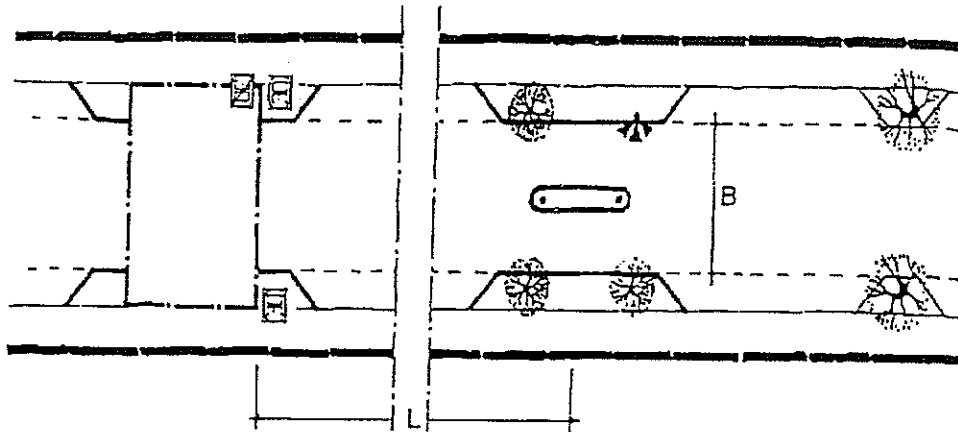
CONDITIONS FOR APPLICATION

- $B \geq 7$  m
- Peak hour volumes < 400 vph
- 85th percentile speeds < 60 km/h
- not on major road

DIMENSIONS

- $L = 30$  to  $50$  m
- median: see TM33

IMPLEMENTATION

- use speed reducing elements in area
- ensure conspicuity with vertical elements and provide adequate lighting
- signing

ASSISTING MEASURES/  
POSSIBLE COMBINATIONSPOSITIVE ASPECTS

- gradual reduction in speed when approaching entrance
- moderate to low entrance speed, depending on implementation
- unmistakable transition to zone
- can be used on cycle, bus and/or supply route

NEGATIVE ASPECTS

- no influence on route choice
- decrease in parking space: 2 to 3 on each side of road

REMARKS:

Ref. Pages: SR9  
Literature: SARTSM, CROW, UTG1

DESCRIPTION

Entrance to speed-reduced zone on section of road  
combined with change of direction

MEASURE PAGE

TM81

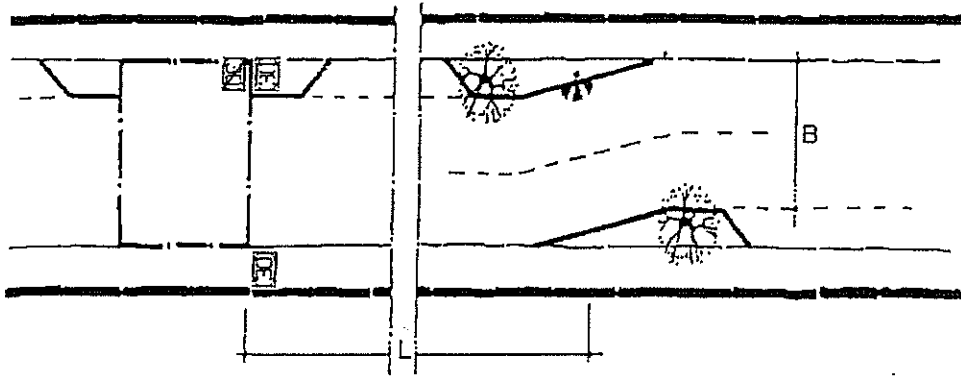
CONDITIONS FOR APPLICATION

- $B < 7$  m
- Peak hour volumes  $< 400$  vph
- 85th percentile speeds  $< 60$  km/h
- not on major road

DIMENSIONS

- $L = 30$  to  $50$  m
- gradient  $\geq 1:5$

IMPLEMENTATION

- use speed-reducing elements in area
- ensure conspicuity with vertical elements and provide adequate lighting
- signing

ASSISTING MEASURES/  
POSSIBLE COMBINATIONSPOSITIVE ASPECTS

- gradual reduction in speed while approaching entrance
- moderate to low entrance speed, depending on implementation
- unmistakable transition to zone
- can be used on cycle, bus and/or supply routes

NEGATIVE ASPECTS

- no influence on route choice
- crowding of cyclists
- decrease in parking space: 2 to 3

REMARKS:

Ref. Pages: SR9  
Literature: SARTSM, CROW, UTG1

DESCRIPTION

Entrance to speed-reduced zone on T-junction with exit construction on through road

MEASURE PAGE

TM82

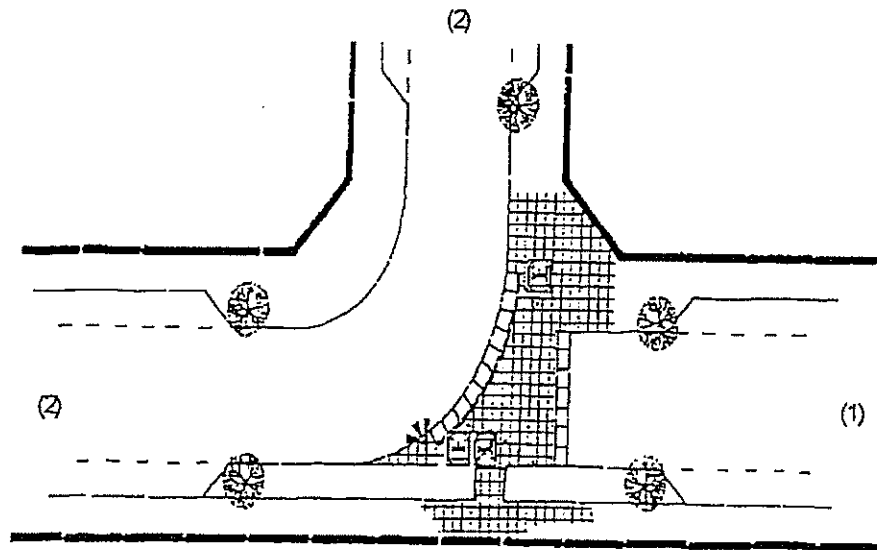
CONDITIONS FOR APPLICATION

- Peak hour volumes < 200 vph on (1)  
< 700 vph on (2)
- 85th percentile speed < 60 km/h
- not on major road
- not on cycle route
- not on bus and/or supply route

DIMENSIONS

- length of ramps or lowered kerb depends on manoeuvrability of design vehicle
- lowered kerb, gradient of sidewalk  $\geq 1:10$

IMPLEMENTATION

- ramps or lowered kerb on sides of roadway
- whole sidewalk paved in similar material
- no corner kerbs
- (1) should not look like a "woonerf"
- ensure conspicuity with vertical elements and provide adequate lighting
- signing

ASSISTING MEASURES/  
POSSIBLE COMBINATIONSPOSITIVE ASPECTS

- very low entrance speed to zone
- unmistakable transition to zone
- no signs necessary to explain priority areas/roads
- influence on route choice (discourages through traffic)

NEGATIVE ASPECTS

- ramps inconvenient for cyclists

REMARKS:

Ref. Pages: SR9  
Literature: SARTSM, CROW, UTG1

DESCRIPTION

Entrance to speed-reduced zone close to T-junction  
with turn-off

MEASURE PAGE

TM83

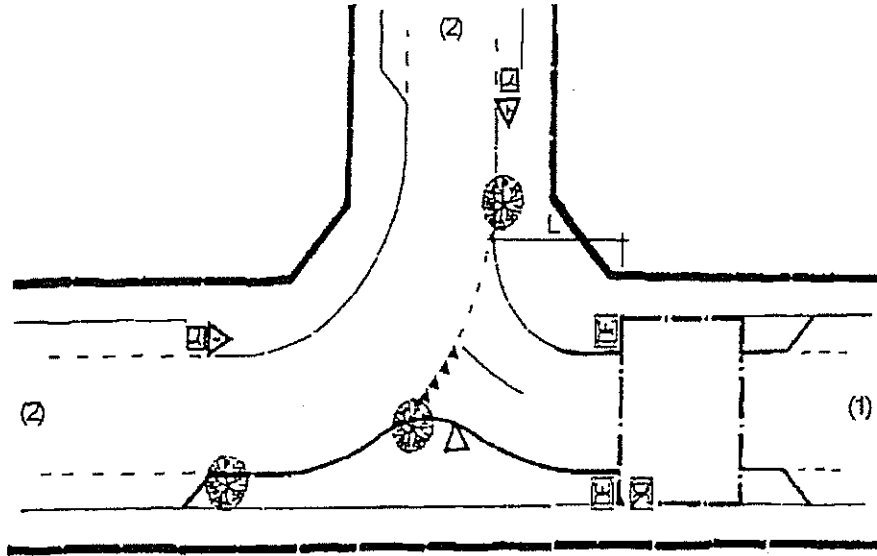
CONDITIONS FOR APPLICATION

- Peak hour volumes < 400 vph on (1)  
< 700 vph on (2)
- 85th percentile speed < 60 km/h
- not on major road

DIMENSIONS

- L = 5 to 10 m, depending on volumes in (1)

IMPLEMENTATION

- ensure conspicuity with vertical elements and provide adequate lighting
- (2) is thoroughfare
- (2) preferably a priority intersection or major road

ASSISTING MEASURES/  
POSSIBLE COMBINATIONSPOSITIVE ASPECTS

- moderate to low entrance speed to zone, depending on implementation
- unmistakable transition to zone
- enough space between 30 km/h zone and (2)
- influence on route choice (discourages through traffic) as gate is visible from (2)
- may be used on cycle, bus and/or supply route

NEGATIVE ASPECTS

- T-junction with reduced visibility

REMARKS:

Ref. Pages: SR9  
Literature: SARTSM, CROW, UTG1

DESCRIPTION

Entrance to speed-reduced zone on intersection  
combined with exit construction

MEASURE PAGE

TM84

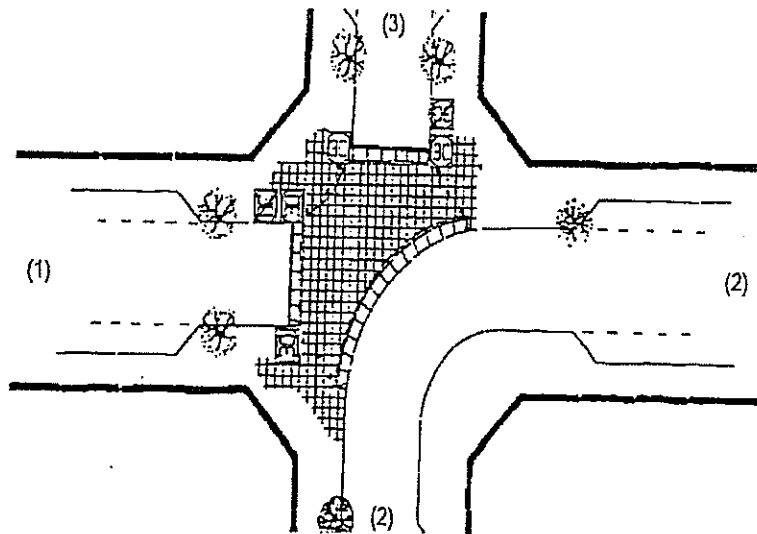
CONDITIONS FOR APPLICATION

- Peak hour volumes < 400 vph on (1) and (3)  
< 700 vph on (2)
- 85th percentile speed < 60 km/h
- not on major road
- not on cycle route
- not on bus and/or supply route

DIMENSIONS

- length of ramps or lowered kerbs depends on manoeuvrability of design vehicle
- with lowered kerb, gradient of sidewalk  $\leq 1:10$

IMPLEMENTATION

- ramps and/or lowered kerbs on the side of roadway
- whole sidewalk paved in similar material
- no corner kerbs
- (1) and (3) should not look like "wooner"
- ensure conspicuity with vertical elements and provide adequate lighting
- signing

ASSISTING MEASURES/  
POSSIBLE COMBINATIONSPOSITIVE ASPECTS

- very low entrance speed to zone
- unmistakable transition to zone
- influence on route choice (discourages through traffic) as entrance is visible from (2)

NEGATIVE ASPECTS

- reduced visibility at intersection
- ramps inconvenient for cyclists

REMARKS:

Ref. Pages: SR9  
Literature: SARTSM, CROW, UTG1



DESCRIPTION

Entrance to speed-reduced zone on intersection with diagonal constriction

MEASURE PAGE

TM85

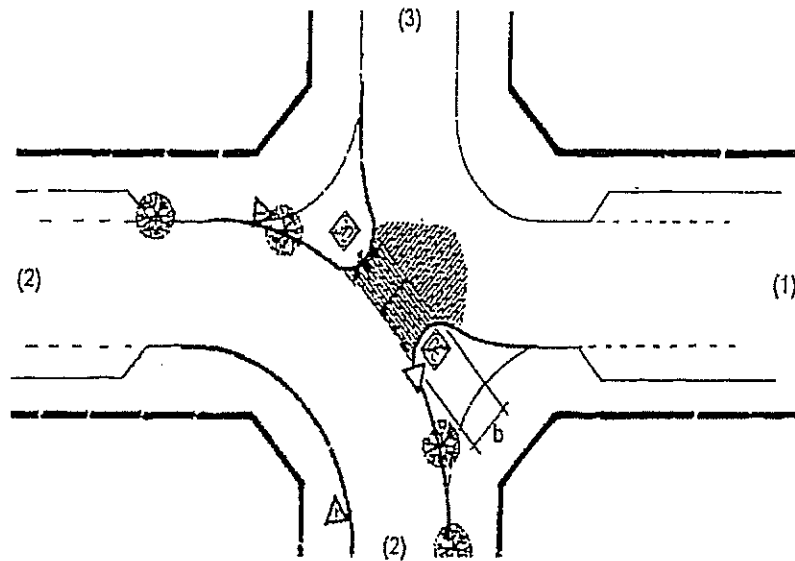
CONDITIONS FOR APPLICATION

- Peak hour volumes < 400 vph on (1) and (3)  
< 700 vph on (2)
- 85th percentile speed < 60 km/h
- not on major road

DIMENSIONS

- $b = 4$  to  $6$  ( $\geq 1,5$ ) m
- protrusions depend on manoeuvrability of design vehicle

IMPLEMENTATION

- ensure conspicuity with vertical elements and provide adequate lighting
- (1) and (3) with contrasting paving to (2)
- (2) as thoroughfare
- signing
- (2) preferably a priority intersection or major road

ASSISTING MEASURES/  
POSSIBLE COMBINATIONSPOSITIVE ASPECTS

- entrance speed to zone
- unmistakable transition to zone
- influence on route choice (discourages through traffic) as entrance is visible from (2)

NEGATIVE ASPECTS

- reduced visibility at intersection

REMARKS:

Ref. Pages: SR9  
Literature: SARTSM, CROW, UTG1

DESCRIPTION

Exit with ramp

MEASURE PAGE

TM86

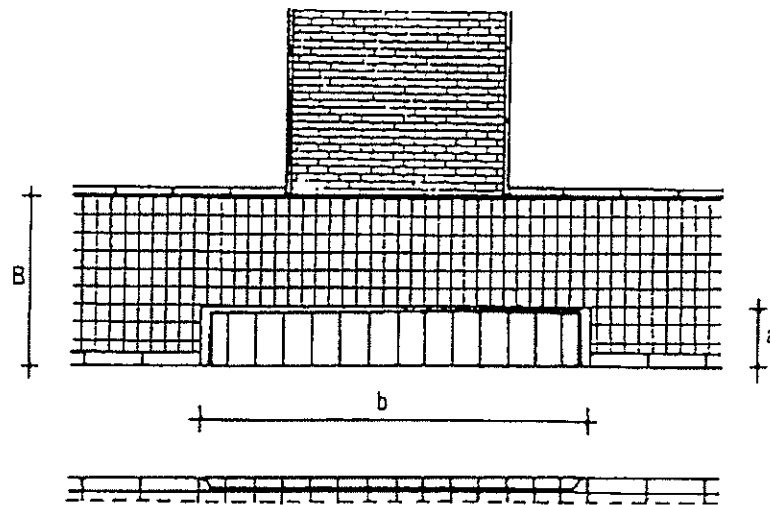
CONDITIONS FOR APPLICATION

- access to house, garage, private property or business premises from roadway; or
- merging of parking area, street or premises with the roadway of (another) street
- $B \geq 1 \text{ m}$

DIMENSIONS

- $a = 0,8 \text{ (0,5) m}$   
= 0,8 m at merging of street or premises
- $b = \text{variable}$

IMPLEMENTATION

- keep sidewalk and (if present) cycle way uniform in colour and surface
- with heavy traffic, adapt paving
- signs possible but not recommended
- construct ramp if merges with street
- no corner kerbs

ASSISTING MEASURES/  
POSSIBLE COMBINATIONS

- premises at back, or panhandle erven

POSITIVE ASPECTS

- clearly recognizable
- legal status clear
- clear boundaries to "no parking" area

NEGATIVE ASPECTS

- expensive
- ramps inconvenient for cyclists

REMARKS: Ref. Pages: Exits (6.1.2)  
Literature: UTG1

DESCRIPTION

Exit with corner elements or lowered kerb

MEASURE PAGE

TM87

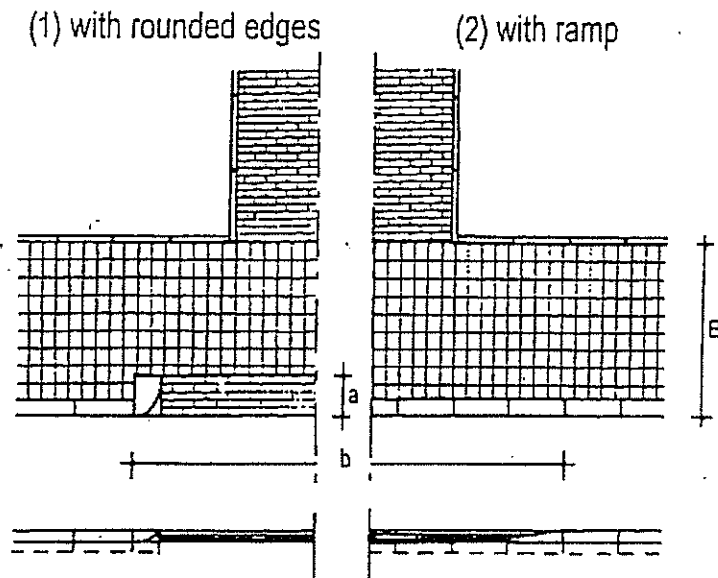
CONDITIONS FOR APPLICATION

- access to house or garage from roadway or access to clearly recognizable private property or business premises from road way with sidewalk

DIMENSIONS

- a = 0,5 to 0,8 m
- b = variable

IMPLEMENTATION

- keep sidewalk and (if present) cycle way uniform in colour and surface
- with heavy traffic, adapt paving
- gradient incorporated in paving
- where sidewalk is  $B \leq 1$  m, implement (2) by lowering whole sidewalk, difference in level phased out on both sides of access road
- signs possible but not recommended

ASSISTING MEASURES/  
POSSIBLE COMBINATIONSPOSITIVE ASPECTS

- inexpensive
- recognizable
- (1) clear boundaries to "no parking" area

NEGATIVE ASPECTS

- legal status unclear
- high maintenance (1)

REMARKS: Ref. Pages: Exits (6.1.2)  
Literature: UTG1, SARTSM, CROW

DESCRIPTION

Exit on uniform level

MEASURE PAGE

TM88

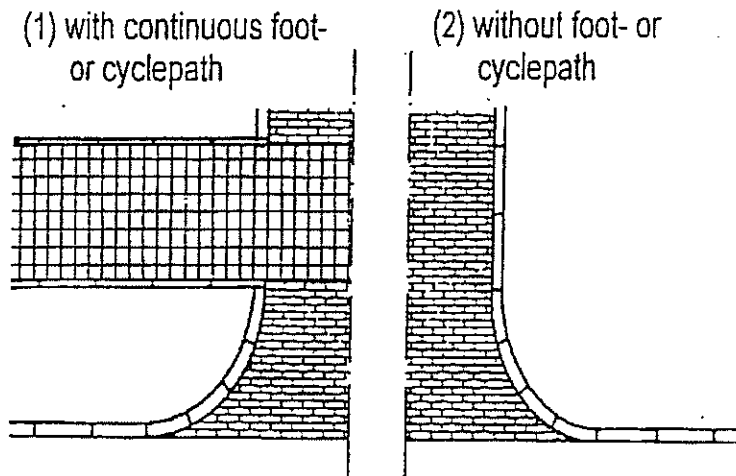
CONDITIONS FOR APPLICATION

- access to house or garage situated close to road, if clearly demarcated
- access to private property (shared access) or business premises from roadway or
- with heavy traffic and/or fragile loads
- side strip between roadway and pedestrian or cycle way present, if using (1)

IMPLEMENTATION

- if these are present, keep sidewalk and cycle way uniform in colour and surface (with heavy traffic, adapt paving)
- signs possible but not recommended

POSITIVE ASPECTS

- low maintenance

DIMENSIONS

- same as with normal intersection with roadway

ASSISTING MEASURES/  
POSSIBLE COMBINATIONSNEGATIVE ASPECTS

- not easily recognizable
- legal status unclear
- no clear boundaries for "no parking" area

REMARKS:

Ref. Pages: Exits (6.1.2)  
Literature: UTG1, SARTSM, CROW

---

## **SECTION IV: ACKNOWLEDGEMENTS AND REFERENCES**

---

### **CHAPTER 8: ACKNOWLEDGEMENTS**

The authors of the report thank the following persons and organisations for their valuable contribution to the compilation of this document:

- The Traffic Calming Guidelines Steering Committee:

Mr D J de Beer	-	Parow Municipality
Mr D F Havell	-	Johannesburg Metropolitan Council
Mr D Horne	-	CUTA/Port Elizabeth City Council
Prof. H S Joubert (Chairman)	-	Univ. of Pretoria/ African Consulting Engineers
Mr J C Krogscheepers	-	University of Natal
Mr F J J Labuschagne	-	Pretoria City Council/United Municipal Executive.
Mr T Malaza	-	Johannesburg Metropolitan Council
Mr G Oosthuizen	-	Centurion City Council
Mr G W Pascoe	-	Pietermaritzburg City Council
Mr E J Robertson	-	Western Cape Provincial Administration (initially)/ Ninham Shand Consulting Engineers
Mr R E Scholtz	-	Automobile Association of South Africa
Mr F C Swart	-	Alberton City Council
Prof. S C van As	-	University of Pretoria/ Consultant
Mr G J B van Rooyen	-	Germiston City Council
Mr H Visser/ Mrs J Kowalska	-	Department of Transport
Mr K M Wolhuter	-	CSIR/CUTA

- the dormant (do not participate at meetings) members of the committee:

Mr G Bruce	-	City of East London
Mr E Byker	-	City of Cape Town
Mr E Cornelius	-	South African Bus Operators Association
Mr D C Munro	-	City of Durban
Mr P Rabali	-	NAFTO
Mr M Rapodile	-	SABTA

- the various local authorities that provided information:
- Mr David Schermers and Mrs Woutje Bron for assisting with translations

## CHAPTER 9: REFERENCES

- AA ROAD SAFETY FOUNDATION. 1994. *Traffic Calming: Guidelines and warrants*, Pretoria, AA Road Safety Foundation.
- AFRICAN NATIONAL CONGRESS. 1994. *The Reconstruction and Development Programme - A policy framework*, Johannesburg, South Africa.
- BRINDLE, R E. 1991. *Traffic calming in Australia : A definition and commentary*. *Australian Road Research*, Volume 21, Number 2.
- COMMITTEE OF URBAN TRANSPORT AUTHORITIES. 1986. *Guidelines for the geometric design of urban arterial roads*, Draft UTG1, Roads and Transport Technology, Draft Urban Transport Guideline, UTG1, Pretoria, CSIR.
- COMMITTEE OF URBAN TRANSPORT AUTHORITIES. 1984. *Geometric design of rural roads*, Roads and Transport Technology, Technical Recommendations for Highways, Draft TRH17, CSIR.
- DEPARTMENT OF COMMUNITY DEVELOPMENT. 1983. *Guidelines for the provision of engineering services in residential townships*, Pretoria, Department of Community Development.
- DEPARTMENT OF TRANSPORT. 1993. *South African Road Traffic Signs Manual*, Pretoria, Department of Transport [Currently under revision].
- DEPARTMENT OF TRANSPORT. 1995. *Green Paper on National Transport Policy*, Pretoria, Department of Transport.
- White Paper on Reconstruction and Development, Notice 1954 of 1994. *Government Gazette*, Volume 353, No 16085.
- HASS KLAU, C; NOLD, I; BÖCKER, G and CRAMPTON, G. 1992. *Civilised streets - A guide to traffic calming*, Brighton, Environmental and Transport Planning.
- LINES, C J and Castelijn, H A.. 1991. *Translation of 30 kph zone design manual*, Crowthorne, Transport and Road Research Laboratory.
- National Housing Board. 1995. *Guidelines for the provision of engineering services and amenities in residential township development*, Division of Building Technology, Pretoria, CSIR.
- NATIONAL TRANSPORT COMMISSION. 1988. *Guidelines for the transportation systems management process*, Report PG3/88, Pretoria, Department of Transport.
- REPUBLIC OF SOUTH AFRICA. 1989. *The road traffic Act (No. 29) of 1989*, Pretoria, State President's Office.

- SOUTH AFRICAN BUREAU OF STANDARDS. 1992. *Traffic Signal Controllers*, SABS Standard Specification: SABS 1547: 1992, Report GR2, Pretoria, SABS.
- SOUTH AFRICAN INSTITUTION OF CIVIL ENGINEERS. 1981. *Guidelines on the planning and design of township roads and stormwater drainage*, (2nd edition), SAICE, Johannesburg.
- SOUTH AFRICAN ROADS BOARD. 1987. *Guidelines for the planning and design of pedestrian facilities*, SARB, Report PG3/87, Pretoria, Department of Transport.
- SOUTH AFRICAN ROADS BOARD. 1985. *Parking Standards*, (2nd edition), SARB, Report PG 3/85, Pretoria, Department of Transport.
- SCHERMERS, G. 1987. *Roundabouts - An alternative intersection control*, Roads and Transport Technology, Technical Report RT83, Pretoria, CSIR.
- SCHERMERS, G. 1994. *Atterbury road investigation*, Division of Roads and Transport Technology, PREMET Project Report DPVT/C291, Pretoria, CSIR.
- STICHTING CENTRUM VOOR REGELGEWING EN ONDERZOEK IN DE GROND-, WATER- EN WEGENBOUW EN DE VERKEERSTECHNIEK. 1988. *ASVV aanbevelingen voor verkeersvoorzieningen binnen de bebouwde kom*, (3rd edition), Ede, CROW.
- US DEPARTMENT OF TRANSPORTATION. 1985. *Highway Capacity Manual*, Transportation Research Board, Washington, Federal Highway Administration.
- VAN AS, S C and JOUBERT, H S. 1990. *Traffic flow theory*, SARB Chair in Transportation Engineering, Pretoria, University of Pretoria.
- WHITELEGG, J. 1991. *The future of urban transport*, Australian Road Research, Volume 21, Number 2.

---

## ***SECTION V: APPENDICES***

---

### **APPENDIX A : GEOMETRIC DESIGN CRITERIA**

#### **1 DESIGN ELEMENTS**

This chapter draws extensively from relevant material in UTG1 (CUTA 1986) and CROW (1988).

##### **1.1 Human environment factors**

Traffic calming aims at restoring the quality of life within the residential environment by mitigating the negative effects of traffic. The designer should therefore take account of the capabilities and limitations of all road users. The following section is an extract from work conducted by CROW (1988) in the Netherlands.

Road users generally have one principal aim, namely reaching a selected destination. In order to achieve this, certain recurring thought processes, in interaction with the environment, take place. These are observation, evaluation, decision and action. The human can thus be described as an information processing system which bases decisions on three levels, each of whose information processing cycles occur in a different timescale. These levels are:

- **Strategic** - These are the decisions underlying issues affecting route planning, choice and following. This function is performed consciously and the frequency of repeating the information processing cycle is low.
- **Manoeuvre** - This relates to the execution of decisions taken at the strategic level. The execution of manoeuvres, in relation to the road (turning off, etc.) and other to road users (overtaking, yielding, avoiding pedestrians etc.), is partially conscious and to an extent automatic (i.e. done without thinking). The time scale between successive decisions is anything between one second and tens of seconds.
- **Operational** - This is the lowest level of decision making and is influenced by decisions at higher levels. To a large extent execution is automatic with a high frequency of repetitiveness. These actions include steering the vehicle and controlling its speed.

Human ability to process information is limited and often the rate at which stimuli are received exceed the rate at which the information can be processed. However, in such instances, humans apply a system of selection and reduction, amongst others by testing specific expectations against possible consequences. On the other hand, an inadequate supply of information from the environment may result in a loss of concentration. It is therefore essential to balance the



supply of information requiring decisions against the ability of the user to make the correct decision based on that information.

Obviously the selection and processing of information takes time and account should be taken of the minimum reaction time (the time from observation to action), which is typically between 1,5 and 2,5 seconds. If the supplied information does not correspond with the expectation, then this time increases. Reaction time is also dependent on age.

The extent to which these processes are executed in a correct manner therefore depends on:

- the ability to observe, judge, decide and act;
- knowledge and insight;
- skills; and
- motivation.

The above can be influenced by one or a combination of the following:

- age;
- physical handicaps;
- task complexity;
- level of training or experience;
- fatigue; and
- use of alcohol, medicines and/or drugs.

The predominant sensory input of the road user in interacting with the road environment and traffic is visual acuity. Hearing, balance and tactile senses play a far lesser role. Based on the characteristics of the human information processing system, along with its limitations, there are a number of factors which shall be common to all information carriers (i.e. those tools used to convey messages including signs and markings, alignment, signals etc.). These common factors include:

- **Visibility** - the size of the lettering on the information carrier should be such as to ensure that the message is visible under all conditions;
- **Conspicuity** - Colour plays an important role and the message should not disappear against the background;
- **Recognisability** - the information given should be recognisable and be linked to the message receiver's knowledge; and
- **Understanding** - the information should link up with the knowledge and experience of the road user so as to allow him to make decisions regarding the information and to provoke the correct reaction under the given circumstances.

Over and above these human factors, one should remember that there are social aspects related to traffic and road infrastructure. The designer should not lose sight of the negative impacts that these can have on the social environment and social relations. To a large extent it is these impacts that have created the need for traffic calming.

There are four elements impacting on the social environment which the designer should always bear in mind during the planning process. These are :

- **Mobility and accessibility of destinations**

Mobility can be defined as the total opportunities that an individual has to shift or move himself (CROW, 1988). There is also a question of ethics linked to this, namely which opportunities should be offered to the individual and which can be denied. A social aspect of this is the guarantee that there would be a sufficient degree of mobility for all population groups.

Accessibility is defined as the total opportunities that an individual has to reach a certain destination. During the planning and design phases, account should be taken of accessibility to different destinations for different population groups, whilst at the same time mitigating the possible negative impacts on surrounding residents.

Examples of accessibility include:

- accessibility of shops and public buildings to the elderly and handicapped;
- accessibility of nursery schools and play parks to young children; and
- accessibility of schools and sport facilities to scholars.

- **Social safety and security**

This is the provision of a safe environment and a feeling of safety/security. This is especially important on pedestrian and cycle routes and also at modal transfer centres, taxi ranks and bus stops. The designer should, where possible, try and incorporate the following aspects into the design:

- make pedestrian and cycle routes, bus stops etc. highly visible;
- provide adequate and well located lighting;
- ensure the presence of housing in the vicinity of such facilities (social controls);
- avoid sudden, unexpected turns and corners in the alignment; and
- make provision for alternative night time routes.

- **Segregation and disruption of society**

High order roads (with an important traffic function) through residential areas have a major impact particularly on child play and on informal relationships within that area. This can result in a loss of mobility options of these residents, causing less social contact, tendency to limit going out, influences choice of school etc. The interaction between relationships in the area and the environment, road and traffic characteristics should be clearly understood in order to allow mitigatory measures to be incorporated in the planning and design stages.

- **Forced migration**

The provision of new infrastructure often implies land expropriation. This in itself may cause residents (both those directly and indirectly affected) to relocate to other areas. The extent to which this could occur depends largely on the affluence of the affected society.

## 1.2 The driver

For the use of this guideline the recommended driver eye height and reaction times set out in UTG1 (1986) and TRH 17 (1984) are adopted.

Research has shown that 95 per cent of passenger car drivers have an eye height at or above 1,05 metres, compared to 95 per cent of truck drivers with an eye height of over 1,8 metres.

The reaction time to a single stimulus has been adopted as 2,5 seconds in South Africa.

## 1.3 Vehicle factors

In the design of road infrastructure, the characteristics of the vehicles that would be making use of these facilities should be taken into account. For this purpose a design vehicle is used and therefore the dimensions and other characteristics of this vehicle should be known in order to facilitate appropriate intersection and road designs in the urban environment. With traffic calming, however, the objectives of the specific project should be incorporated in the design (e.g. access restriction for HGVs, speed restriction of 30 km/h etc.). It is therefore important to ensure that the proposed designs can accommodate the traffic that would be using the facility. A number of vehicle factors will impact on the geometric design of proposed schemes. The majority of these are well documented. The following have been extracted from UTG1 (1986).

### 1.3.1 The design vehicle

Dimensions for passenger cars (P) have been established in South Africa and the single-unit truck (SU) is the subject of the study. Dimensions have been tentatively established for buses but these are subject to review. Where dimensions were unavailable, the dimensions of the American design vehicle have been applied.

The typical design vehicle for urban class 5 roads (i.e. those applicable to traffic calming) is the passenger car. However, due regard should be given to other vehicles (such as buses, delivery vehicles etc.) should these make use of these roads. The designer should therefore ensure that turning radii at intersections accommodate such vehicles.

Designs are not usually based on the maximum or minimum values of the characteristics as they appear. The norm is to design for the 85th or 15th percentile of that specific vehicle (i.e. 85 per cent exceed that limit whereas 15 per cent are below that limit).

Dimensions for the various design vehicles are shown in Table A.1.

Table A.1: Dimensions of design vehicles				
Vehicle	Wheel Base (m)	Front overhang (m)	Rear overhang (m)	Width (m)
Passenger car (P)	2,85	0,75	1,20	1,80
Single unit truck (SU)	6,10	1,22	1,83	2,50
Single unit + trailer (SU +T)	6,7 +3,4 <u>+6,1</u> 16,2			
Single unit bus (BUS)	6,00	2,50	3,50	2,60
Articulated bus (ABUS)	5,49 <u>+7,32</u> 12,81	2,44	3,05	2,60
Semi-trailer (WB-50)	6,10 <u>+9,15</u> 15,25	0,92	0,61	2,50

Note : Maximum in South Africa  
Source : UTG1(1986)

### 1.3.2 Turning templates

The use of templates is recommended for establishing intersection layouts and median openings. Furthermore, to ease construction, it is recommended that, upon establishing roadway edges, these be approximated by simple or compound curves. Figures A.1 and A.2 give dimensions for the construction of templates for passenger cars, single units and articulated trucks.

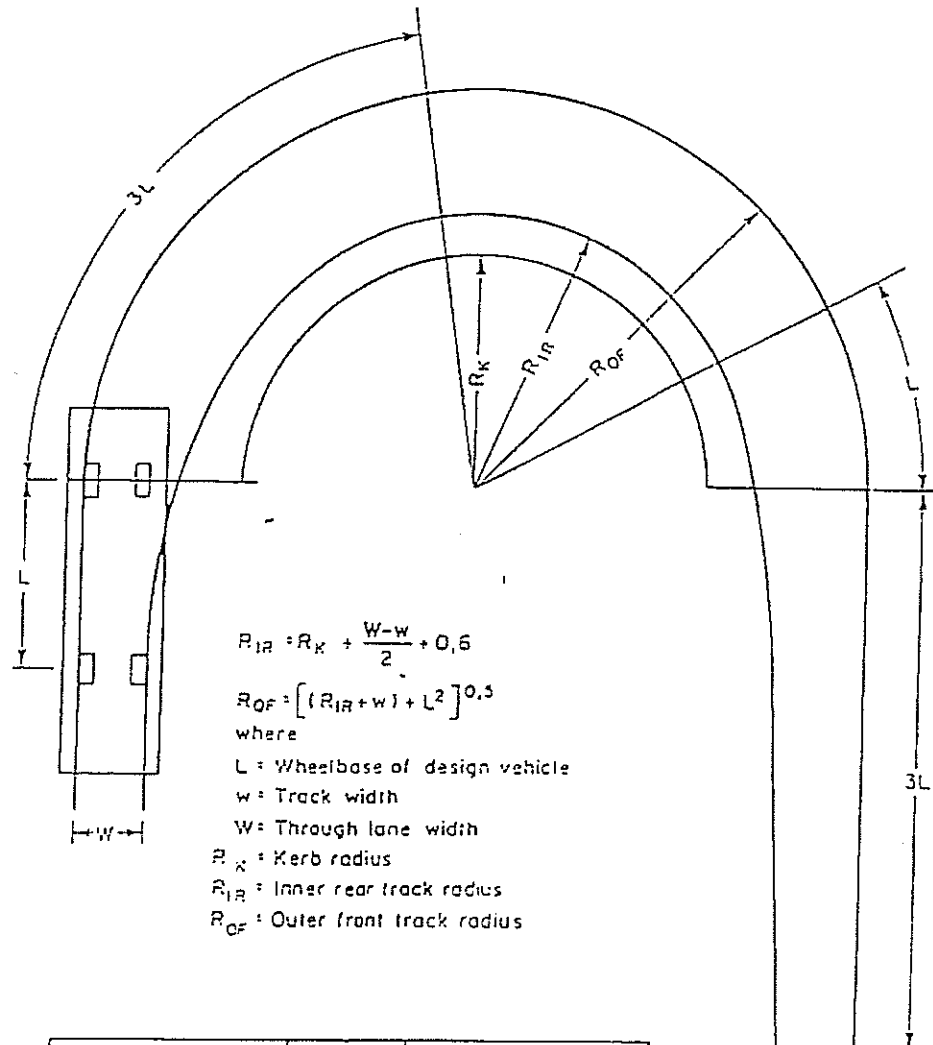

DESIGN VEHICLE	L	W	$R_{OF}$ FOR W = 3,7 AND $R_k =$			
			15	20	30	45
PASSENGER CAR	2,85	1,8	19,5	23,5	33,4	49,4
SINGLE UNIT TRUCK	6,10	2,5	19,6	24,4	34,2	49,0
BUS	5,00	2,6	19,5	24,4	34,2	49,1

Dimensions in metres

Figure A.1 : Wheel tracks of rigid chassis vehicles

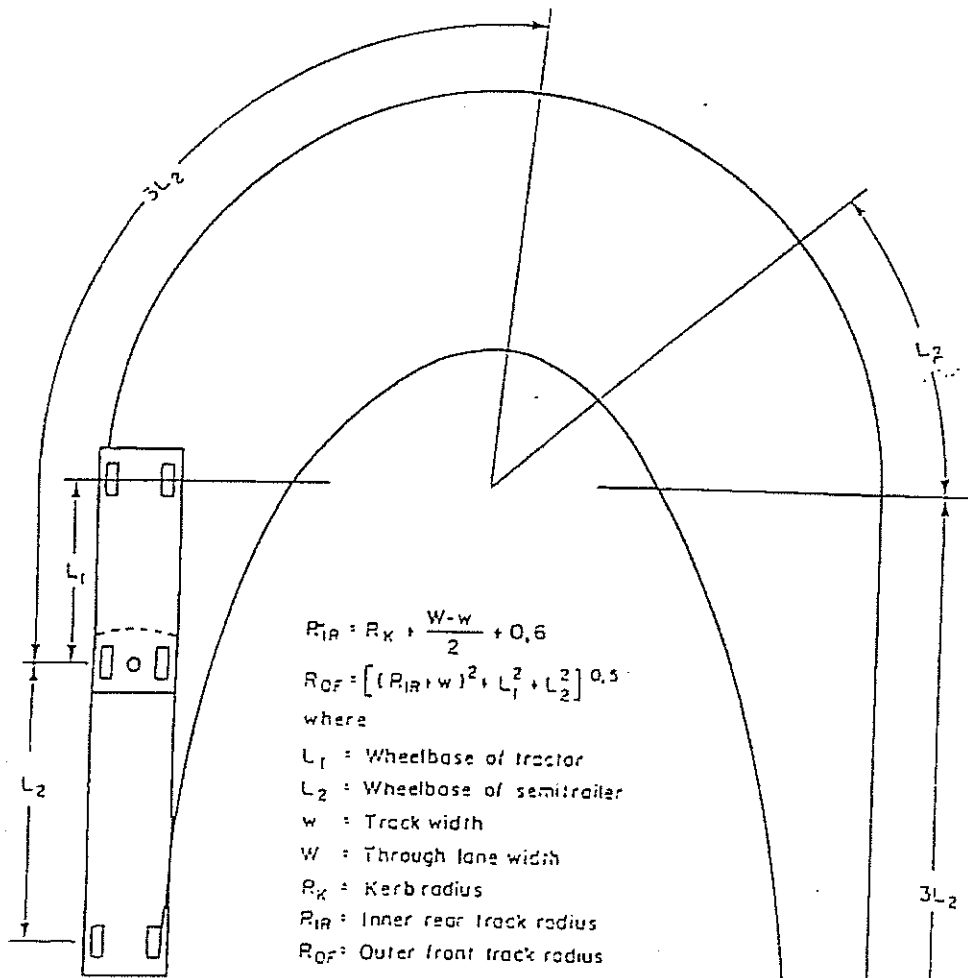

DESIGN VEHICLE	$L_1$	$L_2$	$w$	$R_{OF}$ FOR $w = 3,7$ AND $R_{IR} =$			
				15	20	30	45
ARTICULATED BUS	5,49	7,32	2,6	20,9	25,5	35,0	48,6
SEMI-TRAILER WB 50	6,10	9,15	2,5	21,5	25,1	35,4	49,9
SU TRUCK AND TRAILER	10,60	6,10	2,5	22,3	25,5	35,8	50,2

\* L = Measured to front wheels of trailer

Dimensions in metres

Figure A.2 : Wheel tracks of articulated vehicles

### 1.3.3 Minimum turning radius

In situations where templates are inappropriate, the capabilities of the design vehicle become critical. It is therefore suggested that the minimum turning radii shown on Table A.2 be used. It is stressed that these radii are for the outer side of the vehicle body and are appropriate only to crawl speeds.

Vehicle	Min. turning radius (m)
Passenger car	6,20
Single unit	12,81
Single unit plus trailer	14,00
Single unit bus	13,10
Articulated bus	11,59
Semi-trailer	13,72

Source : UTG1 (1986)

### 1.3.4 Performance on grade

The use of traffic calming measures is not recommended in cases where gradients exceed 5 per cent. However, the effect of gradient on truck speeds is shown on a single family of curves in Figure A.3.

### 1.4 The road surface

The road surface has numerous qualities which may affect the driver's perception of the conditions ahead of him. Skid resistance is the only one of these qualities that is discussed in these guidelines.

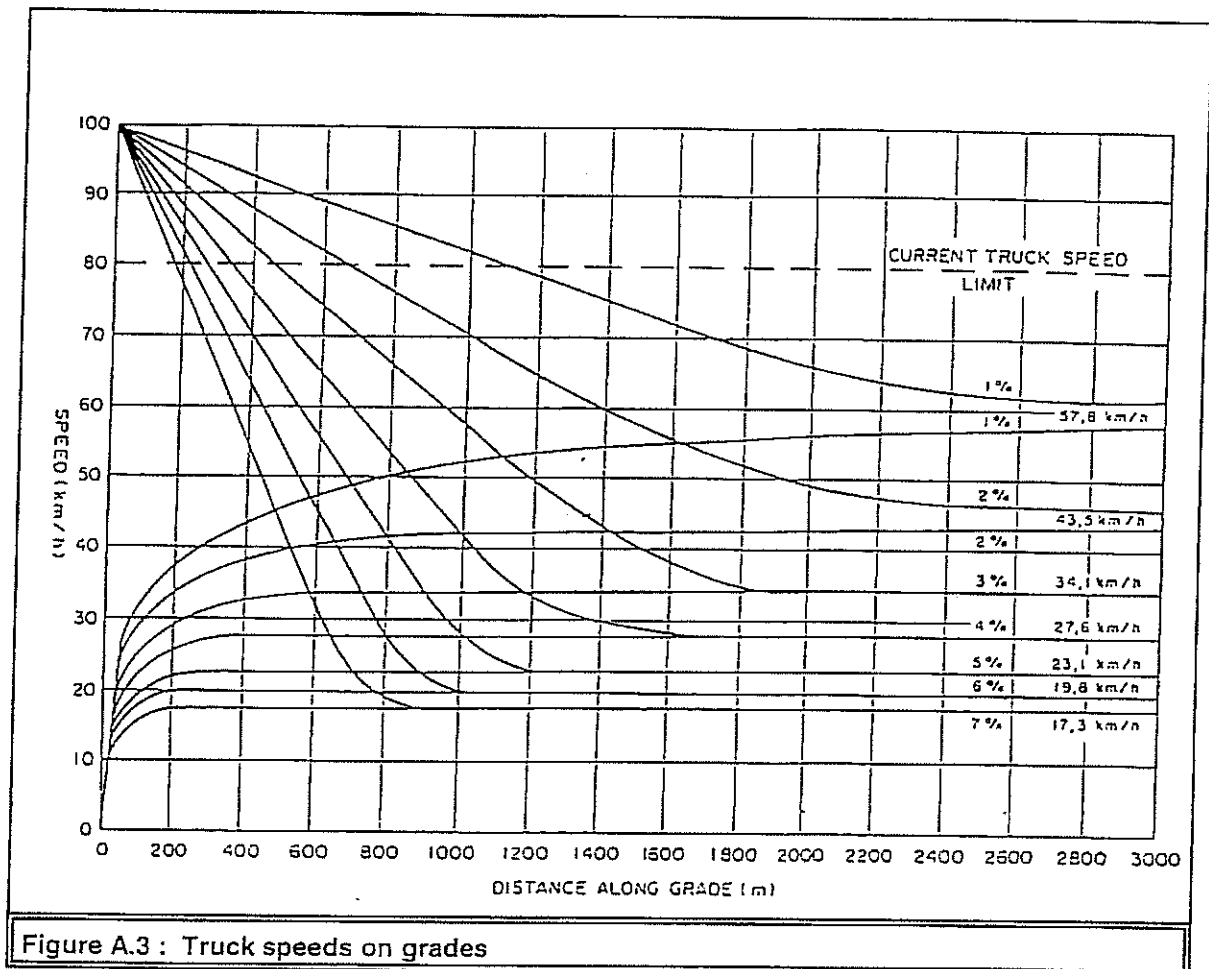

Figure A.3 : Truck speeds on grades

#### 1.4.1 Skid resistance

It has been locally established that the derived values (from worldwide research) of brake force coefficient are appropriate to the South African environment. These values range considerably, for example at 50 km/h and 100 km/h the skid resistance of a worn tyre on a smooth surface is one half and one fifth of that of a rough surface respectively. Skid resistance is dependent on speed and increases as speed decreases.

The values adopted in this guideline are based on those in UTG1 (1986). They are conservative and the speed used in the calculation of the guideline values is the operating speed, generally 80 to 85 per cent of the design speed.

Brake force coefficients are shown on Table A.3. These do not allow for a safety factor and represent actual measured values for a worn tyre on a smooth, wet surface, constituting in engineering terms the worst case. In addition, the coefficient of friction is lower in sliding than in rolling, so that, as long as the driver is not involved in an emergency situation, he has adequate distance to bring the vehicle to a comfortable stop under normal conditions.



Speed (km/h)	Brake force coefficient
40	0,37
60	0,32
80	0,30
100	0,29
120	0,28

Source : UTG1 (1986)

### 1.5 Sight distance

Sight distance is a fundamental element in the design of any road (both urban and rural). It is imperative that a driver is able to perceive hazards on the road and to have sufficient time in hand to initiate any necessary evasive action safely. On two-lane two-way roads, it is also necessary for him to be able to enter the opposing lane safely while overtaking. In the design of intersections the application of sight distance differs slightly from that of an open road. However, safety is always the primary consideration.

#### 1.5.1 Stopping sight distance (SSD)

Stopping sight distance involves the capability of the driver to bring his vehicle safely to a standstill. It is thus based on speed, driver reaction time and skid resistance. The total distance travelled in bringing the vehicle to a stop comprises two components, namely:

- the distance covered during the driver's reaction period; and
- the distance required to decelerate to 0 km/h

The stopping sight distance is expressed as:

$$s = 0,694v + v^2/254 f$$

where :

s = total distance travelled (m)

v = speed (km/h)

f = brake force coefficient

Stopping sight distance based on operating speeds and the appropriate brake force coefficients (Table A.3) have been adopted for design.

Design speed (km/h)	SSD (m)
40	50
50	65
60	80
70	95
80	115

Source : UTG1 (1986)

Stopping sight distance is measured from an eye height of 1,05 m to an object with a height of 0,15 m. This object height is used because an obstacle of less height would not usually represent a significant hazard. Object height is taken into account because measurement of the sight distance to the road surface would substantially increase the length of vertical curves and, consequently, the amount of earthworks required.

Gradient affects the stopping sight distance requirements (Table A.4). Figure A.4 is an expansion of the values shown in Table A.4 and demonstrates the effect.

Gradient (G) modifies the stopping sight distance formula to :

$$S = 0,694v + v^2/254 (f \pm G) \text{ (Ref UTG1, 1986)}$$

where G is the per cent grade divided by 100

AASHTO assumes v to be equal to design speed for downgrade conditions to be equal to running speed (less than design speed) for upgrade conditions. UTG1 (1986) shows values of stopping sight distance on grades, with built-in assumptions that operating speeds are less than design speed when road surfaces are wet.

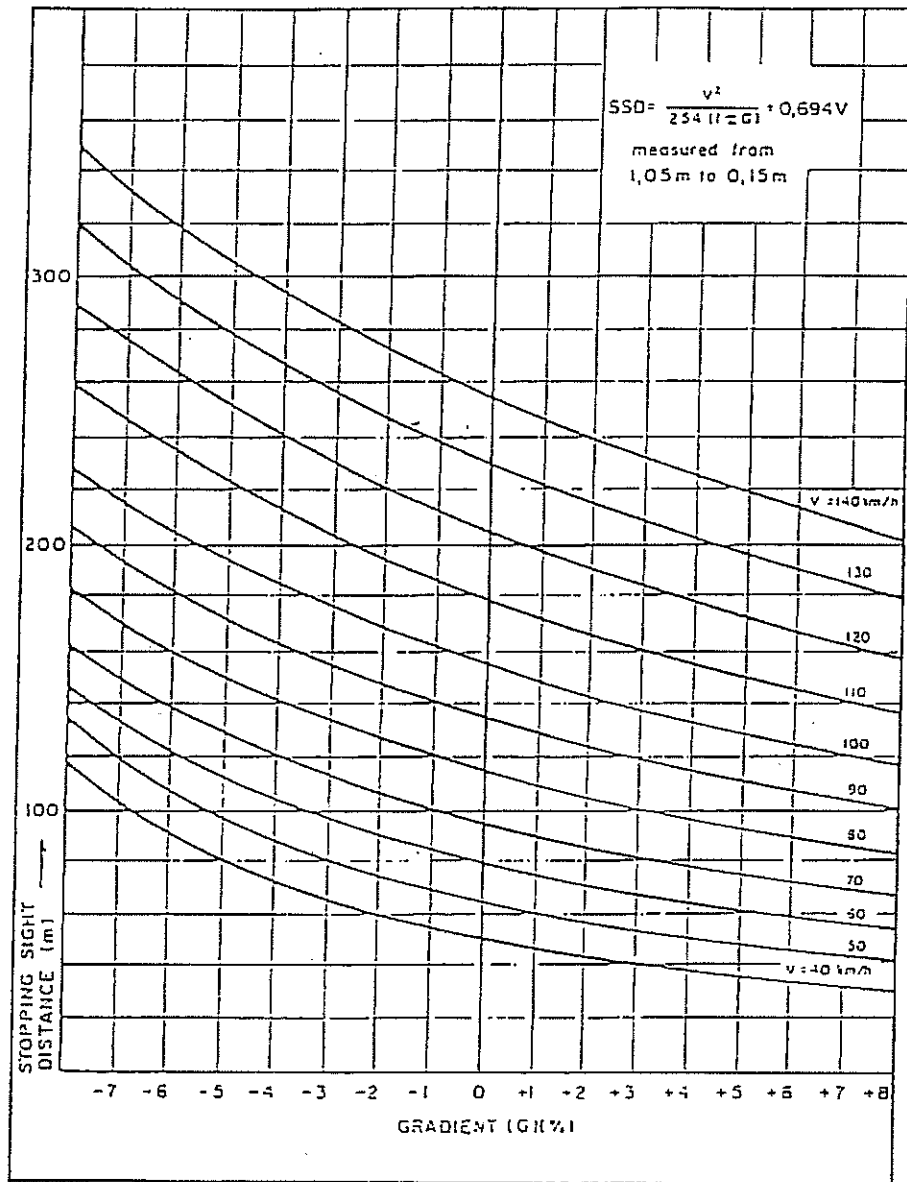

Figure A.4 : Stopping sight distance on grades (UTG1, 1986)

Stopping sight distance may also be affected by visual obstructions (e.g. cut slope or wall) next to the carriageway on the inside of a horizontal curve (Figure A.5).

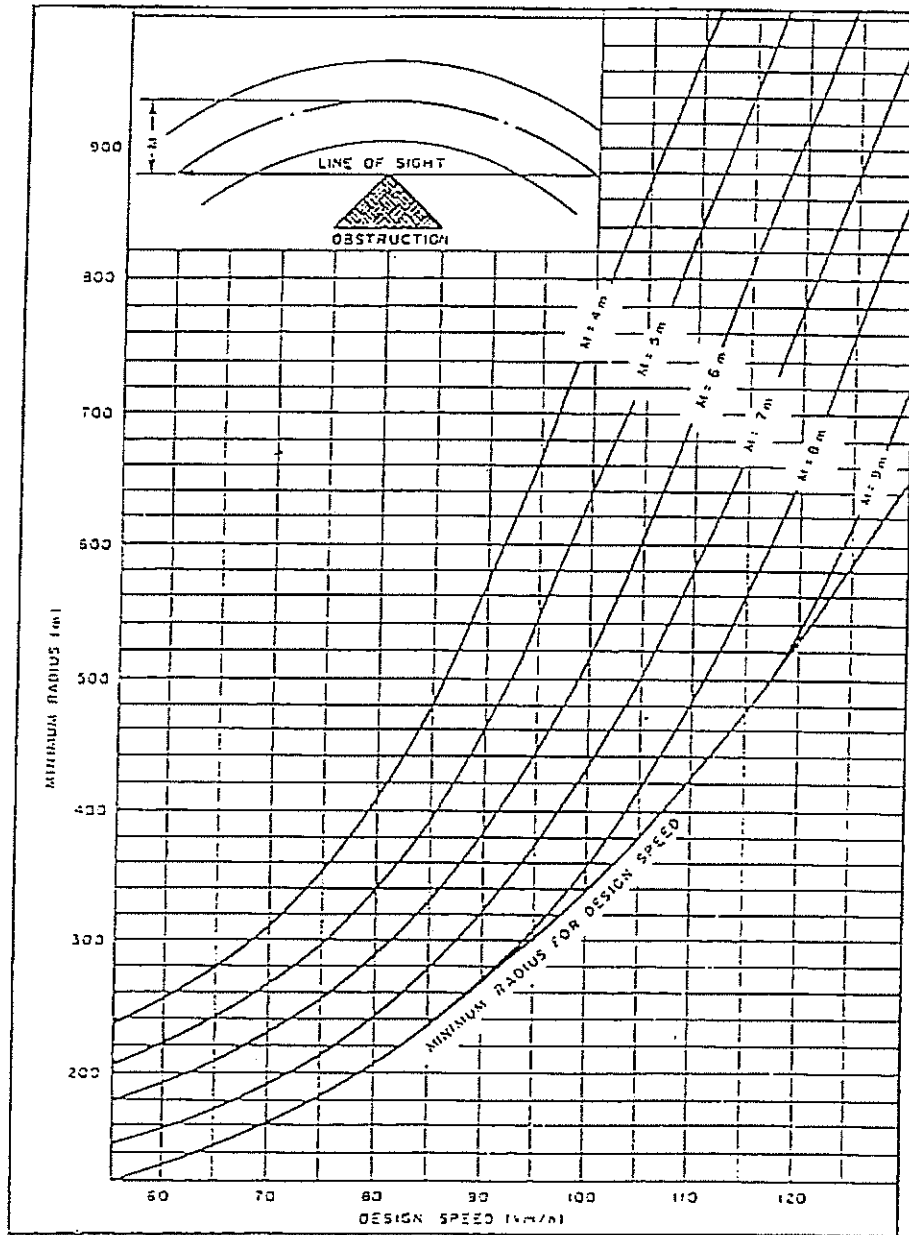

Figure A.5: Horizontal radius for stopping sight distance (UTG1, 1986)

### 1.5.2 Barrier Sight Distance (BSD)

Barrier sight distance is the limit below which overtaking is legally prohibited. Two vehicles travelling in opposite directions in the same lane should be able to stop before impact. A logical basis for the determination of the barrier sight distance is therefore that it should equal twice the stopping distance. The South African Road Traffic Signs Manual (SARTSM, 1993) gives values that approximate this approach (see Table A.5).

Design speed (km/h)	BSD (m)
50	150
60	180
80	250

Source : UTG1 ( 1986)

Barrier sight distance is measured to an object height of 1,3 m and eye height remains at 1,05 m. The increased object height is realistic since it is approximately that of a low, approaching vehicle.

### 1.5.3 Decision sight distance (DSD)

The most effective visual aid to the driver is the view of the road ahead. In certain circumstances it is necessary for the road surface to be visible to the driver for a given distance ahead. This is to allow the driver adequate time to safely assimilate, interpret and react to any given message (e.g. lane markings on approaches to intersections need sufficient advance warning to allow for lane changes without detrimentally affecting intersection operation).

Table A.6 provides decision sight distances as related to the reaction time involved with complex driving tasks. In this case the object height is zero (i.e. the road surface), the eye height remaining 1,05 m.

Table A.6 : Decision sight distance on level roads	
Design speed (km/h)	DSD (m)
40	130
50	160
60	190
70	215
80	240

Source : UTG1 (1986)

#### 1.5.4 Passing sight distance (PSD)

Passing sight distance in design is based on the length required to complete normal passing manoeuvres safely. For practical purposes this is based on a single vehicle passing another single vehicle. Longer sight distances occur in design and in these locations can accommodate occasional multiple-vehicle passing.

Passing sight distance is an important criterion that is indicative of the quality of service provided by the road. In order to maintain the same level of service, passing sight distance should increase as road volumes increase. An initial road design would provide stopping sight distance over the full road length, with passing sight distance being checked afterwards. Insufficient passing sight distance may be corrected (e.g. by lengthening a vertical curve to provide PSD within the curve length or by shortening the curve to extend passing opportunities on either side of the curve). Horizontal curves may similarly be lengthened or shortened.

Standard minimum passing sight distances, for a range of design speeds and appropriate to South African conditions are shown in Table A.7. For safety and security reasons it is important to provide as many passing opportunities within each road section as possible. Long stretches of roadway where passing is prevented should be avoided at all times. The amount of passing sight distance available on a section of road has major impact on average traffic speeds, especially where the road is operating close to capacity.

Table A.7 : Passing sight distance on level roads	
Design speed (km/h)	PSD (m)
50	340
60	420
70	490
80	560

Source : UTG1 (1986)

#### 1.5.5 Shoulder sight distance (SSD)

At stop-controlled intersections the driver of a stationary vehicle should have sufficient visibility to allow him to cross the major road before an approaching vehicle reaches the intersection, even if this vehicle comes into view just as the stopped vehicle begins to cross.

The distance the crossing vehicle has to travel is the sum of the distance from the stop line to the edge of the through carriageway, the width of the road being crossed and the length of the crossing vehicle. This manoeuvre has to be completed in the time it takes for the approaching vehicle to reach the intersection, assuming that this vehicle is travelling at the design speed of that road. For safety, a time of two seconds should also be allowed for the driver to establish whether it is safe to cross, engage gear and move off.

For stop-controlled intersections, the line of sight is taken from a point on the centre line of the crossing road and 5 metres back from the edge of the through road to a point on the centre line of the through road (see Figure A.6).

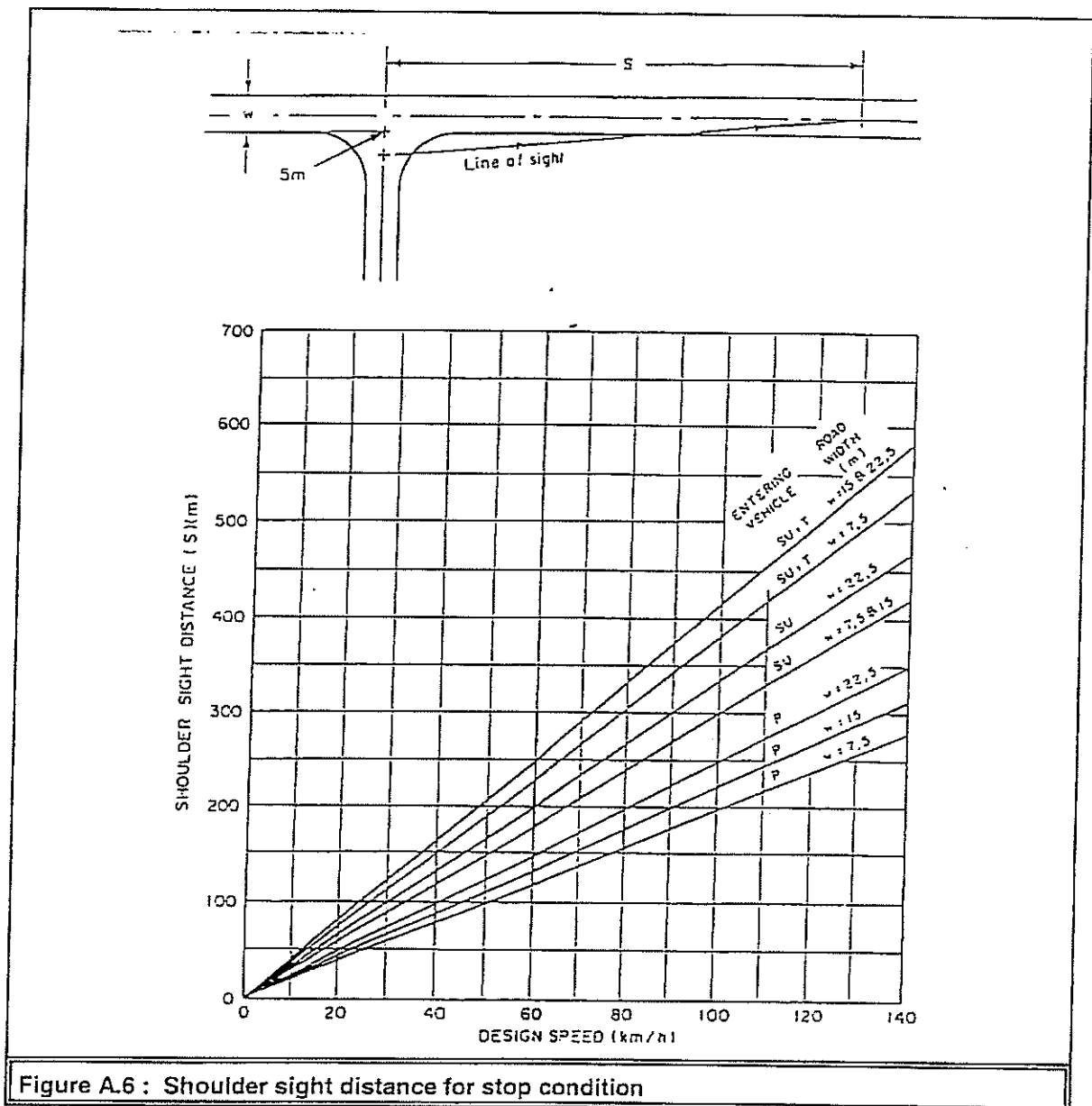

Figure A.6 : Shoulder sight distance for stop condition

The object height is taken as 1,3 metres and the driver eye height is 1,05 m for passenger cars and 1,8 m for all other design vehicles. Within the sight triangle (defined as the area enclosed by the sight line and the centre lines of the intersecting roads) there should be no obstruction to the driver's view.

Where intersections are yield-controlled, the unobstructed sight triangle should be enlarged. Assuming that the approaching driver is travelling at 60 km/h and preparing to stop, he would need 45 metres to do so. If he does not stop, but turns to travel in the same direction as a vehicle approaching at the design speed of the through road, the driver of the latter vehicle would be forced to slow down to match speeds at a safe following distance. The shoulder sight distance required for this is shown on Figure A.7.



Recommended shoulder sight distances are shown in Figure A.7. These should be adhered to and, in cases where values are reduced, the implications of departing from these recommended values should be studied.

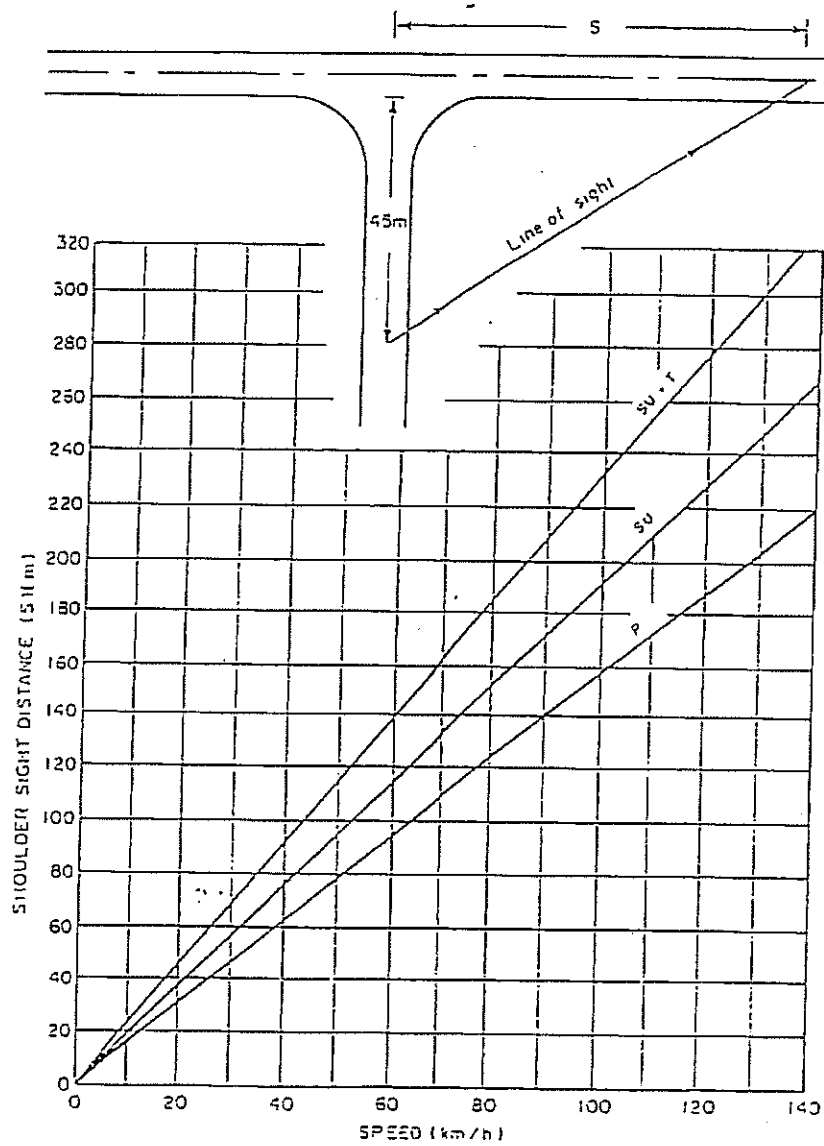

Figure A.7 : Shoulder sight distance for yield condition

### 1.6 Horizontal alignment

Horizontal alignment should be consistent with the standards outlined in UTG1 (1986). In addition the following design supplements should be followed:

- On lower order roads, the alignment should enhance both scenic views and discourage high speed traffic. The alignment should aim at minimising factors which may be aesthetically displeasing or which could introduce a nuisance value within neighbourhoods (e.g. excessive cuts and fills, sharp break-over angles, speed-inducing sections or cut throughs).
- Sharp horizontal curves should be avoided at or near the top of pronounced crest vertical curves and at or near the bottom of similar sag curves.
- The alignment should be consistent and not surprise drivers. Sharp curves immediately after long straight sections should be avoided.
- As a rule of thumb, the number of breaks in the course of a horizontal line that can be seen by a driver should not exceed two.
- Kerb alignments should always be smooth, and kinks (due to small deflection angles) should be avoided except at the beginning of a turning lane.
- Broken back curves should be avoided.

### 1.7 Vertical alignment

Vertical alignment is the combination of parabolic vertical curves and tangent sections of a particular slope. The selection of grade rates and lengths of vertical curves is based on assumptions about the driver, the vehicle and the roadway.

Vertical curvature, especially in combination with horizontal curvature, may limit sight distances. The slopes of tangent sections introduce forces that affect vehicle speed, driver comfort and the ability to accelerate and decelerate.

Again, it is important to design vertical alignment to be aesthetically pleasing. The inter-relationship between vertical and horizontal curvature should therefore be considered carefully. Where vertical curves coincide with horizontal curves, they should be contained within the horizontal curve and should preferably have lengths similar to those of the horizontal curves.

A smooth grade line with gradual changes appropriate to the road class and the character of the topography is preferred to an alignment with numerous short lengths of grade and vertical curves. The roller coaster or hidden dip type profile should be avoided. A broken back alignment is also not recommended (on aesthetic grounds) in sags where a full view of the profile is possible. On crests, the broken back alignment has an adverse effect on passing opportunities.

As long as the driver's line of sight is contained within the width of the roadway, the super-elevation generated by horizontal curvature improves the availability of sight distance, even

though the edge profiles may have a sharper curvature than that recommended. When the line of sight goes beyond the roadway edge, the effects of lateral obstructions (cut faces, vegetation etc.) on sight distances should be checked.

Passenger car speeds are relatively unaffected by grade. As truck speeds are seriously affected by grade, the designer should aim at providing grades that would not cause speed reductions of more than 20 km/h or there could be an increase in truck accidents and in the introduction of intolerable conditions for following drivers. Maximum grades of between 6 and 8 per cent on urban roads with design speeds of 50 to 80 km/h in flat terrain are recommended. In mountainous terrain these may be increased to between 9 and 11 per cent. In all cases the designer should ensure that, where speed reductions in excess of 20 km/h are likely to occur, auxiliary lanes are provided.

The critical length of grade is that length which causes the speed of the design truck to be reduced by 20 km/h. The starting point of the grade may be approximated as a point halfway between the preceding vertical point of intersection and the end of the vertical curve. The critical length therefore indicates where the provision of an auxiliary lane may need to be considered. The critical lengths of grades recommended are between 400 metres (for a 3 per cent gradient) and 150 metres (for an 8 per cent gradient). The recommended minimum gradient is 1 in 200 (0,5 per cent).

#### 1.8 Cross sectional elements

The basic components of the cross-section of the urban road that have to be accommodated within the road reserve are (Figure A.8):

- The roadway/s
- the verges
- the median (dual carriageway roads)

The roadway includes all cross-sectional elements between the kerb faces on either side. The factors affecting roadway width are the number of lanes and lane widths. The number of lanes is dependent on projected volumes.

The verge areas on either side of the roadway include all the elements from the kerb face to the property boundaries. The most significant factor affecting verge (and therefore reserve) width is the slope required for earthworks.

The median separates two carriageways and is measured from kerb face to kerb face. Median widths may be affected by the widths of right turning lanes, the width of the nose alongside the right turning lane and provision for future lanes. As medians are not relevant to this guideline, they will not be discussed further.

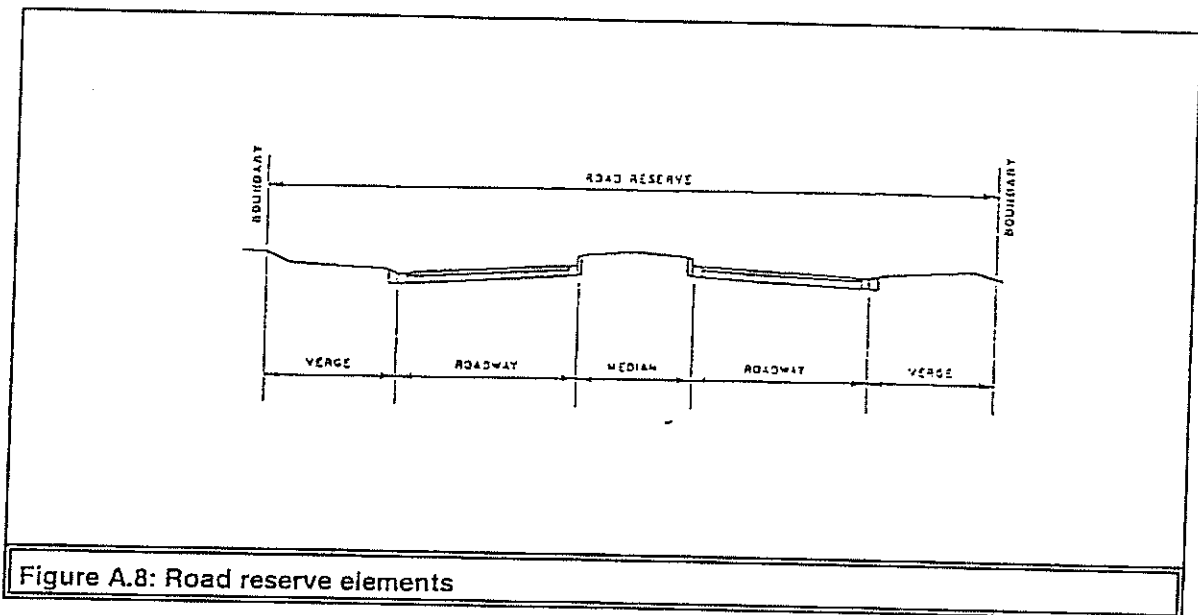

Figure A.8: Road reserve elements

### 1.8.1 Determining road reserve widths

Road reserve widths should be determined by providing for each of the cross-sectional elements. Arbitrary determination of road reserve width is not recommended since this may either be wasteful (using more land than is necessary) or lead to insufficient provision and difficulties through not taking sufficient load (especially where significant earthworks are needed).

Many authorities have policies regarding road reserve widths which prescribe nominal widths required for the various road classes.

### 1.8.2 Roadway elements

The roadway is defined as the area available for vehicle movement between the kerbs. In the case of class 5 roads (i.e. those applicable to traffic calming), the kerb separates the roadway from the verges on either side. The roadway width is measured from the bottom of the kerb face to the bottom of the opposite kerb face (see Figure A.9). Elements included in the roadway are:

- basic lanes;
- turning lanes;
- parking lanes;
- channels and offsets; and
- shoulders.

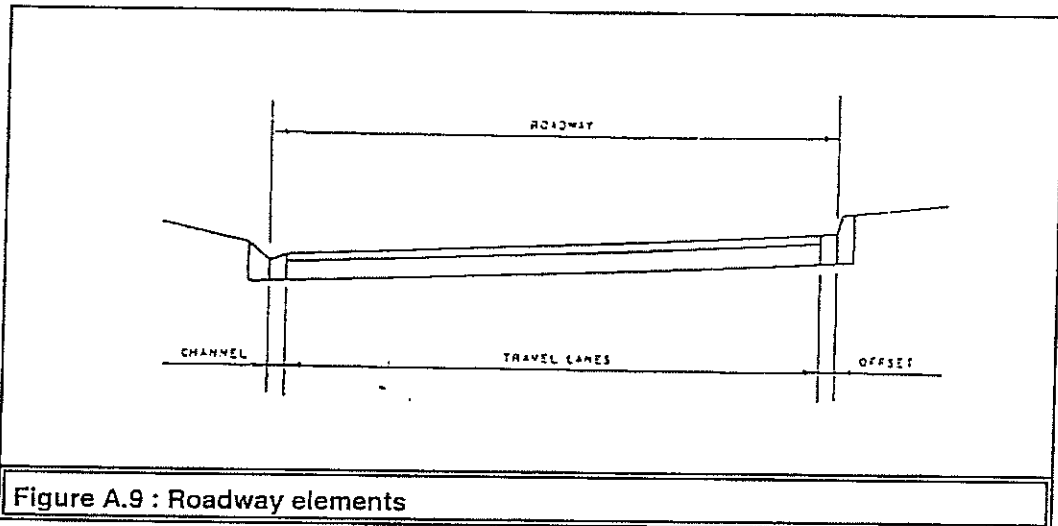

The provision of lanes should be based on the design hour volume of projected traffic in the design year (20 years from construction). If the design hour is a typical weekday peak hour, a Level of Service (LOS) D should be provided. The determination of capacity in relation to demand is described in more detail by Van As (1990) and in the Highway Capacity Manual (FHWA, 1985).

Lane widths should be sufficient to accommodate the width of the design vehicle, provide adequate clearance between vehicles and in the case of kerbside lanes, provide adequate clearance to kerbside objects. Ideally lanes should be 3,4 - 3,7 m in width (see Table A.8). Widths less than 3,4 m would still allow traffic operation although there would be an increase in driver tension and a greater risk of side-swipe accidents and collisions with fixed roadside objects. Lane widths below 3,0 m on higher order roads are not recommended (Schermers, 1994).

Lane width (m)	Vehicle types	Clearance (m)
3,0	car-car	1,2
	car-truck	0,8
	truck-truck	0,5
3,4	car-car	1,6
	car-truck	1,2
	truck-truck	0,9
3,7	car-car	1,9
	car-truck	1,5
	truck-truck	1,2

Source : UTG1

The recommended width for turning lanes is 3,0 m, measured from the centre of the lane line to the edge of the offset or channel. This may be increased to 3,4 m where there are high volumes of HGVs and/or buses. An absolute minimum width for turning lanes is 2,7 m, but only in TSM type improvements where otherwise a lane could not be provided.

Parking lanes may also be provided within the roadway. This may often be applicable in calming schemes where speeds need to be reduced through narrowing of the carriageway. In such instances embayment should be created within the roadway. The width of the parking lane would be the same as that of the through lanes. This is discussed in greater detail in later chapters. Reference should also be made to the Department of Transport's Parking Standards (SARB, 1985). The recommended width between the bottom of kerb faces and lane edge is 0,3 metres. The offset is provided by either a drainage channel, or where a channel is not needed, by a 0,3 m offset between the kerb and the edge of the lane.

### 1.8.3 Verge elements

The verge is measured from the bottom of the kerb face to the road reserve boundary (property line). Where no kerb exists, the edge of the roadway is used. The prime function of the road verge is to provide horizontal clearance to enhance the smooth and safe movement of vehicles in the roadway. It is also a buffer zone between the roadway and adjacent property and may therefore include landscaping, roadside furniture etc.

The recommended width of verge is 5,0 metres. This width can vary from road to road and may depend on the provision of verge elements. Also it is often impractical to set fixed verge widths other than a minimum width, ensuring that there is lateral clearance to the roadway and sight distance for safety. The absolute minimum is 2,0 metres which should be a clear strip with mountable kerbs. In areas where there is high pedestrian activity, the 2,0 m may be a sidewalk with barrier kerbs. Table A.9 gives the width requirements for certain verge elements. These serve as a guideline only and the provision of one feature would often satisfy the requirements of others (e.g. provision of a 5,0 m verge to accommodate vehicle access to private driveways would satisfy width requirements for most other elements).

Verge element	Width (m)
Mountable kerb	0,3
Semi-mountable kerb	0,15
Barrier kerb	0,15
Drainage, inlet, manhole	1,5
Clear verge (incl. Kerb and drainage inlet)	2,0
Sidewalk (footway)	1,5
Guardrails, barriers, walls	0,5
Electric light poles	0,3
Traffic signals	0,6 - 1,5
Traffic signs	0,6 - 2,0
Parallel parking	2,5
Driveway approaches	5,0
Trench width for underground services (minimum)	1,0
Bus stop embayment	3,0
Bus stop passenger queue	0,7 - 1,4
Bicycle paths	3,0
Landscape strip	3,0
Berm (1,5 m high)	6,0

Source : UTG1(1986)

### 1.9 Intersections

Intersection designs can be categorised into a limited number of basic forms (see Figure A.10), namely:

- T-type and T-skewed;
- Y-type;
- Cross and cross-skewed;
- Staggered (left and right) and staggered-skewed; and
- Multi-leg.

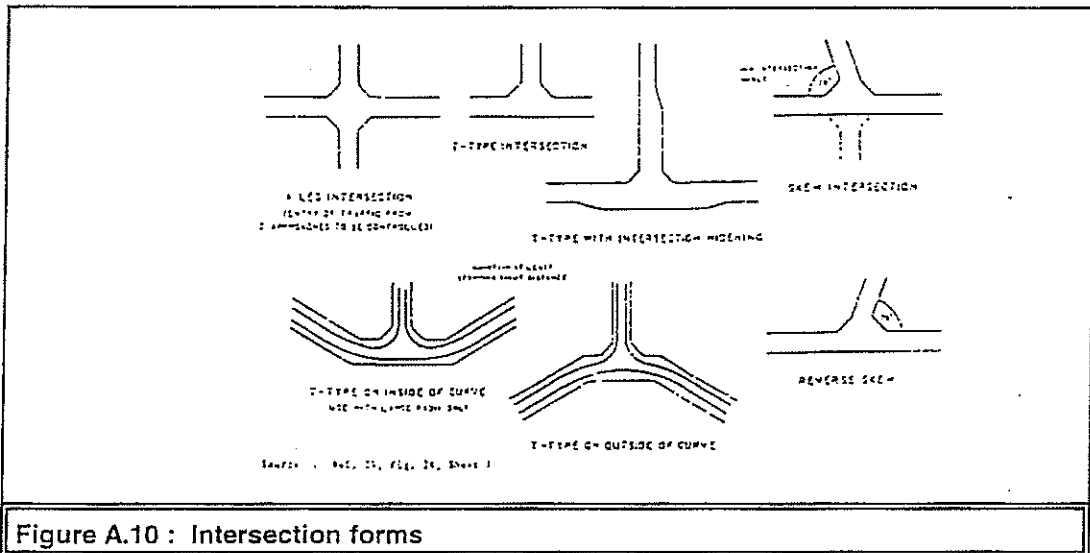

Figure A.10 : Intersection forms

In intersection design the following two rules apply:

- 1) No more than four two-way approaches (legs) should be planned for ; and
- 2) The angle of crossing manoeuvres should be as close to right angles as possible to accommodate the movements intended to operate at relatively high speeds.

The maximum departure from a right angle is recommended as 20°.

Staggered intersection layouts are acceptable, provided the distance between offset legs is sufficient for weaving and storage of right-turning traffic.

Intersections have a negative affect on traffic flow. Spacing is therefore important to minimise delays. However, on lower order roads spacing is affected more by the economic use of land than by providing for constant speed (Department of Community Development, 1983). On these roads intersections are used primarily to slow down speeds. Recommended intersection spacings are shown in Table A.10.

Spacing along road	Minimum intersection spacing (m)						
	Local Distributor	Residential access collector	Access loop	Access cull-de-sac	Access way	Access court	Access strip
Adjacent	80 - 90	60	40	-	40	-	-
Opposite	65 - 90	30	20	-	20	-	-

As access cul-de-sacs (Class 5c), access courts (Class 5e) and access strips (Class 5f) are closed systems, they will seldom have intersections along them. If however, access strips or courts are provided off an access cul-de-sac, the intersections should be spaced two erf frontages apart if they are adjacent or one erf frontage apart if they are opposite each other.



It is recommended that the designer also refers to the following geometric standards and guidelines relevant to urban roads:

- Guidelines for the provision of engineering services and amenities in residential township development, NHB, 1995.
- Guidelines for the provision of engineering services in residential townships, Department of Community Development, 1983.
- Guidelines on the planning and design of township roads and stormwater drainage, SAICE, 1981.
- Guidelines for the geometric design of urban arterial roads, CUTA, 1986.

#### 1.10 Road signs and signals

The designer should take the needs of the road user into consideration and should ensure that all measures are adequately signed. In all cases the SARTSM (1993) should be adhered to and all measures should be signed to ensure that:

- drivers have advance warning that they are about to enter a traffic calmed area;
- drivers have advance warning of the calming measure ahead;
- recommended speeds for the specific device are posted;
- signs indicating restricted access to certain vehicles be well posted on the surrounding road network;
- width and/or height restrictions be posted well in advance of such devices;
- schools and other high pedestrian activity environments be well signed to warn drivers that they are approaching an area where pedestrians have priority; and that
- drivers are warned that they are leaving the calmed area.

The use of traffic signals for intersection control within these areas is not recommended. Traffic signals should only be used at intersections of higher order roads and only if the use of signals is warranted (SARTSM). Flashing signals, warning drivers of a dangerous situation ahead, may be used.

APPENDIX B : OPINION SURVEY QUESTIONNAIRE (EXAMPLE)

# RIETONDALE - OPINION SURVEY TRAFFIC CALMING MEASURES

1 Your street name .....

2 Are you affected by the implementation of the new traffic calming measures?

1	YES	2	NO
---	-----	---	----

3 Indicate if any of the following occurred in your street due to the implementation of the new calming measures.

1	TRAFFIC VOLUMES DECREASED IN OUR STREET
2	TRAFFIC VOLUMES DECREASED IN OUR AREA
3	TRAFFIC SPEEDS DECREASED IN OUR STREET
4	TRAFFIC SPEEDS DECREASED IN OUR AREA
5	MY OWN DAILY TRAVEL TIME INCREASED
6	THE NEW CALMING MEASURES ENHANCE THE AESTHETICS OF OUR AREA
7	THE NEW CALMING MEASURES CAUSE FRUSTRATION FOR MOTORISTS
8	PEDESTRIAN SAFETY INCREASED IN OUR STREET
9	PEDESTRIAN SAFETY INCREASED IN OUR AREA
10	NOTHING CHANGED ACCORDING TO MY OPINION

Roads and  
Transport  
Technology

4 How would you describe the general traffic situation in the residential area, after implementation of the new calming measures.

1	BETTER	2	UNCHANGED	3	WORSE
---	--------	---	-----------	---	-------

CSIR

5 In general, are you satisfied with the calming measures implemented in your area?

1	YES	2	UNCERTAIN	3	NO
---	-----	---	-----------	---	----

6 Do you have any suggestions with reference to the new traffic calming measures?  
 .....  
 .....  
 .....

For any enquiries or further information regarding the installation of the traffic calming measures, please contact: Mr Kobus Labuschagne - City Engineer Pretoria City Council  
 Tel. 313-7648

PLEASE MAIL YOUR COMPLETED QUESTIONNAIRE IN THE BOXES PLACED AT RIETONDALE PRIMARY SCHOOL (KIESER AND NUFFIELD STREET GATES). BOXES WILL BE MARKED WITH THE CSIR LOGO. PLEASE RESPOND BEFORE 10 JANUARY 1996.



APPENDIX C(ii): ORIGIN-DESTINATION SURVEY FORM - ROADSIDE INTERVIEW

Origin - Destination Survey

Location :  
Approach :  
Conditions :

Date :  
Day :

\_\_\_\_\_

Time: \_\_\_\_\_

Vehicle type: \_\_\_\_\_

Origin of present journey: \_\_\_\_\_

Destination of present journey: \_\_\_\_\_

Purpose of trip: \_\_\_\_\_

Frequency of trip: \_\_\_\_\_

Number of passengers: \_\_\_\_\_

\_\_\_\_\_

Time: \_\_\_\_\_

Vehicle type: \_\_\_\_\_

Origin of present journey: \_\_\_\_\_

Destination of present journey: \_\_\_\_\_

Purpose of trip: \_\_\_\_\_

Frequency of trip: \_\_\_\_\_

Number of passengers: \_\_\_\_\_

\_\_\_\_\_

Time: \_\_\_\_\_

Vehicle type: \_\_\_\_\_

Origin of present journey: \_\_\_\_\_

Destination of present journey: \_\_\_\_\_

Purpose of trip: \_\_\_\_\_

Frequency of trip: \_\_\_\_\_

Number of passengers: \_\_\_\_\_

APPENDIX D: INTERSECTION COUNTS (EXAMPLE SHEET)

Intersection Counts

Location :

Date :

Approach :

Day :

Conditions :

Time :

Time (min intervals)	Turning Movement 1	Turning Movement 2	Turning Movement 3	Turning Movement 4
6:00				
15				
30				
45				
Hour Total				
15 min average				
7:00				
15				
30				
45				
Hour Total				
15 min average				
8:00				
15				
30				
45				
Hour Total				
15 min average				
9:00				
15				
30				
45				
Hour Total				
15 min average				

APPENDIX E : APPROPRIATE MEASURES FOR PEDESTRIANS AND  
HANDICAPPED PERSONS

1 Selection scheme for the provision of pedestrian crossing

Two fundamental concepts influence the decision whether or a specific crossing facility should be provided for pedestrians, namely sight distance/visibility and delay (acceptance of). The sight distance requirements of pedestrians are almost always greater than those of drivers. If sight distance is inadequate or delays (to cross) too long then the following provisions are possible (see Table E1):

Table E1: Provision matrix of sight distance

Provision	Sight distance inadequate	Delays to high
Remove obstacles	X	
Short crossing distance	X	X
Reduce vehicle intensity		X
Reduce vehicle speed	X	(X)
Influence gap distribution of traffic		X
Signalised pedestrian crossing	X	X
Change environmental characteristics.		X

Source : CROW (1990)

In a selection scheme for pedestrian crossings, the following characteristics should be common to all situations:

- crossing patterns, concentrated rather than distributed;
- presence of cyclists, on roadway or cycle path;
- traffic volume higher or lower than 400-600 vph; and.
- 85th percentile speeds higher or lower than 60 km/h.

These variables form the basis of the matrix shown on Figure E.1. The reference pages, giving possible solutions to specific situations, are presented in order of preference (i.e. a given situation where crossing is concentrated, cyclists use the roadway, volumes are less than 400-600 vph and 85th percentile speeds are below 60 km/h is preferred to a situation where crossing is distributed over length, a separate cycle path is provided, volumes are in excess of 400-600 vph and speeds in excess of 60 km/h).

The reference pages introduce two further characteristics, namely available width and the method of parking. Applicable measures are then identified for each situation and the specific page under which that/those measures can be found, referenced. In addition to these, the user should make extensive reference to the Department of Transport's pedestrian guidelines (SARB, 1987).

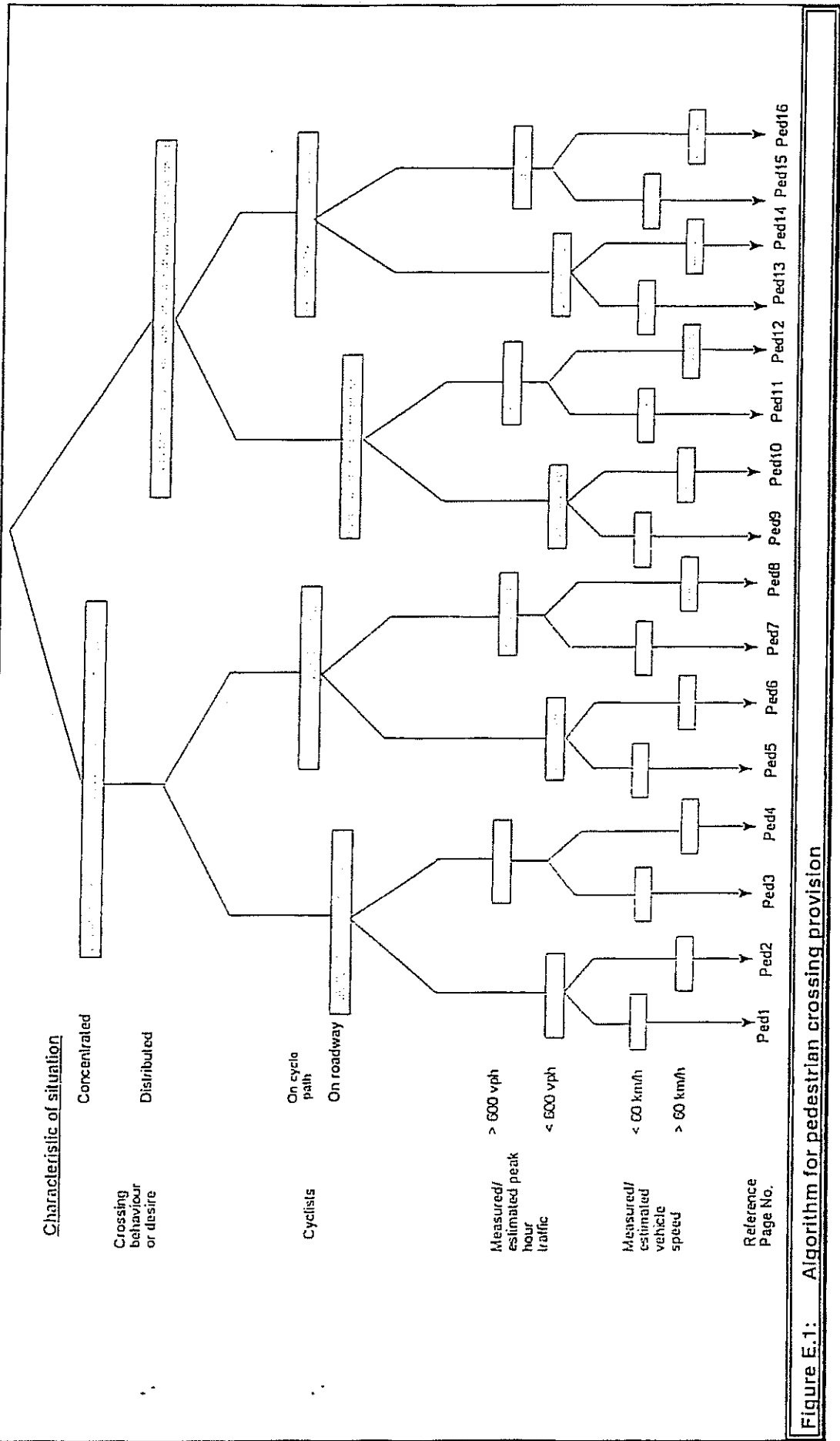

Figure E.1: Algorithm for pedestrian crossing provision

## REFERENCE PAGE Ped 1

## 1. Characteristics of the situation

- Concentrated crossing
- Cyclists on roadway
- Traffic volumes less than 400-600 vehicle-peak-hour
- 85th percentile approach speeds < 60 km/h

## 2. Considerations during measure selection

Crossing opportunity is improved by:

- shortening the crossing distance, narrowing to one travel lane is possible;
- the reduction of speed through vertical discontinuity or by adjustment of the horizontal length profile; and
- the introduction of medians and other intermediate support points.

Roads carrying little or no cycle traffic would be comparable to roads that have separate cycle facilities as described in Ped 5.

## 3. Provision of applicable measures

Parking method (Page no.)					
Road width	Chapter	Two sided	One sided	None	Not relevant
≤ 8,5 m	TM(Ch7)	64, 80	24, 42, 54, 58, 74, 80	33, 42	22, 40, 67, 69, 71, 75, 81
> 8,5 m	TM(Ch7)	41, 42, 46, 48, 69, 75, 80	24, 41, 42, 54, 55, 57, 58, 59, 69, 75, 80		22, 33, 40, 49, 50, 51, 67, 71, 81



## REFERENCE PAGE Ped 2

## 1. Characteristics of the situation

- concentrated crossing
- cyclists on roadway
- peak hour traffic volumes less than 400-600 vph
- 85th percentile > 60 km/h

## 2. Considerations during measure selection

Crossing opportunity may be improved by:

- reduction of speed through adjustment of horizontal profile/alignment;
- introduction of midway pedestrian islands; and
- reducing the crossing length, without necessarily having a major impact on higher approach speeds.

Should the objective be solely to provide a crossing point, then the reduction in speed, from a safety point of view, may not exceed 20 km/h. Should the objective be to reduce speed, then reference page Ped 1, may be used in combination with other measures, which should be introduced approximately 50 m to 70 m on either side of the recommended crossing measure.

## 3. Provision of applicable measures

Parking method (Page no.)					
Available road width	Chapter	Two sided	One-sided	None	Not relevant
≤ 8,5 m	TM(Ch7)		42*, 77	31*, 47, 86*, 88	71, 87*
> 8,5 m	TM(Ch7)	31, 42*, 80, 87*	42*, 77, 87*		47*, 49, 71, 87*, 88*

- \* Introduction measure to be used in conjunction with measure

## REFERENCE PAGE Ped 3

## 1. Characteristics of the situation

- concentrated crossing
- cycle traffic on roadway
- peak hour traffic volumes > 400-600 vph
- 85th percentile approach speed < 60 km/h

## 2. Considerations during measure selection

Crossing opportunity may be improved by:

- introduction of midway pedestrian islands;
- speed-reduction through adjustments in horizontal alignment; and
- reduction in crossing length. However, because of high volumes, both directions should be provided with a lane/s.

In situations where few or no cyclists make use of the roadway, then conditions are similar to a facility with a separate cycle path, as described in Reference Page Ped 7.

## 3. Provision of applicable measures

Parking method					
Available road width	Chapter	Two sided	One sided	None	Not relevant
≤ 8,5 m	TM(Ch7)	64, 80	42, 54, 64, 80	42, 47, 86	81
	CR (App. E)			E -52	
> 8,5 m	RU (App. E)				E - 38
	TM (Ch7)	31, 42, 48, 80	42, 54, 55, 80		47, 49, 50,51, 52, 81, 86
	CR (App. E)				E - 52

## REFERENCE PAGE Ped 4

## 1. Characteristics of the situation

- concentrated crossing
- cycle traffic on roadway
- peak hour traffic volumes > 400-600 vph
- 85th percentile approach speed > 60 km/h

## 2. Considerations during measure selection

Crossing opportunity may be improved by:

- introduction of midway pedestrian islands;
- reduction of speed through adjustment in horizontal alignment; and
- shortening the walking/crossing distance. Because of high speeds and volumes two travel directions must be accommodated.

This situation is similar to Ped 8 if there are few cyclists. Again, if the aim is to provide crossing opportunity, then speed may not be reduced by more than 20 km/h. Should speed-reduction be necessary, then measures described in Ped 3 may be applied in conjunction with other measures before and after the crossing.

## 3. Provision of applicable measures

Parking method (Page no.)					
Available road width	Chapter	Two sided	One-sided	None	Not relevant
≤ 8,5 m	TM (Ch7)		42*	42*, 47*, 86*, 88*	
> 8,5 m	RU (App. E)				E - 38
	TM (Ch7)	42*	42*		47*, 49*, 86*, 88*
	CR (App. E)				E - 52

- \* Applied as measures supplementary to the larger speed-reducing measures described in Ped 3

## REFERENCE PAGE Ped 5

## 1. Characteristics of the situation

- concentrated crossing
- cycle traffic on cycle path
- peak hour traffic volumes < 400-600 vph
- 85th percentile approach speed < 60 km/h

## 2. Considerations during measure selection

Crossing opportunity may be improved by:

- reduction of the crossing length, reduction to one-direction travel only is possible;
- reduction of speed through vertical discontinuity by adjustment to horizontal alignment;  
and
- introduction of midway pedestrian refuges.

## 3. Provision of applicable measures

Parking method (Page no.)					
Available road width	Chapter	Two sided	One sided	None	Not relevant
≤ 8,5 m	TM(Ch7)	64, 80	32, 40, 50, 64, 67, 68, 80	32, 40, 66, 67	21, 71, 75, 81
> 8,5 m	TM(Ch7)	21, 32, 40, 48, 66, 68, 75, 80	21, 32, 40, 54, 55, 63, 66, 68, 75, 80		49, 50, 51, 71

## REFERENCE PAGE Ped 6

## 1. Characteristics of the situation

- concentrated crossing
- cycle traffic on cycle path
- peak hour traffic volumes < 400-600 vph
- 85th percentile approach speed > 60 km/h

## 2. Considerations during measure selection

Crossing opportunity may be improved by:

- reduction in speed by altering horizontal alignment;
- introduction of pedestrian refuges; and
- reduction of crossing length, two-directional traffic should be accommodated.

Unless speed-reduction is an objective, traffic speeds may not be reduced by more than 20 km/h. If speed-reduction is the objective, the measures described in Ped 5 may be applied in conjunction with the supplementary measures shown below. These should be implemented 50-70 m before and after the selected measure.

## 3. Provision of applicable measures

Parking method					
Available road width	Chapter	Two sided	One-sided	None	Not relevant
≤ 8,5 m	TM(Ch7)		80	30, 47*, 70*, 86*, 88*	71, 87*
> 8,5 m	TM(Ch7)	66*, 87*,	80*, 87*		30, 47*, 49*, 71, 86*, 88*

\* Applied as supplementary measure (Ped 5)

## REFERENCE PAGE Ped 7

## 1. Characteristics of the situation

- concentrated crossing
- cycle traffic on cycle path
- peak hour traffic volumes > 400-600 vph
- 85th percentile approach speed < 60 km/h

## 2. Considerations during measure selection

Crossing opportunity may be improved by:

- provision of midway pedestrian refuges;
- reduction in speed through adjustment in horizontal alignment; and
- reduction in crossing distance, bi-directional traffic should be accommodated.

## 3. Provision of applicable measures

Parking method (Page no.)					
Available road width	Chapter	Two sided	One sided	None	Not relevant
≤ 8,5 m	TM(Ch7)	64, 80	41, 51, 67	30, 47, 86	81
	CR(App. E)			E -52	
> 8,5 m	TM(Ch7)	48, 80	54, 55, 80		30, 47, 49, 50, 51, 52, 81, 86
	CR(App. E)				E - 52

## REFERENCE PAGE Ped 8

## 1. Characteristics of the situation

- concentrated crossing
- cycle traffic on cycle path
- peak hour traffic volumes > 400-600 vph
- 85th percentile approach speed > 60 km/h

## 2. Considerations during measure selection

Crossing opportunity may be improved by:

- provision of midway pedestrian refuges;
- reduction in speed through change in horizontal alignment; and
- reduction in crossing distance, two-directional traffic should be accommodated.

Should speed-reduction be the objective apply measures as described in Ped 7. These should be supplemented by those shown below at a distance of 50-70 m on either side. Otherwise the selected measure should not cause speed to be reduced by more than 20 km/h.

## 3. Provision of applicable measures

Parking method (Page no.)					
Available road width	Chapter	Two-sided	One-sided	None	Not relevant
≤ 8,5 m	TM(Ch7)			30, 47*, 70*, 86*, 88*	
> 8,5 m	TM(Ch7)				30, 47*, 49*, 52, 86*, 88*
	CR(App. E)				E - 52

\* Applied as supplementary measure (Ped 7)

## REFERENCE PAGE Ped 9

## 1. Characteristics of the situation

- distributed crossing
- cyclists on roadway
- peak hour traffic volumes < 400-600 vph
- 85th percentile approach speed < 60 km/h

## 2. Considerations during measure selection

Crossing opportunity may be improved by:

- shortening the crossing distance, carriageway reduction to allow one-directional traffic possible;
- reduction in speed through vertical discontinuity and by changes in horizontal alignment; and
- introduction of midway pedestrian refuges.

With distributed crossings, provision may be made over the full length where crossing occurs or by multiple provisions along the length, spaced at a maximum of 70 m apart. In the last case, crossing between provisions is slightly improved as a result of nominal reduction in speed. If few cyclists use the road, reference can be made to the provisions on Reference Page Ped 13.

## 3. Provision of applicable measures

Parking method (Page no.)					
Available road width	Chapter	Two-sided	One-sided	None	Not relevant
≤ 8,5 m	TM(Ch7)	64	44, 54, 58, 64	33, 35, 36, 39, 44, 53	22, 23, 45, 67, 69, 75
> 8,5 m	TM(Ch7)	23, 41, 44, 46, 48, 69, 75	23, 24, 41, 44, 54, 55, 57, 58, 59, 69, 75		22, 33, 35, 36, 45, 51, 53, 67



## REFERENCE PAGE Ped 10

## 1. Characteristics of the situation

- distributed crossing
- cyclists on roadway
- peak hour traffic volumes < 400-600 vph
- 85th percentile approach speed > 60 km/h

## 2. Considerations during measure selection

Crossing opportunity may be improved by:

- reduction in speed by changing horizontal alignment;
- introduction of midway pedestrian refuges; and
- reduction in crossing length, two directional traffic to be accommodated.

Again two treatments are possible, namely over the full length or multiple provisions spaced 50-70 m apart.

If few cyclists use the road, the situation is similar to that in Reference Page Ped 14. If speed-reduction is required, Reference Page Ped 9 should be applied in conjunction with the supporting measures shown below. The supporting measures should be placed 50-70 m on either side of the crossing point.

## 3. Provision of applicable measures

Parking method					
Available road width	Chapter	Two-sided	One-sided	None	Not relevant
≤ 8,5 m	TM(Ch7)			36, 47*, 53, 86*, 88*	45, 47*
> 8,5 m	TM(Ch7)	87*	87*		36, 37, 44, 47*, 53, 86*, 88*

\* Applied as supplementary measure (Ped 9)

## REFERENCE PAGE Ped 11

## 1. Characteristics of the situation

- distributed crossing
- cyclists on roadway
- peak hour traffic volumes > 400-600 vph
- 85th percentile approach speed < 60 km/h

## 2. Considerations during measure selection

Crossing opportunity may be improved by:

- introduction of midway pedestrian refuges;
- reduction in speed through changes in horizontal alignment;
- reduction in crossing length. Because of high volumes two-directional traffic has to be accommodated.

The full road section may be treated, or multiple crossings, spaced 50-70 m apart, may be provided. If few cyclists use the facility, the situation is similar to that described in Reference Page Ped 15, which should then be used.

## 3. Provision of applicable measures

Parking method					
Available road width	Chapter	Two-sided	One-sided	None	Not relevant
≤ 8,5 m	TM(Ch7)	38, 64	38, 54, 64	38, 47, 53, 86	45
> 8,5 m	TM(Ch7)	38, 48	48, 54, 55		36, 37, 45, 47, 52, 53, 86

## REFERENCE PAGE Ped 12

## 1. Characteristics of the situation

- distributed crossing
- cyclists on roadway
- peak hour traffic volumes > 400-600 vph
- 85th percentile approach speed > 60 km/h

## 2. Considerations during measure selection

Crossing opportunity may be improved by:

- the introduction of midway pedestrian refuges;
- reduction of speed through changes in horizontal alignment;
- reduction in crossing distance. Because of high speeds bi-directional traffic volumes have to be accommodated.

If there are few cyclists, the measures applicable to Ped 16 can be adopted. If speeds require reduction, then the measures described in Ped 11 are applicable in conjunction with the measures indicated below. These complementary measures should be placed at a maximum distance of 50-70 m on either side of the crossing.

## 3. Provision of applicable measures

Parking method					
Available road width	Chapter	Two-sided	One-sided	None	Not relevant
≤ 8,5 m	TM(Ch7)			36, 47*, 53, 59*, 88*	45
> 8,5 m	TM(Ch7)				36, 37, 45, 47*, 53, 87*, 88*

\* Applied as supplementary measure (Ped 11)

## REFERENCE PAGE Ped 13

## 1. Characteristics of the situation

- distributed crossing
- cyclists on cycle path
- peak hour traffic volumes < 400-600 vph
- 85th percentile approach speed < 60 km/h

## 2. Considerations during measure selection

Crossing opportunity may be improved by:

- reduction of crossing distance, may reduce width to allow one-way traffic;
- reduction in speed by changing the horizontal alignment and introducing vertical discontinuity; and
- introduction of midway pedestrian refuges.

Two implementation options are possible, namely by treating the full length where crossing occurs or by providing crossing facilities every 50-70 m. In the latter case, opportunities to cross are improved on account of the lower speeds.

## 3. Provision of applicable measures

Parking method					
Available road width	Chapter	Two-sided	One-sided	None	Not relevant
≤ 8,5 m	TM(Ch7)	64	32, 34, 43, 53, 64, 66, 68	32, 34, 36, 39, 40, 43, 53, 66, 68	21, 23, 45, 75
> 8,5 m	TM(Ch7)	21, 23, 32, 34, 40, 43, 48, 66, 68, 76	21, 23, 32, 34, 40, 43, 54, 55, 57, 66, 68, 76		36, 45, 51, 53

## REFERENCE PAGE Ped 14

## 1. Characteristics of the situation

- distributed crossing
- cyclists on cycle path
- peak hour traffic volumes < 400-600 vph
- 85th percentile approach speed > 60 km/h

## 2. Considerations during measure selection

Crossing opportunity may be improved by:

- reduction in speeds through changes in horizontal alignment;
- introduction of midway pedestrian refuges; and
- reducing the crossing distance. Because of high speeds, two-way traffic should be accommodated.

Again the possibility exists of either implementing the measure over the full length where crossing occurs or of providing multiple points every 50-70 m. Should speed-reduction be needed, then the measures described in Ped 13 should be used in conjunction with the supplementary measures listed below, these being spaced 50-70 m on either side of the crossing.

## 3. Provision of applicable measures

Parking method					
Available road width	Chapter	Two-sided	One-sided	None	Not relevant
≤ 8,5 m	TM(Ch7)	38	38	36, 47*, 53, 86*, 88*	45, 87
> 8,5 m	TM(Ch7)	38, 87*	38, 87*		36, 45, 47*, 53, 86*, 88*

\* Applied as supplementary measure (Ped 13)

## REFERENCE PAGE Ped 15

**1. Characteristics of the situation**

- distributed crossing
- cyclists on cycle path
- peak hour traffic volumes > 400-600 vph
- 85th percentile approach speed < 60 km/h

**2. Considerations during measure selection**

Crossing opportunity may be improved by:

- introduction of midway pedestrian refuges;
- reduction in speed through vertical discontinuity or by changes in horizontal alignment; and
- reduction in the crossing distance; two-directional traffic should be accommodated.

The full length where crossing occurs may be treated or multiple provisions made every 50-70 m.

**3. Provision of applicable measures**

Parking method					
Available road width	Chapter	Two-sided	One-sided	None	Not relevant
≤ 8,5 m	TM(Ch7)	38, 64	38, 47, 64	36, 47, 53, 86	45
> 8,5 m	TM(Ch7)	38, 48	38, 54, 55		36, 45, 47, 51, 53, 86

## REFERENCE PAGE Ped 16

## 1. Characteristics of the situation

- distributed crossing
- cyclists on cycle path
- peak hour traffic volumes > 400-600 vph
- 85th percentile approach speed > 60 km/h

## 2. Considerations during measure selection

Crossing opportunity may be improved by:

- introduction of midway pedestrian refuges;
- reduction in speed through changes in horizontal alignment; and
- reduction in the crossing distance; two-directional traffic should be accommodated.

Either the full crossing length may be treated or multiple provisions made every 50-70 m. Should speed-reduction be required, the measures described on Reference Page Ped 15 should be used in conjunction with the supplementary measures shown below. These should be positioned at distances of not more than 50-70 m either side of the crossing provision.

## 3. Provision of applicable measures

Parking method					
Available road width	Chapter	Two-sided	One-sided	None	Not relevant
≤ 8,5 m	TM(Ch7)	38	38	36, 47*, 53, 86*, 88*	45
> 8,5 m	TM(Ch7)		38		36, 45, 47*, 53, 86*, 88*

\* Applied as supplementary measure (Ped 15)

## 2 Design principles for facilities for handicapped persons

In the design principles for the provision of facilities for handicapped persons distinction is made between:

- the environment;
- projection of routes; and
- design of the specific measures.

The living environment for a handicapped person is only usable if such persons can move around safely. The lay-out of this environment should also offer sufficient protection seeing that handicapped persons often experience discomfort from the inquisitive nature of people. At the same time social contact should be promoted because assistance is sometimes needed and more effort is required to become socially acceptable in the community. To meet the needs of disabled persons the following issues should be attended to:

### For blind or poorly sighted persons:

- avoid fixed obstacles as far as possible;
- avoid sudden changes in height;
- be aware that bicycles can hardly be heard on approach;
- benches and seats should be placed out of the travelled way;
- place guides around obstacles;
- as far as possible avoid placing loose objects (included parked cars) in the travelled walkway;
- provide as many uninterrupted guidance lines as possible;
- use contrasting colours and materials;
- provide large esplanades as recognisable walkways;
- design a clear framework structure (preferably a system that connects at right angles); and
- remember that a noisy environment would complicate acoustic orientation.

### For persons in wheelchairs:

- pay attention to the height of push buttons, parking metres and automated tellers and
- provide as much continuity in route character as possible (avoid long narrowed areas, stairs on wheel chair routes etc.)

### For people with walking disabilities:

- ensure convenient stairs with many landings; and
- place seats/benches conveniently and in sheltered places.

### For hard-of-hearing people:

- remember that approaching vehicles are hard to hear; and
- reduce the necessity to ask for directions by providing a framework structure and/or by providing information about this on a plan or map display.



Again, it is important that pedestrian routes make provision for handicapped persons. It is preferable to develop a structure plan, incorporating specific provisions for specific handicaps along routes within the structure plan. These specific provisions may be visually unique. The following principles would apply:

- The routes should be as safe and convenient as possible and should be accommodated, in order of priority, within the following cross-sectional elements:
  - pavements;
  - on cycle paths; and
  - on the roadway, only on those streets that have a predominantly residential function.
- As far as possible, routes should be able to serve both directions.
- On routes where persons with different handicaps have common O-D's, more facilities should be provided.
- The provision of facilities and/or measures is not dependent on the degree of utilisation. Facilities should still be provided, even if there are only small numbers of handicapped persons.

For the design of separate (individual) facilities the following principles apply:

- The provisions should be visible and logically planned. Complicated designs should be avoided.
- For the orientation of visually handicapped persons, as many "natural" measures (e.g. contrasting paving, edging etc.) as possible should be used.
- Provision should be made for audio signals at signalised pedestrian crossings.
- Ramps should be provided for wheelchairs on street corners and at pedestrian crossings. These should be every 100 m apart where a high degree of crossing occurs along the length of streets with a high pedestrian function.
- Pavements and sidewalks should be wide enough to allow free passage for wheelchairs.
- The accessibility of shops, public buildings and facilities (e.g. public telephones) merit special attention.
- Bus terminals, malls, rail stations and sometimes parking areas should provide marked walking lines for persons with poor sight.
- Where there is a lack in natural routing or where continual direction changes occur, tactile materials should be introduced. These materials should be unique to the pedestrian route and the colour specific to the environment.

- Consultation with interested and affected parties is necessary.
- Designs must also make provision for handicapped persons.

The system for the selection of provisions and measures for handicapped persons is shown in Figure E.2.

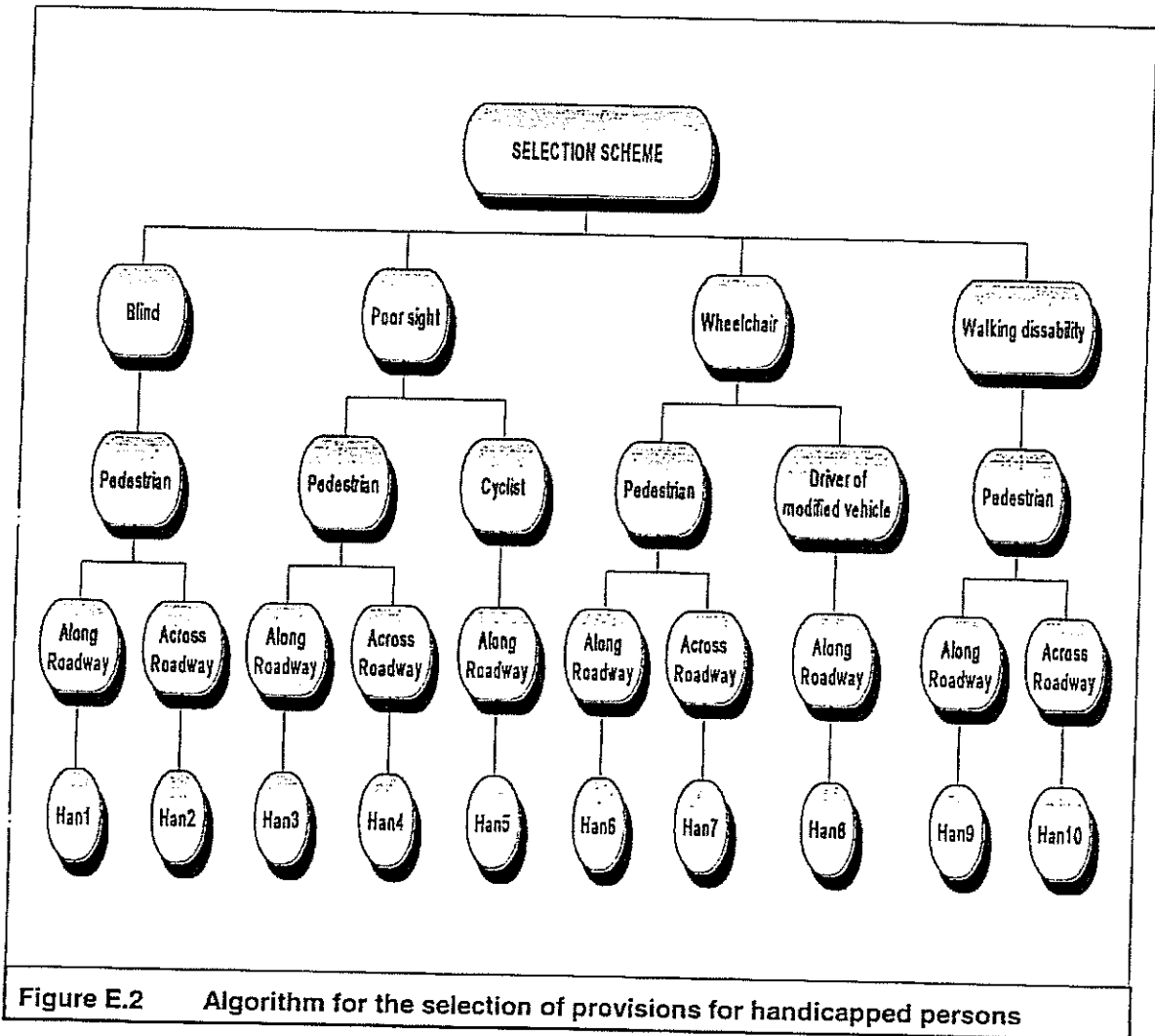

### 3 Selection system for provision for handicapped persons

The first consideration in the design of facilities for handicapped persons is the nature of the handicap. A distinction should therefore be made between the different ways in which the persons concerned participate in traffic. The routes that handicapped persons follow may both follow the street network and cross it. This is therefore also an important factor in the design process. In the selection of appropriate measures the following user characteristics are taken into account:

- The type of handicap;
- The method of participating in traffic; and
- The travel direction.

Some combinations are obviously not applicable while others do not require specific measures or provisions to be adopted. In principle, all the provisions discussed on the reference pages may be combined for a given traffic situation. However, the following are important:

- The continuity of measures along a route;
- The uniformity and consistency of measures, in relation to the usefulness and recognisability; and
- The combination of measures so that the positive effects of one measure cancel out the negative effects of another.

In conjunction with the above, the behaviour of other road users can be influenced by the introduction of speed-reducing measures or the creation of "Woonerf" areas. For persons with handicaps other than those listed in Figure E.2, the provisions made are listed in Table E.2.

**Table E.2 Provision for other handicaps**

Handicap	Provision	Chapter No and Reference Page
Deaf or hard of hearing	Obstacles - colour contrast	CR (E-50) SM (E-64, 66)
	Pedestrian crossing (among others the light intensity of signals)	CR (E-50)
Dwarfism	Railings and handles	RU (E-40,42,43)
	Height of push buttons	CR (E-50)
	Signing and marking	SM (E- 67, 68)
Hand and arm functioning	Railing and handles	RU (E-40, 42, 43)
	Push buttons	CR (E-50)

## REFERENCE PAGE Han 1:

## 1. User characteristic

Handicap	:	Blindness
Participation in traffic	:	Pedestrian with guide dog and/or stick (also as car passenger or user of public transport)
Travel direction	:	Along roadway

## 2. Consideration during selection of measures:

Depending on the situation, the following deserve attention:

Road surface	:	Type of surfacing, texture, transverse slope, level (flatness) and road roughness (unevenness)
Fixed obstacles (parking meters, stalls etc) and movable objects (bicycles, dustbins etc.)	:	Unobstructed (free) walking area (horizontal and vertical)

Applicable measures		Chapter and page no.
Road surface	general specific	SM (E-55) SM (E-57 - 58)
Vertical elements	stairs and balustrades	RU (E-40 - 43)
Obstacles	placement demarcation during construction	RU (E-45 - 47) SM (E-64 - 65) SM (E-69)
Street furniture	benches	RU (E-48)
Signing	placement and execution	SM (E-64)
Walk routes	guidance lines delineators	RU (E-44) SM (E-61, 63)

## REFERENCE PAGE Han 2:

## 1. User characteristic

Handicap	:	Blindness
Participation in traffic	:	As pedestrian with guide dog and/or stick (also as car passenger and public transport user)
Travel direction	:	Across the roadway

## 2. Consideration during selection of measures:

Depending on the situation, the following deserve attention:

Road surface	:	Type of surfacing, texture, transverse slope, level (flatness) and road roughness (unevenness)
Vertical elements	:	Construction of pavement ramps
Fixed obstacles (parking meters, stalls, etc) and movable objects (bicycles, dustbins etc.)	:	Unobstructed (free) walking area (horizontal and vertical)
Crossings	:	Signal with acoustic signal guidance lines, delineators, etc.

Applicable measures		Chapter and page no.
Road surface	general specific	SM (E-55 ) SM (E-57-58)
Vertical elements	crossings material	TM (Ch7, 85-87) SM (E-57)
Obstacles	placement	RU (E-47)
Protection at crossing	equipment composition/design	CR (E-50-51) SM (E-44-45)

## REFERENCE PAGE Han 3:

## 1. User characteristic

Handicap	:	Poorly sighted
Participation in traffic	:	Pedestrian (also passenger and public transport user)
Travel direction	:	Across the roadway

## 2. Consideration during selection of measures:

Depending the situation, the following deserve attention:

Road surface	:	Type of surfacing, texture, transverse slope, level (flatness) and road roughness (unevenness)
Fixed obstacles (parking meters, stalls etc) and movable objects (bicycles, dustbins etc.)	:	Unobstructed (free) walking area (horizontal and vertical)
Signing	:	Letter type, size and contrast

Applicable measures		Chapter and page no.
Road surface	general specific	SM (E-55) SM (E-57 - 58)
Vertical elements	stairs and balustrades	RU (E-40 - 43)
Obstacles	placement demarcation during construction	RU (E-45 - 47) SM (E-64 - 65) SM (E-69)
Furniture	benches	RU (E-48)
Signing	placement and execution	SM (E-67 - 68)
Walk routes	guidance lines delineators	RU (E-44) SM (E-61, 63)

## REFERENCE PAGE Han 4:

## 1. User characteristic

Handicap : Poorly sighted  
Participation in traffic : Cyclist  
Travel direction : Along the roadway

## 2. Consideration during selection of measures:

Depending on the situation, the following deserve attention:

Signing : Letter type, size and contrast

Applicable measures		Chapter and page no.
Signing	placement and execution	SM (E-49 - 50)

## REFERENCE PAGE Han 5:

## 1. User characteristic

Handicap	:	Poorly sighted
Participation in traffic	:	Pedestrian (also car passenger or public transport user)
Travel direction	:	Crossing the roadway

## 2. Consideration during selection of measures:

Depending on the situation, the following deserve attention:

Road surface	:	Type of surfacing, texture, transverse slope, level (flatness) and road roughness (unevenness)
Vertical elements	:	Construction of pavement ramps
Fixed obstacles (parking meters, stalls etc) and movable objects (bicycles, dustbins etc.)	:	Unobstructed (free) walking area (horizontal and vertical)
Crossings	:	Medians, guidance lines and delineators, pedestrian signals
Signing	:	Letter type, size and contrast

Applicable measures		Chapter and page no.
Road surface	general specific	SM (E-55) SM (E-57 - 59)
Vertical elements	crossings material	TM (Ch7, 58 - 87) SM (E-56)
Obstacles	placement	RU (E-45)
Protection at crossing	equipment composition/design	CR (E-50 - 51) SM (E-44 - 45)



## REFERENCE PAGE Han 6:

## 1. User characteristic

Handicap	:	Wheelchair users
Participation in traffic	:	In wheelchair (also as car passenger or public transport user)
Travel direction	:	Along the roadway

## 2. Consideration during selection of measures:

Depending on the situation, the following deserve attention:

Road surface	:	Type of surfacing, texture, transverse slope, level (flatness) and road roughness (unevenness)
Vertical elements	:	Incline, access criteria (in/out of vehicles etc)
Fixed obstacles (parking meters, stalls etc) and movable objects (bicycles, dustbins etc.)	:	Unobstructed (free) walking area (horizontal and vertical)
Signing	:	Letter type, size and contrast
Parking	:	See parking standards (Ref. SARB, 1985)

Applicable measures		Chapter and page no.
Road surface	general	SM (E-55)
Vertical elements	grades and guard rails	RU (E-38 - 40, 43)
Obstacles	placements during construction	RU (E-47) SM (E-69)
Street furniture	benches and tables	RU (E-48 - 49)
Signing	placement and execution	SM (E-49 - 50)

**REFERENCE PAGE Han 7:****1. User characteristic**

Handicap : Wheelchair users  
 Participation in traffic : As driver of vehicle  
 Travel direction : Along the roadway

**2. Consideration during selection of measures:**

Depending on the situation, the following deserve attention:

Parking : Parking bays with appropriate dimensions and pavement ramps (level)

Signing : Letter type and size

Applicable measures		Chapter and page no.
Parking	composition/design marking	RU (E-34-36) SM (E-68)
Signing	placement and execution warning and information	SM (E-67- 68) SM (E-66)

## REFERENCE PAGE Han 8:

## 1. User characteristic

Handicap	:	Wheelchair user
Participation in traffic	:	Wheelchair or invalid vehicle without motor (also as car passenger or public transport user)
Travel direction	:	Crossing the roadway

## 2. Consideration during selection of measures:

Depending on the situation, the following deserve attention:

Road surface	:	Type of surfacing, texture, transverse slope, level (flatness) and road roughness (unevenness)
Vertical elements	:	Pavement ramps, inclines access criteria (in/out vehicles)
Fixed obstacles (parking meters, stalls etc) and movable objects (bicycles, dustbins etc.)	:	Unobstructed (free) walking area (horizontal and vertical)
Crossings	:	Medians, guidance lines, delineators and pedestrian signals.
Signing	:	Letter type, size and height of signs

Applicable measures		Chapter and page no.
Road surface	general	SM (E-55)
Vertical elements	crossings material	TM (Ch7, 85 - 87) SM (E-68)
Obstacles	placement	RU (E-47)
Protection at crossings	equipment composition/design	CR (E-50-51 ) SM (E-63)
Signing	warning and information	SM (E-66)

## REFERENCE PAGE Han 9:

## 1. User characteristic

Handicap	:	Walking disability
Participation in traffic	:	As pedestrian (also as car passenger or public transport user)
Travel direction	:	Along the roadway

## 2. Consideration during selection of measures:

Depending on the situation, the following deserve attention:

Road surface	:	Type of surfacing, texture, transverse slope, level (flatness) and road roughness (unevenness)
Vertical elements	:	Stairs, access criteria (in/out vehicles etc.)
Fixed obstacles (parking meters, stalls etc) and movable objects (bicycles, dustbins etc.)	:	Unobstructed (free) walking area (horizontal and vertical)
Resting opportunities	:	Regular spacing between seating provision and opportunity.

Applicable measures		Chapter and page no.
Road surface	general	SM (E-55)
Vertical elements	stairs and balustrades crossings	RU (E-40 - 43) TM (Ch7, 87)
Obstacles	during construction	SM (E-69)
Resting opportunities	benches and tables	RU (E-68 - 69)

## REFERENCE PAGE Han 10:

## 1. User characteristic

- Handicap : Walking disability
- Participation in traffic : As pedestrian (also as car passenger and public transport user)
- Travel direction : Across the roadway

## 2. Consideration during selection of measures:

Depending on the situation, the following deserve attention:

- Road surface : Type of surfacing, texture, transverse slope, level (flatness) and road roughness (unevenness)
- Vertical elements : Pavement ramps, access criteria (in/out vehicles etc.)
- Fixed obstacles (parking meters, stalls etc) and movable objects (bicycles, dustbins etc.) : Unobstructed (free) walking area (horizontal and vertical)
- Crossings : Medians, delineators, extended pedestrian green times.
- Resting opportunities : Seating provision on medians.

Applicable measures		Chapter and page no.
Road surface	general	SM (E-55)
Vertical elements	crossings	TM (Ch 7, 87)
Protection at crossings	equipment	C (E-51)
Resting opportunities	benches	RU (E-48)

#### 4 Traffic provision for separate categories

This chapter contains details of measures specific to the following categories of road users:

- Motor vehicles, primarily passenger cars, although in some cases attention is given to taxis, HGVs and motor cycles.
- Public transport (buses), (this is covered in Chapters 6 and 7)
- Cyclists
- Pedestrians, also those who are handicapped.

The section on provision for motor vehicles in residential areas is supplementary to existing guidelines (Department of Community Development, SAICE) and focuses primarily on provision of parking for handicapped drivers. In most cases, calming measures are not specifically for one category of road user and therefore the section on provisions for mixed traffic (Chapter 6) deals in more detail with these. Facilities for the provision of services for public transport are covered by existing guidelines (DOT). Unique measures applicable to calming are dealt with in Chapter 6.

The measures described for cyclists essentially refer to separate cycle facilities, which include cycle paths and storage for bicycles. These are not dealt with detail since very few such facilities exist in South Africa.

The measures described for pedestrians relate primarily to pavements and separate pedestrian walkways. Generally the measures described are also applicable to the handicapped.

<u>DESCRIPTION</u>	<u>MEASURE PAGE</u>
Parallel parking for handicapped persons	RU1

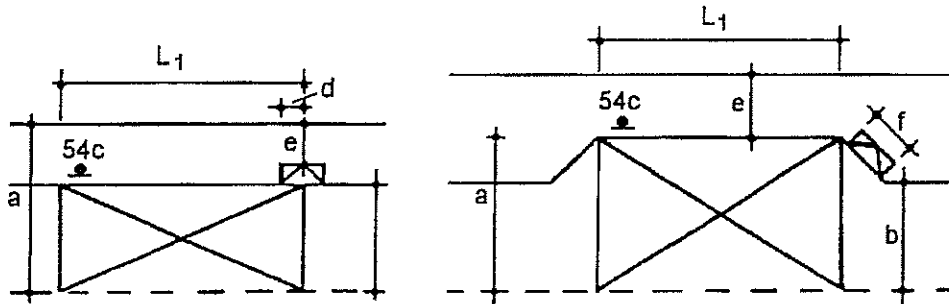
CONDITIONS FOR APPLICATION

- in parallel parking situations (on and off street)
- at least one bay situated  $\leq 50$  m from public buildings, destinations that are accessible to the handicapped and also residences for these people.
- the ratio of special to normal parallel parking bays should be 1:50 (or based on demand).

IMPLEMENTATION

- general parking for disabled persons sign (SARTSM)
- see SM8 for layout

POSITIVE ASPECTS

- promotes safe and independent participation (with other traffic) of handicapped persons

DIMENSIONS

- a = 3,5 m to accommodate additional space required to manoeuvre.
- $L_1 \geq 6,0$  m or 7,5 m where access is from the rear of the vehicle.
- b = 1,8 - 2 m
- d = 0,45 - 0,6 m
- e = 1,5 m
- f = 0,9 - 1,3 m

Height of parking meter head: maximum 1,1 m

ASSISTING MEASURES

See MT73 - 75

NEGATIVE ASPECTS

- additional land use
- utilisation often low
- parallel parking is often difficult for handicapped persons
- the taper into the pavement area causes discontinuity in the walkway and is expensive to construct

REMARKS:

Ref. Pages:  
Literature:

Han7  
SARTSM, CROW, Pedestrian Guidelines, Parking Standards

DESCRIPTIONMEASURE PAGE

Right angled parking for handicapped persons

RU2

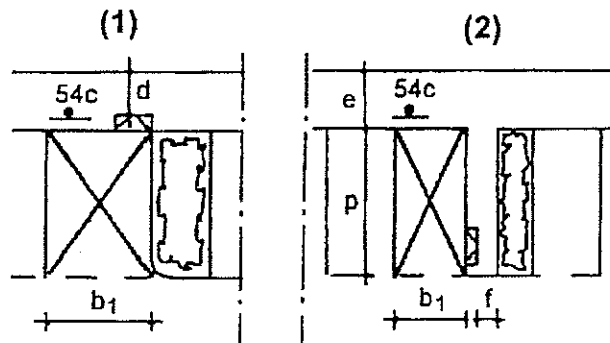
CONDITIONS FOR APPLICATION

- in right angled parking facilities
- at least one bay  $\leq 50$  m from public buildings, residences or facilities for handicapped persons.
- the ratio of special to normal bays 1:50 (or depending on demand).

DIMENSIONS

$p$	=	5,0 m
$b_1$	=	3,00 - 3,5 m (1)
	=	3,00 m (free disembarking area) (2)
$d$	$\geq$	1,5 m
$e$	=	0,9 - 1,2 m
$f$	$\geq$	1,2 m

Height of parking meter head: maximum 1,1 m

POSITIVE ASPECTS

- promotes safe and independent participation in traffic

NEGATIVE ASPECTS

- inefficient land use
- poor utilisation

REMARKS:

Ref. Pages: Han7  
Literature: DOT, SARTSM, Parking Standards, Pedestrian Guidelines

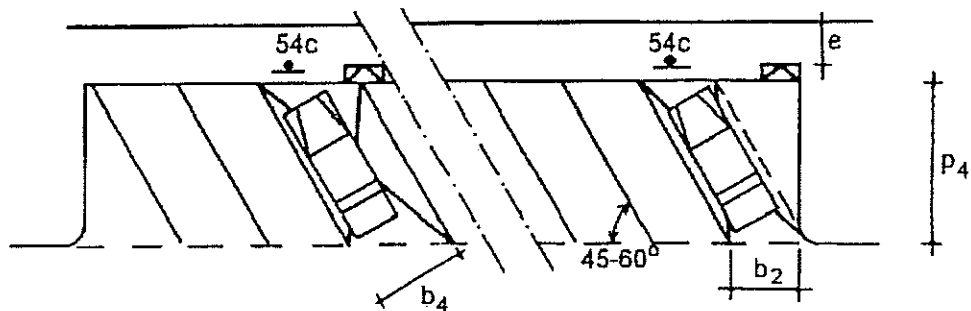

<u>DESCRIPTION</u>	<u>MEASURE PAGE</u>
Slanted (angled) parking for handicapped persons	RU3

CONDITIONS FOR APPLICATION

- at least one special bay  $\leq 50$  m from public buildings, residences of facilities for handicapped persons.
- the ratio of 1 special bay: 50 normal bays.

DIMENSIONS

- $b_2 = 2,25 - 2,5$  m
- $b_1 = 3,0 - 3,5$  m
- $e \geq 1,5$  m
- $p_4 = 4,8$  m ( $60^\circ$ );  $4,5$  m ( $45^\circ$ ) or  $4,0$  m ( $30^\circ$ )
- Height of parking meter head: maximum 1,1 m

IMPLEMENTATION

- signing (SARTSM)
- pavement/kerb detail see MT73 - 75 for layout refer to SM8
- use redundant space to offset poor utilisation
- generally possible to convert 3 existing bays to 2 special bays
- in parking garages place bays close to lifts, exits or at entrance to parking garage

ASSISTING MEASURESPOSITIVE ASPECTS

- promotes safe and independent participation in traffic

NEGATIVE ASPECTS

- poor utilisation
- inefficient land use

REMARKS:

Ref. Pages: Han7  
Literature: DOT, SARTSM, Parking Standards, Pedestrian Guidelines

DESCRIPTIONMEASURE PAGE

Separate cycle lane at intersection

RU4

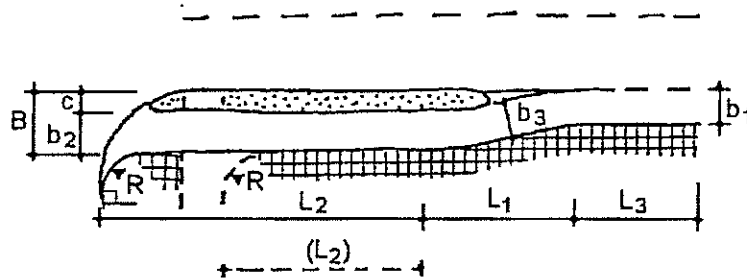
CONDITIONS FOR APPLICATION

- cycle paths next to crossing road
- in streets with a reasonable traffic function
- crossing provisions

DIMENSIONS

- $b_1 \geq 1,75 \text{ m (min 1,0 m)}$
- $b_2 \geq 2,5 \text{ m (min 1,75 m)}$
- $b_3 \geq b_2$
- $c \geq 1,0 \text{ m (crossing = 3,0 m)}$
- $l_1 = 10 \cdot c$
- $l_2 \geq 5,0 \text{ m}$
- $l_3 \geq 5,0 \text{ m}$
- $B \geq 3,5 \text{ m}$
- $R \geq 4,0 \text{ m}$

IMPLEMENTATION

Marking - see SM21 - 23  
 At signals - conflict free staging  
 One way traffic on cycle path

ASSISTING MEASURES

See MT87  
 Continuity in paving material and colour  
 Visual - vertical elements and signing

POSITIVE ASPECTS

- eliminates weaving
- allows staged crossing and reduces crossing length

NEGATIVE ASPECTS

- increase delay at signals
- storage length L2 too short then right turning and through cycles use roadway

REMARKS:

Ref. Pages: Ped 3,4  
 Literature: SARTSM, UTG1, Pedestrian Guidelines

DESCRIPTIONMEASURE PAGE

Variable and combined slopes

RU5

## SIDE VIEW

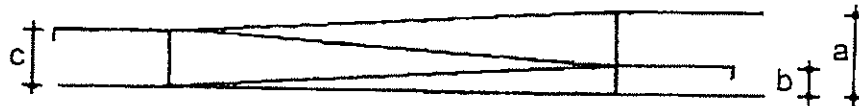

## PLAN

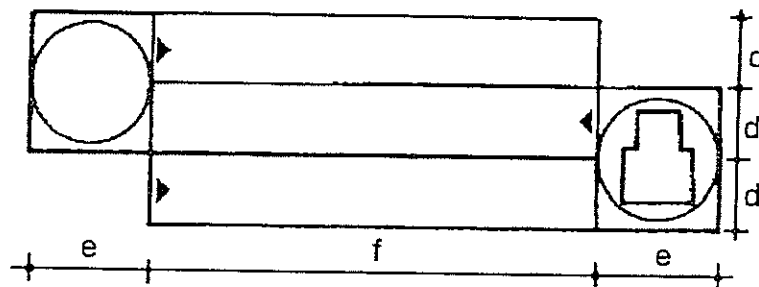
CONDITIONS FOR APPLICATION

- $a \leq 1,5$  m
- space restriction for the provision of continual slope

DIMENSIONS

$b \leq$	0,5 m
$c \leq$	1,0 m
$d =$	1,2 m
$e =$	1,5 m
$f =$	8 - 9 m

IMPLEMENTATION

- for the benefit of poorly sighted colour contrast at the beginning and end of slope
- railings
- ensure surface does not become slippery when wet

ASSISTING MEASURES

See RU6 - 8, RU10

POSITIVE ASPECTS

- minimal space requirement
- can be combined with stairs and railings
- promotes the shared use of facilities by handicapped persons

NEGATIVE ASPECTS

REMARKS: Ref. Pages: Han7  
Literature: UTG1, Pedestrian Guidelines, SARTSM

DESCRIPTIONMEASURE PAGE

Safety improvements on inclines and ramps

RU6

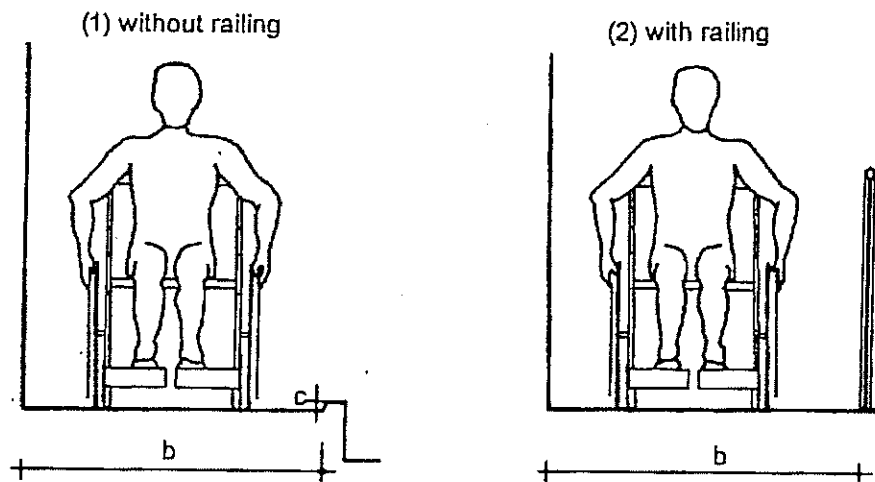
CONDITIONS FOR APPLICATION

- (1) height difference up to 0,25 m
- (2) height difference of 0,25 - 1,5 m

DIMENSIONS

- $b = 1,5 \text{ m}$
- $= 1,8 \text{ (with passing)}$
- $c \geq 0,04 - 0,1 \text{ m}$

IMPLEMENTATION

- if gradient is greater than 1:20, introduce stairs next to ramp
- level in horizontal plane
- stairs next to ramp improve choice for people with walking disabilities

ASSISTING MEASURES

See RU7, RU8, RU10

POSITIVE ASPECTS

- promotes safe and independent participation in traffic

NEGATIVE ASPECTS

- (2) expensive with long slopes

REMARKS:

Ref. Pages: Han6  
Literature: SARTSM, UTG1, Pedestrian Guidelines

DESCRIPTION

Railing along a slope

MEASURE PAGE

RU7

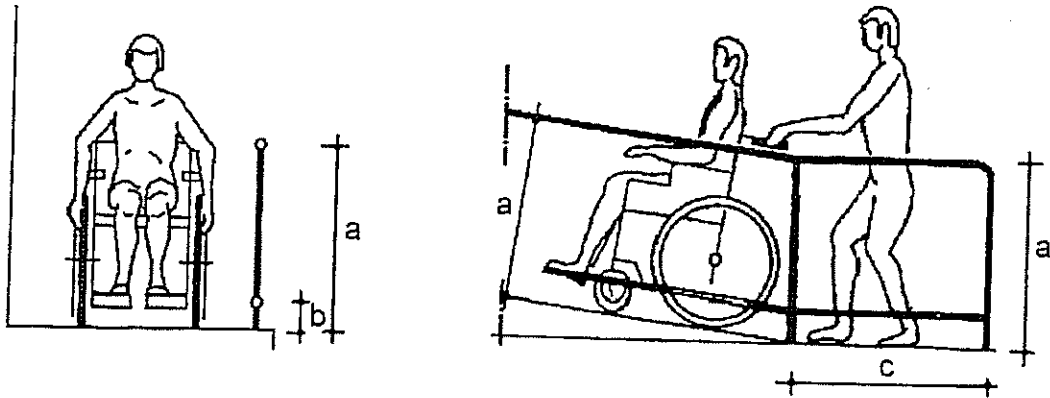
CONDITIONS FOR APPLICATION

- slope with height difference in excess of 0,25 m

DIMENSIONS

- a = 0,85 - 0,9 for people with walking disabilities
- 0,75 for wheelchair users
- 0,6 for small people and children
- 1,0 m on open side of stair flights
- b ≤ 1,0 m for visually handicapped with guide stick
- c ≥ 0,45 m at beginning and end of ramp

IMPLEMENTATION

- for wheelchair users introduce railing on both sides
- for visually handicapped introduce a white or yellow line (10 cm wide) across the full width at the beginning and end of the ramp
- See also RU10

ASSISTING MEASURES

See RU6

POSITIVE ASPECTS

- improved comfort for handicapped persons

NEGATIVE ASPECTSREMARKS:

Ref. Pages: Han 1,3,6,9  
Literature: UTG1, SARTSM, Pedestrian Guidelines

DESCRIPTIONMEASURE PAGE

Stairs

RU8

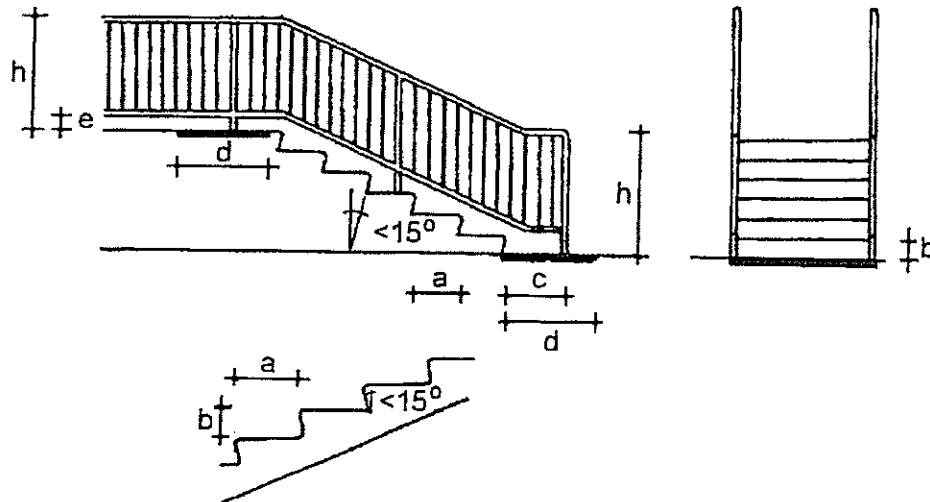
CONDITIONS FOR APPLICATION

- height differences  $\geq 0,25$  m

DIMENSIONS

- a = 0,33 - 0,34 m (stair)
- b = 0,14 - 0,15 m (riser)
- c  $\geq$  0,45 (landing)
- d = 0,6 (yellow rubber mat)
- e = 0,1 m
- h = 0,85 - 0,9 m
- = 1,0 (flights)

IMPLEMENTATION

- must be observable for visually handicapped
- warning marking on landings
- colour contrast between riser and stair
- stair lengths in excess of 3,0 m should be provided with a rest landing
- slip-free materials on stairs
- avoid sharp edges

ASSISTING MEASURES

See RU9, RU10

POSITIVE ASPECTS

- improves comfort/ease-of-use of handicapped persons

NEGATIVE ASPECTS

REMARKS: Ref. Pages: Han1, 3, 6, 9  
Literature: Pedestrian Guidelines, UTG1

<u>DESCRIPTION</u>	<u>MEASURE PAGE</u>
Railings along stairs	RU9

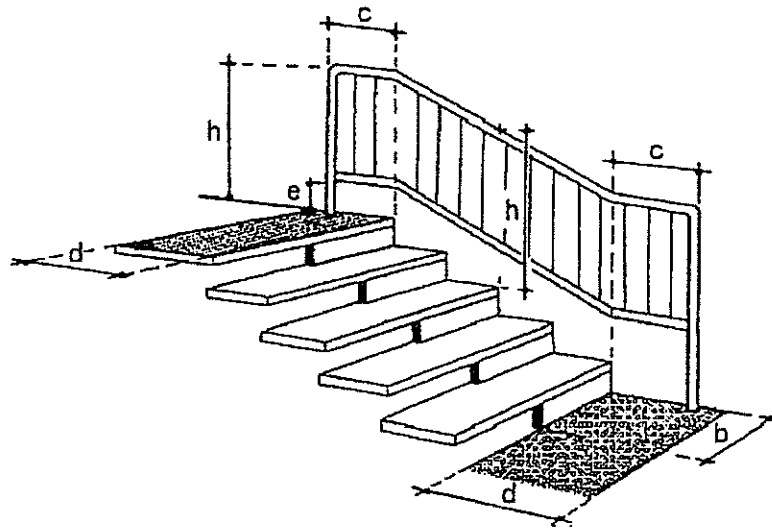
CONDITIONS FOR APPLICATION

- + next to stairs, for safety and walking comfort

DIMENSIONS

- $b \geq$  0,7 m (width of riser)
- $c \geq$  0,45 m
- $d =$  0,6 m (yellow rubber mat)
- $e \leq$  0,1 m
- $h =$  0,85 - 0,9 m  
or 1 m on open side of normal stairway

IMPLEMENTATION

- railing to be extended by at least 0,45 m on entry/exit to stairs and continued vertically to ground mounting. Ensure that the extension does not negatively affect other pedestrians
- ensure that the construction is such that falling off the stairs, or climbing over it, is not possible

ASSISTING MEASURES

See RU10

POSITIVE ASPECTS

- well designed and practical railings are important to both handicapped and other, especially elderly, users.

NEGATIVE ASPECTS

REMARKS: Ref. Pages: Han 1, 3, 6, 9  
Literature: Pedestrian Guidelines, UTG1

DESCRIPTIONMEASURE PAGE

Railing detail

RU10

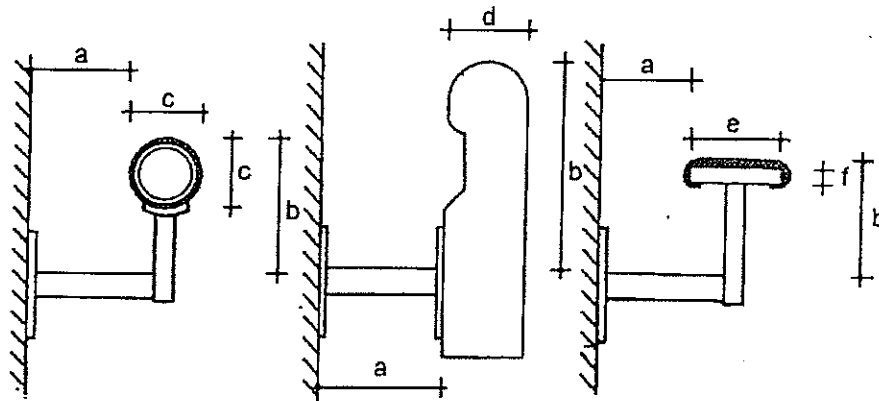
CONDITIONS FOR APPLICATION

- along stairs and ramps
- (1) for people who use the railing to pull themselves along
- (2)(3) in walking areas/passages where the railings are used to guide people

DIMENSIONS

a =	4 - 6 cm
b ≥	6 cm
c =	4,1 cm
d =	4 - 4,5 cm
e =	5 cm
f =	8 mm

IMPLEMENTATION

- optimum grip is given by providing a round form
- (1) round tubular profile
- (2) wood
- (3) steel strip
- railings should not end abruptly
- railing in contrasting colour
- the handrail should be of such a size that the whole hand can enclose it
- resistant to side forces
- (1)(3) provide padding that contrasts with the surroundings

ASSISTING MEASURESPOSITIVE ASPECTS

- ease/comfort for elderly and handicapped.

NEGATIVE ASPECTS

REMARKS: Ref. Pages: Han1, 3, 6, 9  
Literature: Pedestrian guidelines



DESCRIPTIONMEASURE PAGE

Guidance or reference lines for handicapped persons

RU11

Guidance lines are a series of elements which help visually handicapped persons orientate themselves. These include small walls, kerbing, fences or changes in pavement texture and colour.

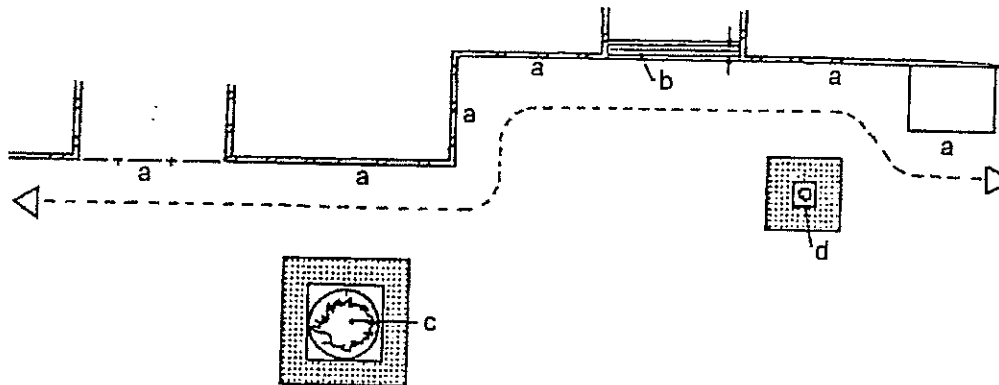
CONDITIONS FOR APPLICATIONDIMENSIONS

- walking routes for handicapped persons.
- a = reference line (facade, gate, grass edge)
- b = guiding line (where there are breaks in the reference line)
- c = flower pots with paving/tiles around them
- d = show cases with paving/tiles around them

IMPLEMENTATIONASSISTING MEASURES

- traditional kerbing cannot be relied on for reference nor can it be raised above pavement level
- reference lines should be easily detectable (grass edging, plants, picket fencing)
- existing reference line should be used for orientation
- breaks in the existing/natural reference line should be avoided
- where long breaks occur, introduce contrasting materials to warn vulnerable pedestrians

See SM11, SM14, SM15, RU12, RU13

POSITIVE ASPECTSNEGATIVE ASPECTS

- promotes safe and independent participation
- also assists other road users
- making use of natural/existing reference lines is cheaper than constructing supplementary one

- temporary facilities (hawker stalls etc) have a negative influence
- recessed facades cause unnatural breaks in orientation and complicate the provision of continuity

REMARKS:

Ref. Pages: Han1, 3  
Literature: Pedestrian Guidelines

DESCRIPTIONMEASURE PAGE

Placement of obstacles

RU12

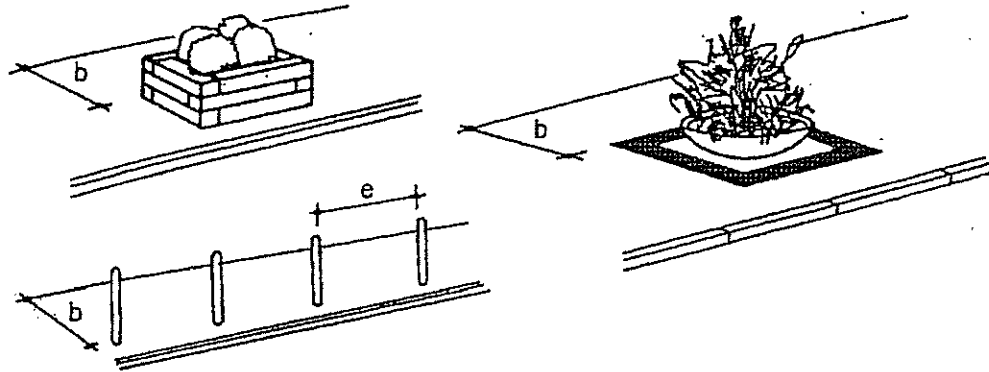
CONDITIONS FOR APPLICATIONDIMENSIONS

- on footways and in pedestrian areas, specifically with respect to visually handicapped

b = 0,9 - 1,2 m  
e = 1,2 m

IMPLEMENTATIONASSISTING MEASURES

- keep away from walking areas/route
- mount signs on facades
- place obstacles in a straight line along the walk route
- where  $0,9 < b < 1,2$  no special provision for blind persons, other than marking (see SM14)
- where  $b \leq 0,9$ , special provision for blind persons

See SM13, SM14, RU13

POSITIVE ASPECTSNEGATIVE ASPECTS

- promotes safe and independent participation in traffic

REMARKS:

Ref. Pages: Han 13, 5  
Literature: Pedestrian Guidelines

DESCRIPTIONMEASURE PAGE

Layout dimensions for obstacles

RU13

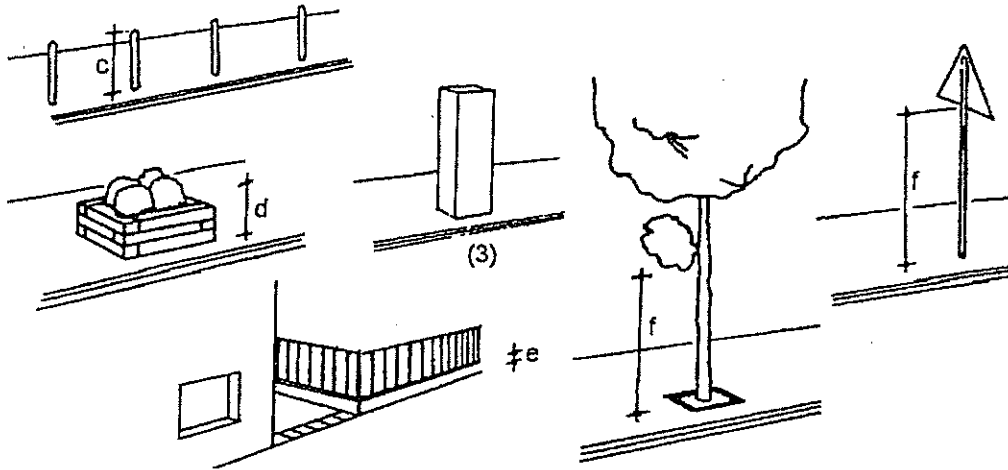
CONDITIONS FOR APPLICATION

- on footpaths or in pedestrian areas, with particular emphasis on visually handicapped persons

DIMENSIONS

- $c = 0,6 - 0,75$  m
- $e = 0,1 - 0,15$  m (raised edge)
- $f \geq 2,2$  m
- $d \leq 0,6$  m (including dense planting; to prevent children from hiding)

Fences, hedges and walls maximum of 0,6 m high

IMPLEMENTATION

- obstacles should be visible and not obstruct disabled persons
- height should be such that they are readily detectable
- prune overhanging greenery
- no protruding part on poles etc.

ASSISTING MEASURES

See RU12, SM14, SM12, RU11

POSITIVE ASPECTS

- promotes safe and independent participation in traffic

NEGATIVE ASPECTS

REMARKS: Ref. Pages: Han1, 3, 5  
Literature: Pedestrian Guidelines

DESCRIPTIONMEASURE PAGE

Partial closure of cycle/pedestrian paths

RU14

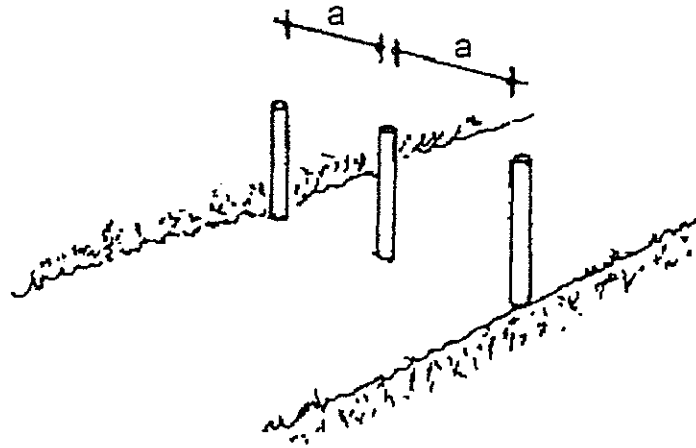
CONDITIONS FOR APPLICATION

- prevention of unwanted motorised traffic

DIMENSIONS

a = 1,2 m

IMPLEMENTATION

- in a colour that contrasts with the surroundings
- ensure that wheel chair users are not excluded
- collapsible so that wider emergency vehicles need to use the facility

ASSISTING MEASURES

See RU12, SM13, SM14

POSITIVE ASPECTS

- promote safe and independent participation in traffic

NEGATIVE ASPECTS

- passing width of 1,2 m may be abused by motorcyclists
- dangerous for cyclists

REMARKS:

Ref. Pages:

Han 1, 2, 3, 6, 8

Literature:

Pedestrian Guidelines

DESCRIPTIONMEASURE PAGE

Resting facilities - benches

RU15

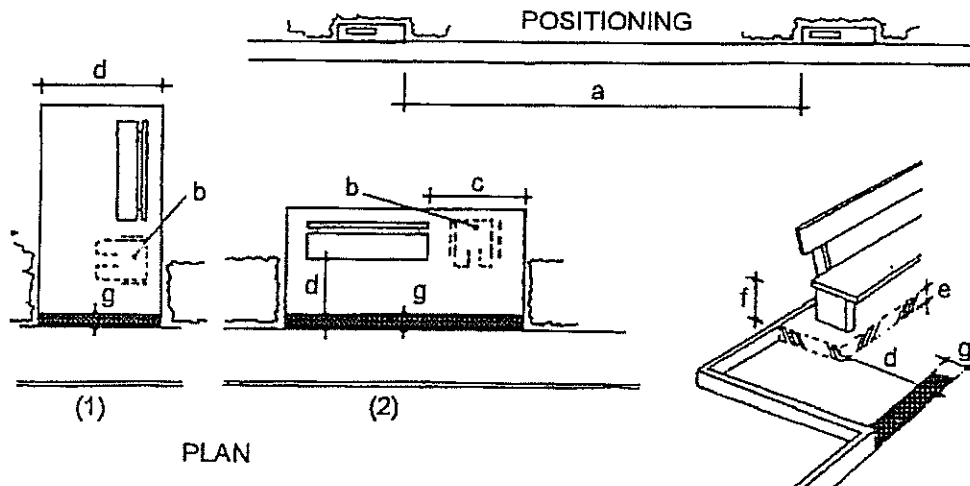
CONDITIONS FOR APPLICATION

- along shopping streets
- public transport facilities
- on pedestrian walkways
- in parks etc.

DIMENSIONS

a =	100 m (shopping centres) 200 m (other areas)
c ≥	1,2 m
d ≥	1,2 m
e =	1,5 m
f =	8 - 9 m
g =	0,3 m (warning markings)

IMPLEMENTATION

- for the benefit of poorly sighted: colour contrast at the beginning and end of slope
- railings
- ensure surface does not become slippery when wet

ASSISTING MEASURES

See RU6 - 8, RU10

POSITIVE ASPECTS

- minimal space requirement
- can be combined with stairs and railings
- promotes the shared use of facilities by handicapped persons

NEGATIVE ASPECTS

REMARKS: Ref. Pages: Han 1, 3, 6, 9  
Literature: Pedestrian Guidelines

DESCRIPTIONMEASURE PAGE

Resting opportunities: Seating with table

RU16

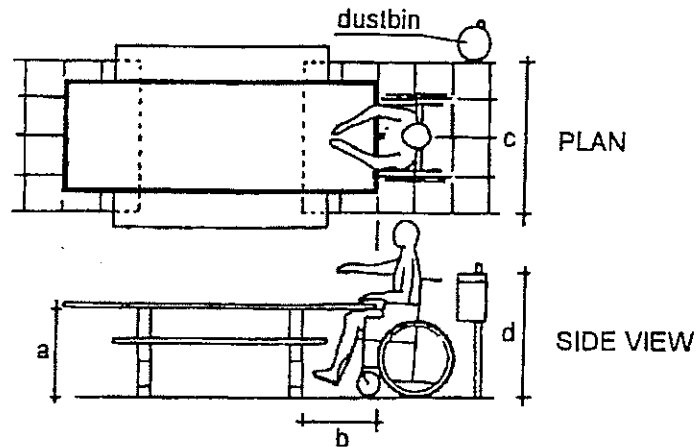
CONDITIONS FOR APPLICATION

- in residential areas, parks, walking trails

DIMENSIONS

a ≥	0,7 m
b ≥	0,6 m
c ≥	1,2 m
d =	1,0 m

IMPLEMENTATION

- table height such that wheelchair can fit underneath
- ensure easy access to toilets, telephones, dustbins etc.
- dustbins in contrasting colours (for poorly sighted)
- table and dustbins accessible on paved surface

ASSISTING MEASURES

See RU15, SM14

POSITIVE ASPECTS

- improves utilisation of recreational facilities
- promotes safe and independent participation in traffic

NEGATIVE ASPECTS

REMARKS: Ref. Pages: Han 6, 9  
Literature: Pedestrian Guidelines

#### 4.1 Measures aimed at regulating orderly movement

This section contains information relating to possible supplementary traffic signalisation and pedestrian control techniques. The designer should make use of existing guidelines for pedestrian provision (DOT), signalisation (SARTSM and Van As) and road signing and marking (SARTSM).

<u>DESCRIPTION</u>	<u>MEASURE PAGE</u>
Regular crossings for pedestrians	CR1

---

---

<u>CONDITIONS FOR APPLICATION</u>	<u>DIMENSIONS</u>
<ul style="list-style-type: none"> <li>• concentrated crossings</li> <li>• volumes <math>\geq 1000</math> pcu/peak hour (2 lane roads) <math>\geq 2000</math> pcu/peak hour (4 lane roads) regular pedestrian demand</li> <li>• 85th percentile speed <math>&lt; 50</math> km/h</li> <li>• distance to intersection <math>\geq 40</math> m</li> </ul>	<ul style="list-style-type: none"> <li>• pedestrian call button 1,25 m</li> <li>• pedestrian heads, located by taking account of poor sighted users.</li> </ul>

<u>IMPLEMENTATION</u>	<u>ASSISTING MEASURES/ POSSIBLE COMBINATIONS</u>
<ul style="list-style-type: none"> <li>• pedestrian green phase set on walk speed of 1,2 m/s or between 0,5 and 1 m/s for handicapped persons</li> <li>• high concentrations of handicapped persons replace call button with pressure plates (clearly marked) and guidance lines to them</li> <li>• warning signs and markings (SARTSM)</li> <li>• light intensity (SABS)</li> </ul>	Guidance lines: see SM12 and SM16

<u>POSITIVE ASPECTS</u>	<u>NEGATIVE ASPECTS</u>
<ul style="list-style-type: none"> <li>- relatively safe</li> </ul>	<ul style="list-style-type: none"> <li>- red light violations</li> <li>- approaches to crossing relatively unsafe</li> </ul>

<u>REMARKS:</u>	Ref. Pages:
	Table E.2, Han2, 5, 8, Ped 3, 4, 7, 8
	Literature: SABS 1547: 1992; Pedestrian guidelines; SARTSM

DESCRIPTIONMEASURE PAGE

Audio Aid at Signals (Pedestrian)

CR2

CONDITIONS FOR APPLICATION

- Where visually handicapped persons cross

DIMENSIONSIMPLEMENTATION

- a device in or at signalised controlled crossing which transmits an audio signal to blind or poorly sighted persons in order to tell them when to cross
- clear distinction between signals when allowed to and not allowed to cross
- clearly audible without being disruptive to other residents
- prevent using too many such signals close to one another
- braille instructions on panel of push button
- audio signal available on request

ASSISTING MEASURES/  
POSSIBLE COMBINATIONS

- Regular crossing: see Pedestrian Guidelines
- Guidance lines: see SM12 and SM16

POSITIVE ASPECTS

- clearly understood by visually handicapped
- improves localised crossing
- improves children's crossing behaviour

NEGATIVE ASPECTS

- Disturbing to other residents (especially at night) if not implemented as recommended

REMARKS:

Ref. Pages: Han 2, 5, 8, 10  
Literature: SABS 1547: 1992; Pedestrian Guidelines; SARTSM



## 4.2 Measures in support of the calming effect

DESCRIPTION

Uneven paving on part of road/road section

MEASURE PAGE

SM1

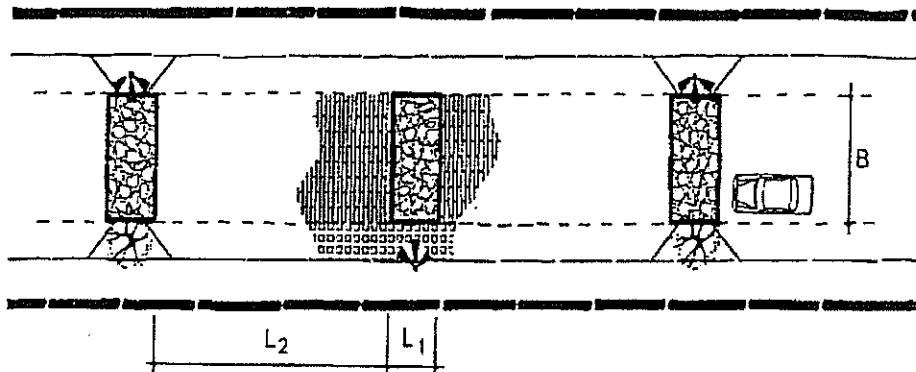
CONDITIONS FOR APPLICATION

- $B < 6$  m
- peak hour traffic 400 - 600 vph
- 85th percentile speeds  $< 60$  km/h
- not on main roads
- not on cycle route

DIMENSIONS

- $L_1 = 3 - 6$  m
- $L_2 = 20 - 30$  m
- paving raised to 2 - 5 cm

IMPLEMENTATION

- vehicles should be able to pass obstructions at an acceptable speed
- material: roughly finished concrete paving, tiles, clinkers, natural stone or cobbles on the necessary foundations
- place on protrusions, if present
- use over whole width of roadway
- ensure recognisability by the use of contrasting materials, vertical elements, sufficient illumination

ASSISTING MEASURES/  
POSSIBLE COMBINATIONS

- physical assistance/support: see TM23, TM25, TM31, TM39
- visual assistance/support

POSITIVE ASPECTS

- moderate to good speed-reduction, depending on material used
- does not affect parking space supply
- can be used on provisioning routes

NEGATIVE ASPECTS

- inconvenient to cyclists where there are no cycle lanes
- increase in noise pollution and vibrations
- dissimilar/unequal friction coefficient

REMARKS:

Ref. Pages: SR3, 4  
Literature: DOT Pedestrian Guidelines; Parking Standards; UTG1; SARTSM

DESCRIPTION

Paving of sidewalk and roadway on the same level

MEASURE PAGE

SM2

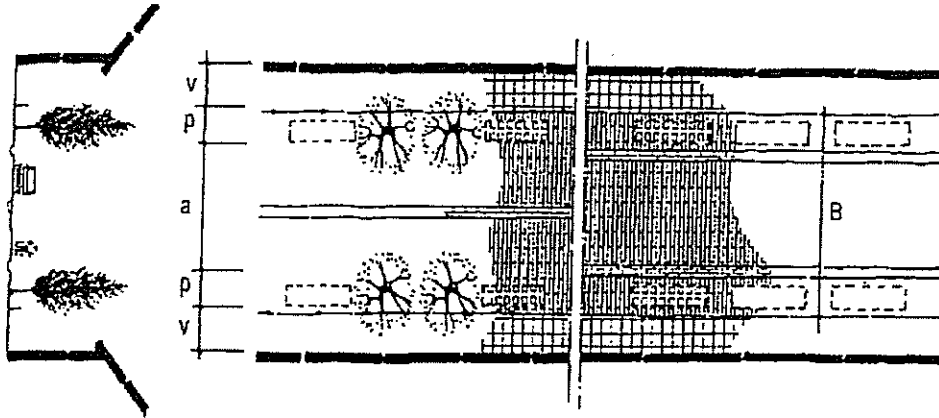
CONDITIONS FOR APPLICATION

- $B < 6 (7) \text{ m}$
- peak hour volumes  $< 400 - 600 \text{ vph}$
- not on main road
- where parking is not required

DIMENSIONS

- $a = 4.5 - 5 \text{ m}$  with two-way traffic
- $= 5 - 6$  with bus and/or truck traffic
- $= 3.25 - 3.5 \text{ m}$  with limited restricted one-way traffic
- $p = 1.8 - 2 \text{ m}$  (increase with heavy cycle traffic)
- $v = 1.5 - 2 \text{ m}$  in residential street
- $= 2 - 4 \text{ m}$  in shopping street

IMPLEMENTATION

- pedestrian area should be clearly recognizable (it should be impossible to mistake it for a "woonerf")
- provide loading zones in shopping streets
- drainage by 1 or 2 gutters

ASSISTING MEASURES/  
POSSIBLE COMBINATIONS

- no-parking signs (obligatory in urban areas)

POSITIVE ASPECTS

- partial integration of different road users
- moderate to good speed-reduction
- can be used on cycle, bus and/or provisioning supply routes

NEGATIVE ASPECTS

- parking on pedestrian area
- cyclists on the sidewalk can be annoying and dangerous
- gutters are inconvenient to cyclists and the less mobile

REMARKS:Ref. Pages:  
Literature:

SR3,4

DOT Pedestrian Guidelines; Parking Standards; UTG1; SARTSM

DESCRIPTIONMEASURE PAGE

Corners with raised rumble strips

SM3

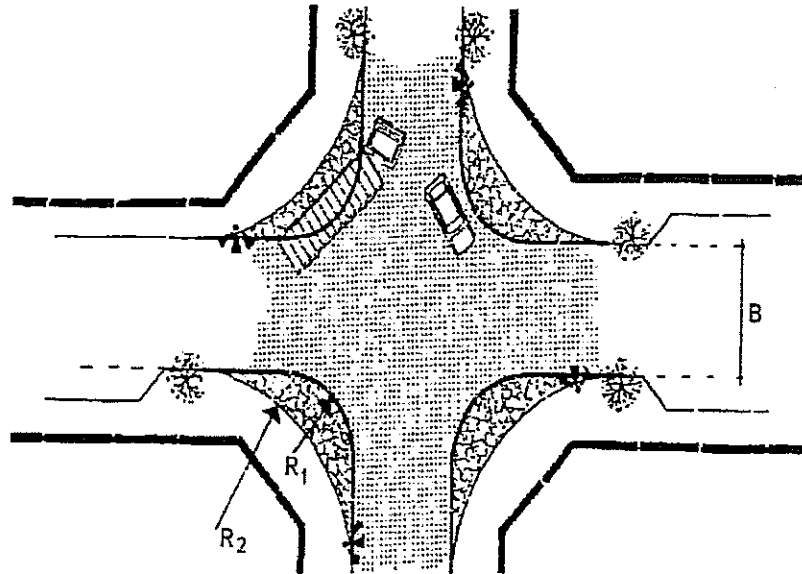
CONDITIONS FOR APPLICATION

- $B < 6$  (7) m
- peak hour volumes  $< 400 - 600$  vph
- not on main road
- on corners with trucks turning right or left [not on a bus route, except where buses do not turn off  $R_1 > 15$  m]

DIMENSIONS

- $R_1 = 3 - 7.5$  m
- $R_2 = 7.5 - 15$  m, depending on width of roadway and manoeuvrability of vehicles planned for

IMPLEMENTATION

- vehicles should be able to pass obstruction at an acceptable speed
- material to be used: uneven concrete tiles, clinkers, natural stone or cobbles on a foundation
- should be made clearly recognizable by choice of material, vertical elements and provide adequate lighting

ASSISTING MEASURES/  
POSSIBLE COMBINATIONS

- physical assistance/support: see TM73
- visual assistance/support

POSITIVE ASPECTS

- left-turning traffic is slowed down
- can be used on cycle and/or provisioning supply routes

NEGATIVE ASPECTS

- very inconvenient for right-turning cyclists (except where there is a cycle road/way)
- inconvenient for pedestrians crossing especially the disabled and aged
- dissimilar/unequal friction coefficient
- no speed-reduction for ongoing traffic
- illegal parking

REMARKS:Ref. Pages:  
Literature

SR1, 2, 3, 4

DOT Pedestrian Guidelines; Parking Standards; UTG1; SARTSM

DESCRIPTIONMEASURE PAGE

Paving of sidewalks and pedestrian routes

SM4

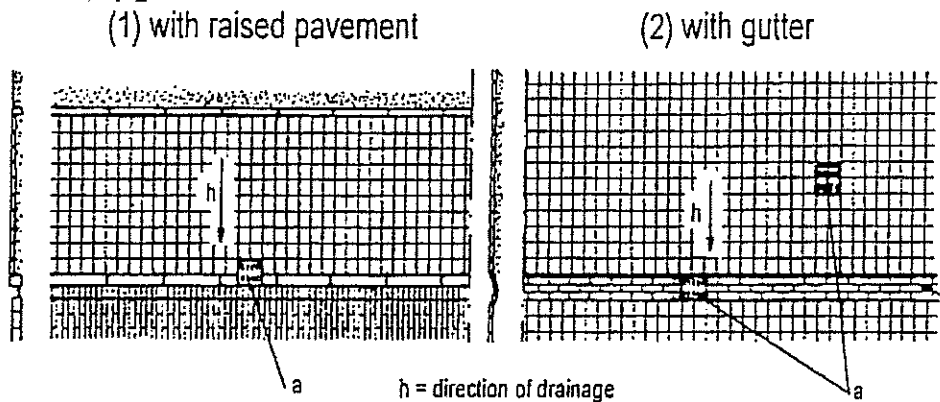
CONDITIONS FOR APPLICATION

- sidewalks and pedestrian ways

DIMENSIONS

- a = road or sidewalk drain
- b = gutter
- h = 1:100 (1:50)

IMPLEMENTATION

- paving: levels, closely fitting and non-skid
- gutters: no sudden differences in levels, incorporate smoothly into sidewalk and roadway, should be replaced by alternative drainage system if possible
- drains and gratings should be placed outside walkway
- drain coverings: mesh size 0.02 x 0.02 m or diameter 0.02m; manhole cover with recessed grips parallel to direction of movement, or cover with grating

ASSISTING MEASURES/  
POSSIBLE COMBINATIONS

- drainage
- guidance line: see SM10

POSITIVE ASPECTS

- slight slope in direction of movement prevents discomfort and the resultant movement to the roadway by persons in wheelchairs
- promotes safe and independent participation in traffic by the disabled
- beneficial to the elderly, pedestrians with poor mobility and those using crutches

NEGATIVE ASPECTS

- possible poor drainage on wide paved areas, which may result in puddles. Where this happens, more drains should be incorporated in the sidewalk and road

REMARKS:

Ref. Pages: Han 1, 2, 3, 5, 6, 8, 9, 10  
 Literature: DOT Pedestrian Guidelines; Parking Standards; UTG1; SARTSM

DESCRIPTION

Kerb-cut ramp

MEASURE PAGE

SM5

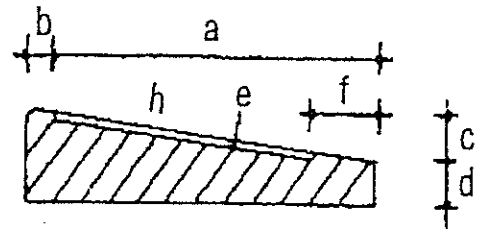
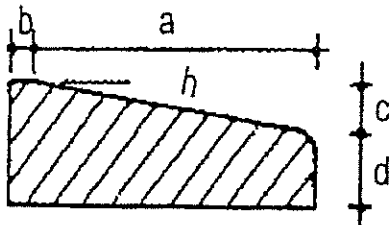
CONDITIONS FOR APPLICATION

- difference in level  $\leq 10$  cm (if  $> 10$  cm: see TM58)
- (1) width of sidewalk  $> 2.15$  m (including kerb)
- (2) width of sidewalk  $\geq 2.30$  m (including kerb)
- transverse gradient of roadway  $\leq 1:50$

DIMENSIONS

- $h =$  circa 1:6 (1)  
= circa 1:8 (2)
- $a =$  60 cm (1)  
= 74 cm (2)
- $b =$  5 cm (1)  
= 6 cm (2)
- $f =$  15 cm
- $c =$  10 cm (1)  
= 9 cm (2)
- $d =$  8 cm (1)  
= 3 cm (2)
- length = 50 cm

IMPLEMENTATION

- use prefabricated parts (side and centre parts)
- (1) is easier to use by letting the kerb and sidewalk slope slightly backwards (where the sidewalk is narrow)

ASSISTING MEASURES

- parking areas: see RU1 - 3
- pedestrian crossings: see TM58 - 60
- (2) may be used in combination with an inlaid rubber mat (e) as warning system
- flower-beds on both sides of (2) (to a height of 60 cm) improve orientation possibilities for the visually impaired

POSITIVE ASPECTS

- not necessary to lower the kerb

NEGATIVE ASPECTS

- cannot be used without reservation (too steep)
- where poorly constructed, wheelchairs can get stuck or fall over
- rubber carpets (if used) can create orientation problems for the visually impaired
- not easily manageable

REMARKS:

Ref. Pages:  
Literature:

Han 2, 5  
DOT Pedestrian Guidelines; Parking Standards; UTG1; SARTSM

DESCRIPTIONMEASURE PAGE

Guidance tile

SM6

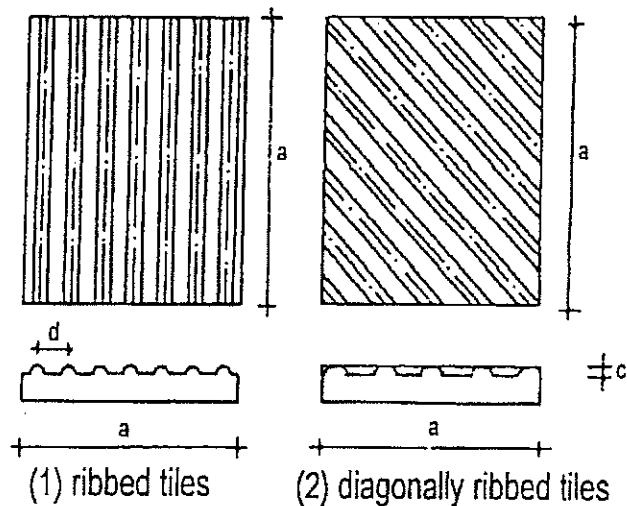
CONDITIONS FOR APPLICATION

- in guiding lines to help the visually impaired, on sidewalks and hiking routes where there are no natural guiding signs
- in guiding lines leading to pedestrian crossings use (1)

DIMENSIONS

- $a = 30$  cm
- $c \leq 0,5$  cm (above paving level)
- $d = 4 - 5$  cm

IMPLEMENTATION

- for placing of guidance lines see SM10, SM11
- lowest level of ribbed tile should be level with the adjacent paving
- use a lighter colour than the adjacent paving, for instance a light grey, brown, white or yellow

ASSISTING MEASURESPOSITIVE ASPECTS

- clearly distinguished/defined signal and tactile information for the visually impaired

NEGATIVE ASPECTSREMARKS:

Ref. Pages:  
Literature:

Han1, 2, 3, 5  
DOT Pedestrian Guidelines; Parking Standards; UTG1; SARTSM

DESCRIPTION

Warning tiles

MEASURE PAGE

SM7

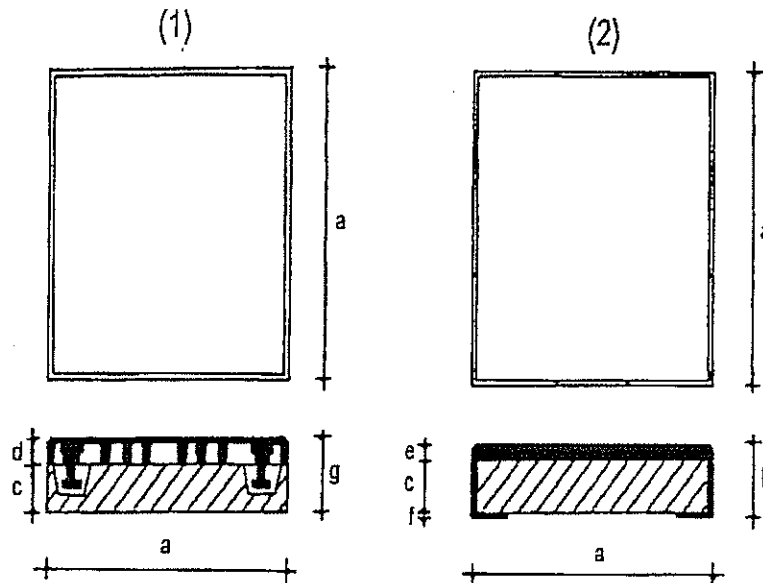
CONDITIONS FOR APPLICATION

- + [around obstacles which are difficult to detect by the visually impaired]
- + (2) on junction/intersection of guiding lines in pavement
- + [(2) at pedestrian crossings]

DIMENSIONS

- a = 0.30 m
- c = 5 cm
- d = 3 cm
- e = 1.5 cm
- f = 0.05 cm
- g = 8 cm
- h = 7 cm

IMPLEMENTATION

- concrete covered by rubber
- for location see SM12
- for guidance lines at pedestrian crossings see SM11
- for obstacles see RU12, RU13
- preferably not on rounded corner kerbs as the joints may give problems
- use a darker colour, e.g. black

ASSISTING MEASURESPOSITIVE ASPECTS

- rubber tiles have a different sound from that of the adjoining pavement. In this way the visually impaired can use both tactile and auditive information to detect danger areas

NEGATIVE ASPECTS

- the corners of the tiles may turn up, causing an uneven surface
- may get slippery

REMARKS:

Ref. Pages:

Han 1, 2, 3, 5

Literature:

DOT Pedestrian Guidelines; Parking Standards; UTG1; SARTSM

DESCRIPTION

Parking bays for the physically disabled

MEASURE PAGE

SM8

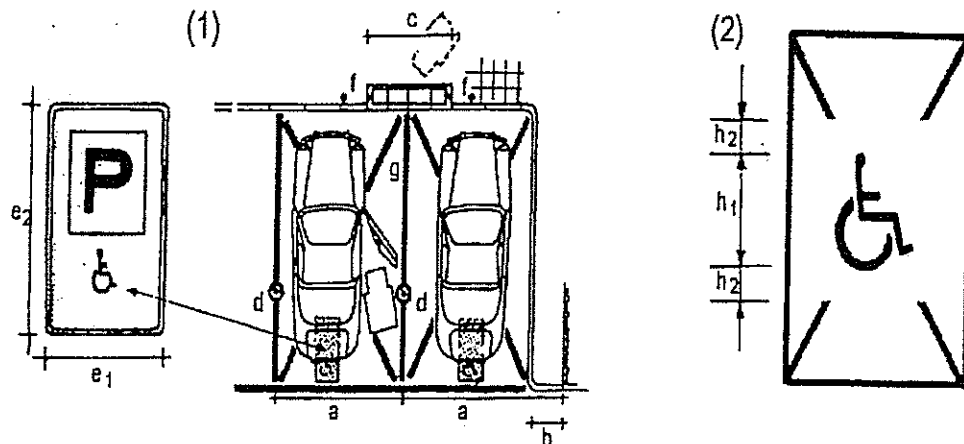
CONDITIONS FOR APPLICATION

- [specially adapted parking space for the physically disabled]

DIMENSIONS

- (for a, b and c see RU1-3)
- d = posts, height circa 0.85 m in contrasting colour
- e<sub>1</sub> = 0.6 m
- e<sub>2</sub> = 0.9 m
- h<sub>1</sub> = 1 - 1.5 m
- h<sub>2</sub> = 0.5 m

IMPLEMENTATION

- road traffic sign 54b or 54c (f)
- signs painted on road surface
- where necessary, use can be made of pictogram (1) or (2) as attention getters, or the parking bay can be raised and paved in a contrasting colour
- where several bays are positioned next to each other, make use of post (d) to prevent illegal/unauthorised parking
- pictogram (1): blue background with white markings and black P on white background
- pictogram (2): white (may use yellow, although this is not recommended)

ASSISTING MEASURES

- placing of parking bays for vehicles transporting persons(s) with a physical disability:
  - parallel parking: see RU1
  - right-angle parking: see RU2
  - diagonal parking: see RU3
- neutralization of different levels and kerb ramp construction: see TM58-60
- kerb cut/exit ramp: see SM5

POSITIVE ASPECTSNEGATIVE ASPECTS

- wide bays may encourage illegal use
- poor utilization may encourage illegal use
- high maintenance

REMARKS:

Ref. Pages:  
Literature:

DOT P/edestrian Guidelines; Parking Standards; UTG1; SARTSM



DESCRIPTIONMEASURE PAGE

Contrasting paving at entrance to 30 km/h-zone

SM9

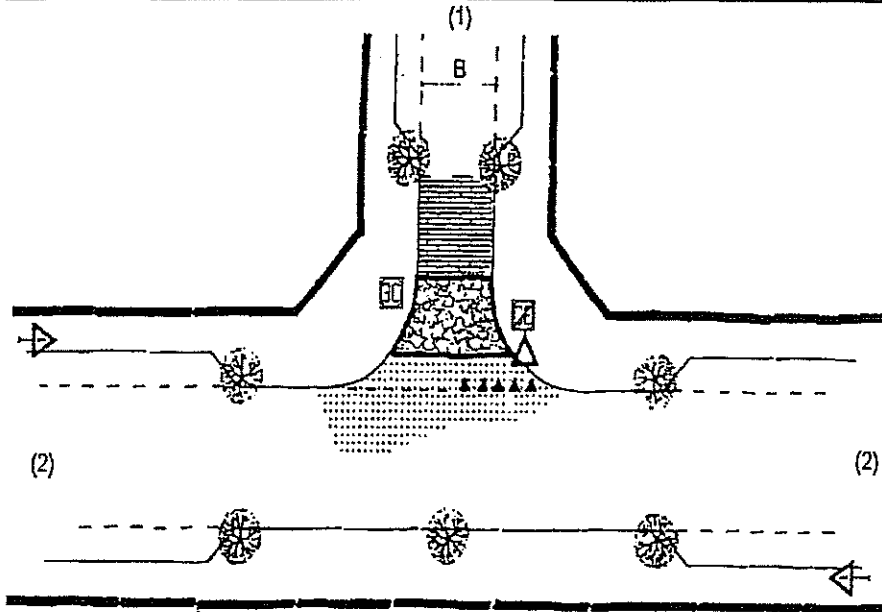
CONDITIONS FOR APPLICATIONDIMENSIONS

- $B < 5$  (6) m
- peak hour volumes  $< 200$  vph on (1)
- $< 700$  vph on (2)
- not on bus and/or supply/provisioning routes
- only at T-junctions

IMPLEMENTATIONASSISTING MEASURES

- paving preferably in the same or nearly the same colour and material as the sidewalk. No exit.
- paving should not be uneven, as it will be crossed by pedestrians
- lengthwise construction cover
- should not be possible to mistake (1) for the entrance to private premises
- road signs 30 km/h-zone
- (2) should be main road

POSITIVE ASPECTSNEGATIVE ASPECTS

- attention getter
- distinct/unmistakable transition to 30 km/h-zone

- possible increase in speed on (2) with introduction of local priority area
- may be mistaken for exit
- dissimilar/unequal friction coefficient

REMARKS:Ref. Pages:  
Literature:SR9  
DOT Pedestrian Guidelines; Parking Standards; UTG1; SARTSM

**DESCRIPTION****MEASURE PAGE**

Guidance lines

SM10

A guidance line is a guiding line formed by artificial means on or in the road surface. It can be easily recognized by form, texture and placement in contrast to the surrounding pavement

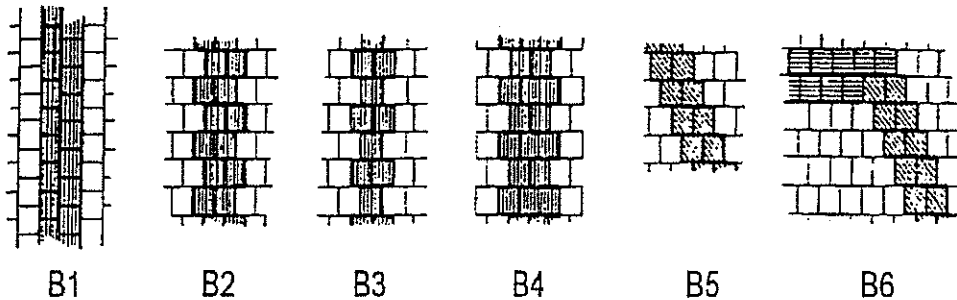
**CONDITIONS FOR APPLICATION**

- on pedestrian routes, to help the visually impaired where there are no natural guidance signs
- at pedestrian crossings: see SM11

**IMPLEMENTATION**

- keep design simple, outlines logical and comprehensible (avoid obstacles, provide enough space)
- guidance tiles (see SM6) in pattern, ribbed in direction of movement
- change of direction 45°:
- smaller changes in direction are indicated by slanting tiles
- on bitumen surfaces: use weatherproof strips of material for skid-free surfaces
- for the partially sighted, carry out in contrasting colour (of little or no use after dark or in poor weather)

**POSITIVE ASPECTS**

- promotes safe and independent participation in traffic situation by the physically disabled

**DIMENSIONS**

- depending on chosen pattern, preferably B1 or B4

**ASSISTING MEASURES**

- guideline: see RU11
- obstacles: see RU12, RU13
- marking of obstacles: see SM13
- paving: see SM4
- danger signs: see SM12

**NEGATIVE ASPECTS**

- expensive (initial outlay and maintenance)
- difficult to implement
- may be inconvenient to other road users
- may cause conflict on aesthetic grounds

**REMARKS:**

Ref. Pages:  
Literature:

Han 1, 3  
DOT Pedestrian Guidelines; Parking Standards; UTG1; SARTSM

DESCRIPTIONMEASURE PAGE

Guidance line at pedestrian crossing

SM11

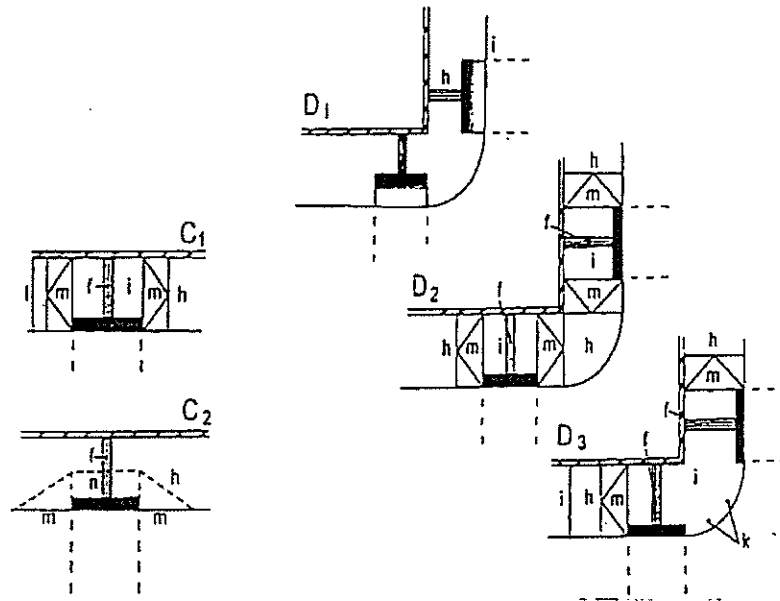
CONDITIONS FOR APPLICATION

- at pedestrian crossings:
  - $C_1$  on sidewalks  $\leq 1.5$  m excl. kerb
  - $C_2$  on sidewalks  $> 1.5$  m excl. kerb
  - $D_1$  at ramps
  - $D_2$  (or  $C_2$ ) at corners  $R > 6$  m
  - $D_3$  at corners  $R \leq 6$  m

DIMENSIONS

- $f$  = guidance line
- level  $l = h - 10$  cm
- $k$  = posts: height 1.20 m in contrasting colour
- $l \geq 1.2$  (0.9) m excl. kerb
- $m = 1:20$
- $n = 1:12$  (1:9)

IMPLEMENTATION

- place in such a way that the distance to be crossed is kept as short as possible
- guidance tiles as in SM10 (use B1-4) square to the roadway, ribbed in direction of movement
- for the partially sighted, carry out in contrasting colour (of little or no use after dark or in poor weather)

ASSISTING MEASURES

- paving: see SM4
- danger signs (use black): see SM12
- overcoming of difference in levels and ramp construction: see TM58-60
- kerb-cut ramp: see SM5

POSITIVE ASPECTS

- promotes safe and independent participation in traffic situation by the physically disabled

NEGATIVE ASPECTS

- expensive (initial outlay and maintenance)
- difficult to implement
- may be inconvenient to other road users
- may cause conflict on aesthetic grounds

REMARKS:

Ref. Pages: Han 2, 5  
 Literature: DOT Pedestrian Guidelines; Parking Standards; UTG1; SARTSM

DESCRIPTIONMEASURE PAGE

Warning markings

SM12

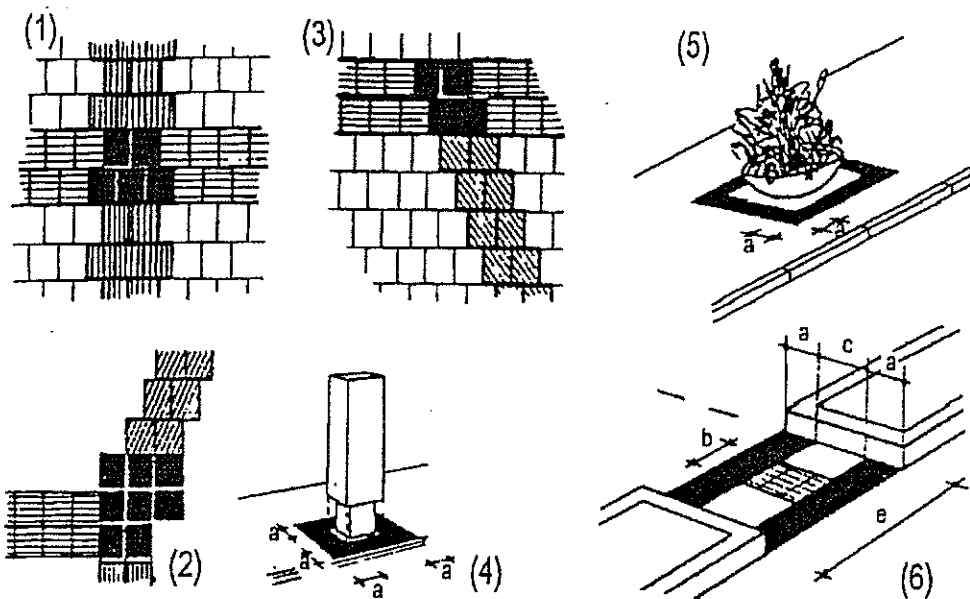
CONDITIONS FOR APPLICATION

- on sidewalks, footpaths and in pedestrian only areas, to assist the visually impaired
- (1) - (3) on junction of intersection of guidance lines
- (4)(5) around difficult to detect obstacles

DIMENSIONS

- $a = 0.6 \text{ m}$
- $b = 0.6 \text{ guidance tiles; if } c \leq 0.9 \text{ m, a sunken short cut paved in warning tiles}$
- $e \geq 1.5 \text{ m; but } \geq 1.8 \text{ m if to be used by wheelchairs}$

IMPLEMENTATION

- warning tiles: see SM7
- place warning tiles outside the vertical projection of the obstacle

ASSISTING MEASURES

- placing of guidance lines: see SM10, SM11
- placing of obstacles: see RU12
- design of obstacles: see RU13
- guiding line: see RU11

POSITIVE ASPECTS

- promotes safe and independent participation in traffic situation by the physically disabled

NEGATIVE ASPECTS

- (4) more expensive than RU13 (3)

REMARKS:Ref. Pages:  
LiteratureHan 1, 2, 3, 5, 8  
DOT Pedestrian Guidelines; Parking Standards; UTG1; SARTSM

DESCRIPTION

Marking of obstacles by visual means

MEASURE PAGE

SM13

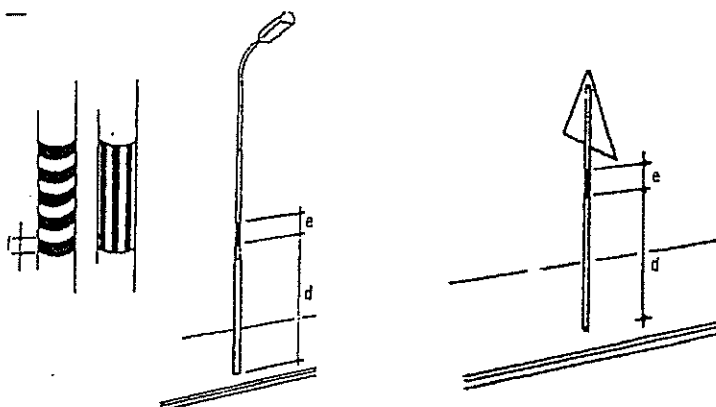
CONDITIONS FOR APPLICATION

- on pedestrian routes and footpaths, to assist the partially sighted

DIMENSIONS

- $d = 1.5 \text{ m}$
- $e \geq 0.3 \text{ m}$
- $f \geq 0.04 \text{ m}$

IMPLEMENTATION

- permanent obstacles should be marked at eye-level with contrasting colours (striking colours are signal yellow, white, diagonal stripes in black/white, vertical stripes in red/white or horizontal stripes in signal red and orange)
- shorter guiding posts and no-parking post painted a contrasting colour
- choice of colours:
  - white: attention - getter
  - yellow (black): use on obstacles as stairs, traffic posts, lamps
  - orange: banisters
- use clear contrasting colours
- use weatherproof paints and colours

ASSISTING MEASURESPOSITIVE ASPECTS

- beneficial not only to the partially sighted by making obstacles more visible, but also to children and the aged
- uniform use of colours increases efficiency
- promotes safe and independent participation in traffic situation, especially by the visually impaired
- inexpensive to install if standardized

NEGATIVE ASPECTS

- too many contrasting colours may be offensive
- expensive in existing situations where other finishes have to be replaced

REMARKS:

Ref. Pages:  
Literature:

Table E.2; Han 1, 3

DOT Pedestrian Guidelines; Parking Standards; UTG1; SARTSM

DESCRIPTION

Marking of obstacles by tactile means

MEASURE PAGE

SM14

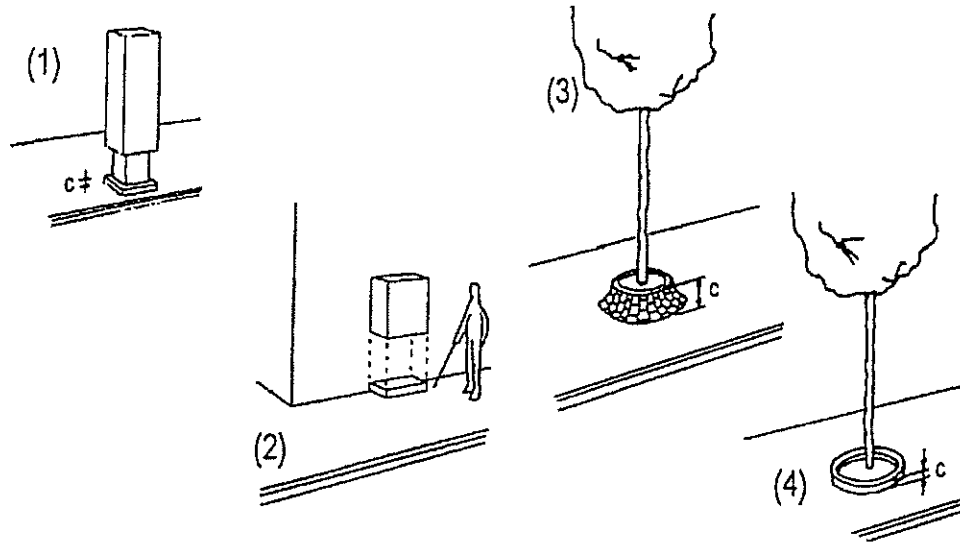
CONDITIONS FOR APPLICATION

- on pedestrian routes and footpaths, to assist the visually impaired

DIMENSIONS

- $c \geq 0.10 \text{ m}$

IMPLEMENTATION

- where obstacles do not extend down to ground level, make use of a platform of the same shape on ground level, otherwise, use warning/danger signs
- bow-shaped plant containers and bicycle shelters should be placed on a higher level, if not, use warning/danger signs
- around trees:
  - sloped paving around tree, preferably in natural stone
  - raised kerb around tree
- for the partially sighted, mark raised kerb with contrasting colour (yellow)

ASSISTING MEASURES

- placing of obstacles: see RU12
- design of obstacles: see RU13
- visual means: see SM13

POSITIVE ASPECTS

- beneficial not only to the visually impaired by making obstacles easy to notice, but also to children and the aged
- promotes safe and independent participation in traffic situation by the physically disabled, especially the visually impaired

NEGATIVE ASPECTSREMARKS:

Ref. Pages:  
Literature:

Table E.2, Han 1  
DOT Pedestrian Guidelines; Parking Standards; UTG1; SARTSM

DESCRIPTION

Signpost for the physically disabled

MEASURE PAGE

SM15

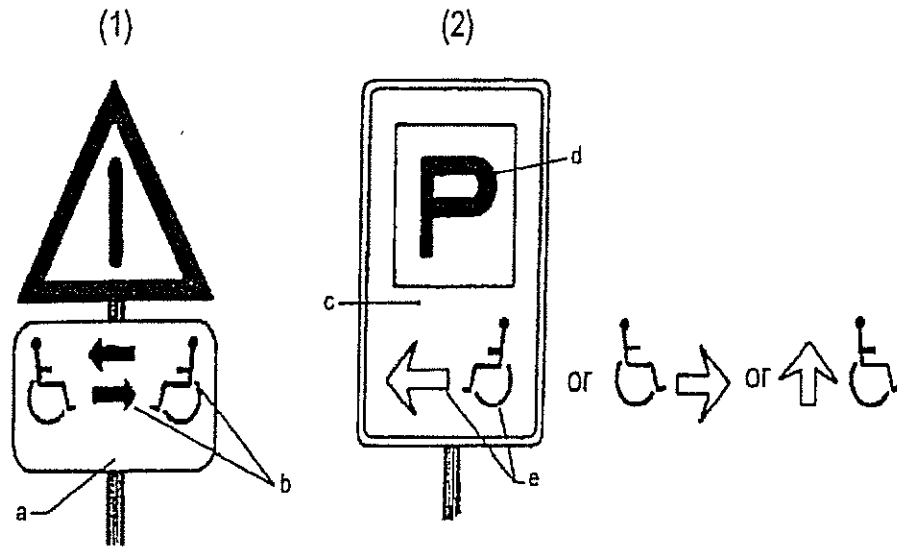
CONDITIONS FOR APPLICATION

- (1) on pedestrian crossings used on a regular basis by physically disabled persons, near hospitals, rehabilitation centres or housing for the disabled
- (2) refers to parking bays(s) for the vehicles of physically disabled persons near public buildings and destinations accessible to the physically disabled, such as hospitals and shopping centres

DIMENSIONS

- (1) traffic sign 50 x 20 or 70 x 25 cm
- (2) additional sign 114 (adopted)

IMPLEMENTATION

- a: white background
- b: black arrow and symbol
- c: blue background with white frame
- d: black p on white background
- e: white arrow and symbol

ASSISTING MEASURES

- marking of obstacles: see SM13

POSITIVE ASPECTS

- promotes safe and independent participation in traffic situation by the physically disabled

NEGATIVE ASPECTSREMARKS:

Ref. Pages: Han 7, 8  
Literature: DOT Pedestrian Guidelines; Parking Standards; UTG1; SARTSM

DESCRIPTIONMEASURE PAGE

Signposts for pedestrians, and small sign plates

SM16

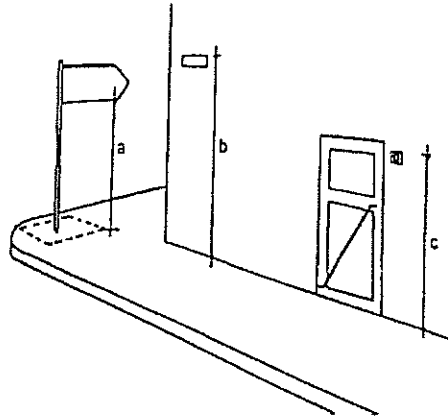
CONDITIONS FOR APPLICATION

- road sign posts and route information for pedestrians

DIMENSIONS

- $a \geq 2.2$  m (easily passable)
- $b \leq 2.5$  m (attachment height area information and street name plates)
- $c \leq 2$  m (attachment height house numbers)

IMPLEMENTATION

- should be clearly visible and legible from vehicle and wheelchair, especially for the partially sighted
- area maps clearly legible (non-reflective glass covering sufficient illumination) and within easy reach
- for the blind, relief maps and written information provided in braille (combine with auxiliary element such as handrails)
- for the partially sighted, use large print (possibly in relief) and contrasting colours (black print on yellow background)
- provide night-time illumination
- guiding posts in contrasting colours

ASSISTING MEASURES

- should be visible from wheelchairs
- maps and information panels: see SM17
- marking of obstacles: see SM13

POSITIVE ASPECTS

- promotes safe and independent participation in traffic situation by the physically disabled
- better orientation possibilities for all users

NEGATIVE ASPECTSREMARKS:Ref. Pages:  
LiteratureTable E.2; Han 3, 4, 6, 7  
DOT Pedestrian Guidelines; Parking Standards; UTG1; SARTSM



**DESCRIPTION**

Maps and information panels

**MEASURE PAGE**

SM17

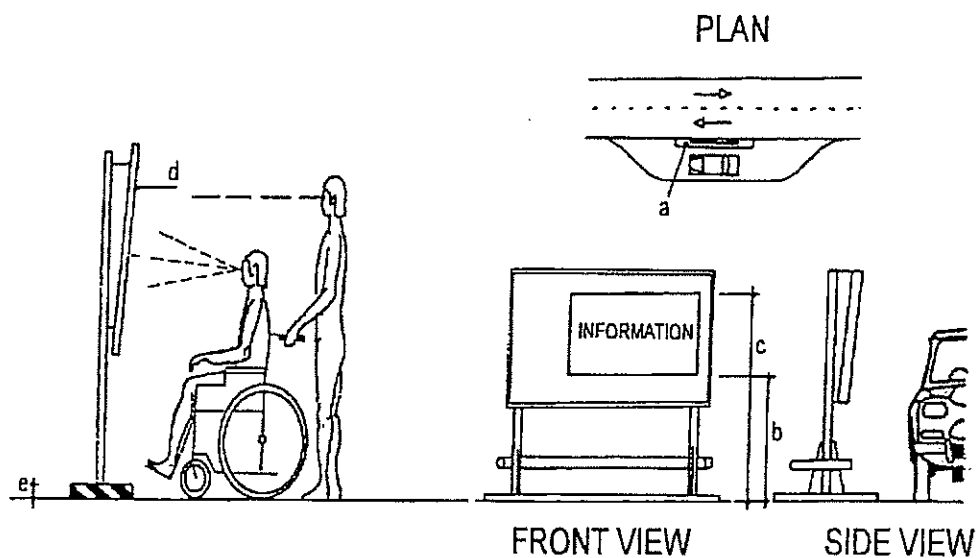
**CONDITIONS FOR APPLICATION**

- city maps and information signs next to roads
- information panels on pedestrian routes, in shopping centres and in residential areas

**DIMENSIONS**

- $b = 0.9$  m
- $c = 1.7$  m
- $d = 10:1$
- $e = 0.1$  m

**IMPLEMENTATION**

- should be clearly visible and legible from vehicle or wheelchair and when standing
- combined with warning tiles or raised pavement
- position information panels on roads on the driver's side if possible
- mark side of raised pavement with contrasting colour (yellow)

**ASSISTING MEASURES**

- eye height and visible area
- choice of print and colour: see SM16
- marking of obstacles: see SM13
- placing of obstacles: see RU12
- safety measures at obstacles: see SM12

**POSITIVE ASPECTS**

- driver does not have to leave vehicle if positioned on the median (important for the physically disabled)
- information accessible to all motorists
- promotes safe and independent participation in traffic situation by the physically disabled

**NEGATIVE ASPECTS**

- needs extra space on the side strip or median

**REMARKS:**

Ref. Pages:  
Literature:

Table E.2, Han 3, 4, 6, 7, 8  
DOT Pedestrian Guidelines; Parking Standards; UTG1; SARTSM

DESCRIPTION

Narrowing of sidewalk

MEASURE PAGE

SM18

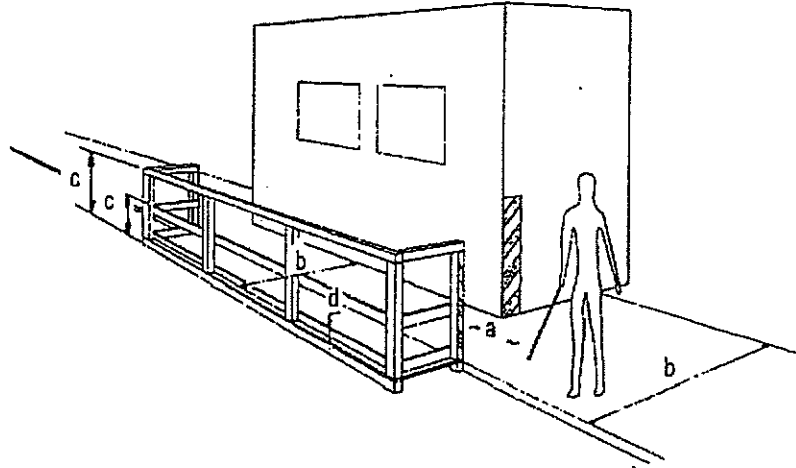
CONDITIONS FOR APPLICATION

- on and next to sidewalks where movement of pedestrians is restricted

DIMENSIONS

- $b \geq 1.2$  m
- $a = 1.5$  m (enough space for a wheelchair)
- $c = 1$  m
- $c' = 0.5$  m
- $d = 0.1$  m

IMPLEMENTATION

- wooden floor should be covered with non-skid, non-slip material. Erect barriers on the side
- floor and sidewalk on same level
- where the pavement slopes, gates and side barriers may be sufficient
- enclose ladders with barriers. Ensure open passage

ASSISTING MEASURES

- warning gates
- illumination

POSITIVE ASPECTS

- improved safety

NEGATIVE ASPECTS

- may be in people's way

REMARKS:

Ref. Pages:  
Literature:

Han 1, 3, 6, 9  
DOT Pedestrian Guidelines; Parking Standards; UTG1; SARTSM

**APPENDIX F- CALCULATION OF EAN****DETERMINATION OF THE EQUIVALENT ACCIDENT RATE PER 1 MILLION VEHICLE KILOMETRES TRAVELLED**

The equivalent accident rate takes into account accident severity when investigating a change to the speed limit along a road section with a poor accident record is investigated.

- 1 Determine the vehicle kilometres travelled on the relevant road section.** (A sample of at least 5 million vehicle kilometres travelled is required)

**Example**

Average daily traffic volume x length of road section x number of days over which accident data apply.

e.g. 21 600 vehicles x 1,7 km x 356 days  
= 13,4 million vehicle kilometres.

- 2a) Determine the number of accidents by severity on the road section for the corresponding period, multiply each severity type with the recommended weighted factor and sum these.**

**Example**

<b><u>Severity</u></b>	<b><u>No. of Accidents</u></b>		<b><u>Weighting<sup>x</sup></u></b>		<b><u>Equivalent no of accidents</u></b>
Fatal	7	x	12	=	84
Injury	35	x	3	=	105
Damage only	179	x	1	=	179
					<b>Total 368</b>

<sup>x</sup>Weighting recommended in manual K21

- 3 Calculate the equivalent accident rate per million vehicle kilometres travelled**

**Example**

Equivalent accidents per million vehicle km. =  $\frac{\text{Total equivalent no. of accidents}}{\text{Millions of vehicle km travelled}}$   
=  $\frac{368}{13,4}$   
= 27,6 equivalent no. of accidents/million vehicle kilometres